

An aerial architectural rendering of a city center, likely York Central, showing a river on the left, a central circular plaza, and surrounding urban development. The rendering is in a light gray tone, overlaid on a darker gray background.

# YORK CENTRAL DESIGN GUIDE

YCL-ALM-ZZ-XX-RP-AX-0003

July 2018





# THE VISION FOR YORK CENTRAL

York Central provides a transformational opportunity to realise the significant ambition for economic and housing growth in York. York Central's excellent location in the heart of the city and next to York Railway Station will deliver a well-connected and sustainable neighbourhood accessible to all. Drawing on its railway heritage, it will be a place full of life and vitality, delivering a vibrant new part of the city, providing homes and jobs for the people of York.

The buildings and spaces at York Central will be high quality and complement the historic setting and fantastic connections to the city centre and railway network. Homes will range from first homes to those for families and for older people, suitable for all stages of life and affordable to all.

Businesses will benefit from a range of innovative and flexible workspaces for growing local companies and start-ups, as well as providing the capacity and quality of space to make York a landmark business destination and attract national and international businesses around York's growing industry strengths, such as in rail, insurance and digital. York Central will enable business growth and attract inward investment to create good quality jobs for the people of York. It will be a hub and catalyst for creativity and innovation.

The National Railway Museum will be the cultural heart of York Central. It has an exciting and ambitious emerging masterplan to tell the epic stories of the impact of railways on the world. The Museum will contribute to York's tourist industry with significant growth in visitor numbers discovering its world-class collection with a new Central Gallery showcasing the latest innovations from the modern railway industry.

A lively public square will be at the heart of the new community and will create a bold sense of arrival for residents, visitors and workers alike. Extensive public spaces and a wonderful public park for formal and informal cultural events will be available for community interaction, play and recreation.

High-quality digital and physical infrastructure will be provided from the outset, encouraging low carbon living and providing the flexibility needed for sustainable energy solutions fit for the 21st century, building in low running costs through high efficiency standards.

York Central will prioritise pedestrians and cyclists with excellent public transport, creating convenient and safe pedestrian and cycle access through the site to the city centre, railway station and surrounding communities and linking into city-wide footpaths and cycle ways, to enjoy the wider York environment.

# CONTENTS

	<b>THE VISION FOR YORK CENTRAL .....</b>	<b>4</b>			
<b>1</b>	<b>INTRODUCTION .....</b>	<b>2</b>		<b>3</b>	<b>PUBLIC OPEN SPACE .....</b>
	1.1 Purpose of the Design Guide	4		3.1 Landscape Strategy	46
	1.2 Parameter Plans and Development Specification	4		3.2 Ecology strategy	48
	1.3 Scope of the Design Guide	5		3.3 Sustainable Urban Drainage strategy	50
	1.4 How to use the Design Guide	6		3.4 Public Art Strategy	54
	1.5 Compliance with the Design Guide	6		3.5 Recreation and Play Strategy	56
	1.6 Monitoring and Review	8		3.6 Central Park	58
	1.7 Cumulative Development Plan	8		3.7 New Square	64
	1.8 Illustrative Masterplan	9		3.8 Station Quarter	70
	1.9 Principles of the Masterplan	10		3.9 Foundry Quarter	72
	1.10 Nomenclature	12		3.10 Site Perimeter	74
	1.11 Structure of the Design Guide	14		<b>4</b>	<b>STREETS .....</b>
<b>2</b>	<b>HEIGHTS, MASSING AND LEVELS .....</b>	<b>19</b>		4.1 Street Hierarchy	78
	2.1 Introduction	20		4.2 Street Adoption	79
	2.2 Maximum Developable Extents	22		4.3 Pedestrian Connectivity	80
	2.3 Visual Permeability	23		4.4 Cyclist Connectivity	82
	2.4 Townscape Considerations	24		4.5 Primary Streets	86
	2.5 National Railway Museum: Development Zone G	26		4.6 Secondary Streets	102
	2.6 Station Quarter: Development Zones B, C, D & F	28		4.7 Tertiary Streets	112
	2.7 York Yard South: Development Zones M, J & E	34		4.8 Foot Streets	120
	2.8 Foundry Quarter: Development Zones H, K, L, N, P	38		4.9 Play Streets	126
				4.10 Snickets	130
				4.11 Road Crossings	132
				4.12 Road and Railway Crossing Points	133
				4.13 Street Tree Framework	134
				4.14 Material Palette	135
				4.15 Street Furniture	139
				4.16 Lighting	140
				4.17 Wayfinding	142

<b>5</b>	<b>HERITAGE ASSETS.....</b>	<b>145</b>	<b>7</b>	<b>APPEARANCE BY CHARACTER AREA... 199</b>
5.1	Introduction	146	7.1	Introduction
5.2	General Guidance	148	7.2	Station Quarter
5.3	National Railway Museum	152	7.3	York Yard South
5.4	Foundry Quarter	154	7.4	Foundry Quarter
5.5	Station Quarter	160	<b>8</b>	<b>BUILDING TYPOLOGIES .....241</b>
5.6	Chancery Rise	163	8.1	Introduction
<b>6</b>	<b>APPEARANCE SITE WIDE.....</b>	<b>165</b>	8.2	Mews
6.1	Introduction	166	8.3	Terraces
6.2	“Uniform Irregularity”	168	8.4	Town Houses
6.3	Grain	170	8.5	Mansion Blocks
6.4	Background and Foreground Buildings	171	8.6	Workspace
6.5	Roofs Site Wide	172	8.7	Office Buildings
6.6	Roof Edges	176	8.8	Mixed-use Buildings
6.7	Dormer Windows	180	8.9	Pavilion Buildings
6.8	Solar panels	181	8.10	Hotel Buildings
6.9	Wall Materials Site Wide	182	8.11	Multi Storey Car Park Buildings
6.10	Windows	186	<b>9</b>	<b>SUSTAINABILITY .....265</b>
6.11	Bay Windows	187	9.1	Sustainable Framework
6.12	Shopfronts	189	9.2	Climate Adaptation
6.13	Integrating public infrastructure and building services	192	9.3	Energy and Carbon
6.14	Plot Boundaries and Fences	194	9.4	Health and Well being
6.15	Site Perimeter Fences	196	9.5	Materials and Waste
6.16	Parking and Cycle Storage	197	<b>10</b>	<b>GLOSSARY.....272</b>
			<b>11</b>	<b>IMAGE CREDITS.....282</b>

# 1 INTRODUCTION

The redevelopment of York Central is being brought forward by the York Central Partnership, a collaboration between the City of York Council, Network Rail, the National Railway Museum and Homes England. The applicant is Network Rail and Homes England.

Located on one of the largest brownfield sites in the UK, York Central includes opportunities for a new office quarter, new residential communities, an expanded and enhanced Railway Museum, improved access to the railway station and a network of vibrant public spaces with routes linking York Central to surrounding neighbourhoods and the city centre.

The York Central Design Guide, in combination with the York Central Parameter Plans and Development Specification, form a set of control documents through which the Local Authority (City of York Council) will determine future Reserved Matters Applications for the site.

This document is supported by the Illustrative Scheme; Design and Access Statement; and Environmental Statement.

The Design Guide is supplementary and additional to all relevant statutory guidance, Building Standards and Approved Documents. Where any conflict arises the



**Control Documents**

Planning Permission  
and Conditions

Parameter  
Plans

Development  
Specification

Design  
Guide

**Illustrative material &  
supportive assessments**

Design and  
Access Statement  
Illustrative Masterplan  
Illustrative Plans  
Transport Assessment  
Framework Travel Plan  
Environmental Statement 1-4  
Energy Statement  
Sustainability Statement  
Town Centre Uses Statement  
Flood Risk Assessment  
Drainage Assessment  
Foul Sewerage  
& Utilities Statement  
Tree Survey  
Statement of Community  
Involvement

Section 106 Agreement

Planning Consent and Conditions

## 1.1 PURPOSE OF THE DESIGN GUIDE

The purpose of the Design Guide is to establish a robust framework for the Application Site that encourages quality of design which will be reflected in future Reserved Matters Applications (RMAs). The Design Guide is intended to provide guidance to developers, architects and other designers in developing detail schemes for York Central.

These guidelines have been developed following a comprehensive process of community engagement and consultation with the CYC, Historic England and other stake holders.

Included in the document are diagrams and reference images intended to help demonstrate the design intent discussed. All such references are provided for illustrative purposes only.

The document includes mandatory codes which are set out in bold and shall and must be adhered to for RMAs. It also includes advisory guidelines which are supporting and aspirational. These guidelines should be considered as part of the application process and should be adhered to where practicable.

These codes and guidelines relate to key aspects of the site and context; Townscape considerations; Character areas; Streets; Building typologies; and Principles of place making. Alongside other aspects of the planning and design process, these will help inform the overall quality and character of the future development of the York Central Site.

## 1.2 PARAMETER PLANS AND DEVELOPMENT SPECIFICATION

The Design Guide must be read in conjunction with the York Central Development Specification, Parameter Plans and Red Line Plan.

The Parameter Plans are as follows:

YC - PP 001 Demolition

YC - PP 002 Demolition Enlarged Extract

YC - PP 003 New Railway Additions

YC - PP 004 Development Zones - Above Ground

YC - PP 005 Access and Circulation Routes

YC - PP 006 Development Zones Ground Level Uses

YC - PP 007 Development Zones Upper Floor Uses

YC - PP 008 Development Zones and Uses below Ground

YC - PP 009 Development Zones and Maximum Heights

YC - PP 010 Proposed Site Levels

YC - PP 011 Open Space Areas

YC - RL 001 Planning Application Boundary

In addition to these drawings the following Illustrative Plans have been generated for information purposes.

YC - IL 100 Illustrative Masterplan

YC - IP 001 Existing Structures

YC - IP 002 Retained Buildings

YC - IP 003 Existing Site Levels

### 1.3 SCOPE OF THE DESIGN GUIDE

The design guide provides information and guidance on the Illustrative Masterplan at all scales from site wide strategy and considerations; the masterplan framework - streets and public realm; building typologies and architectural language and appearance.

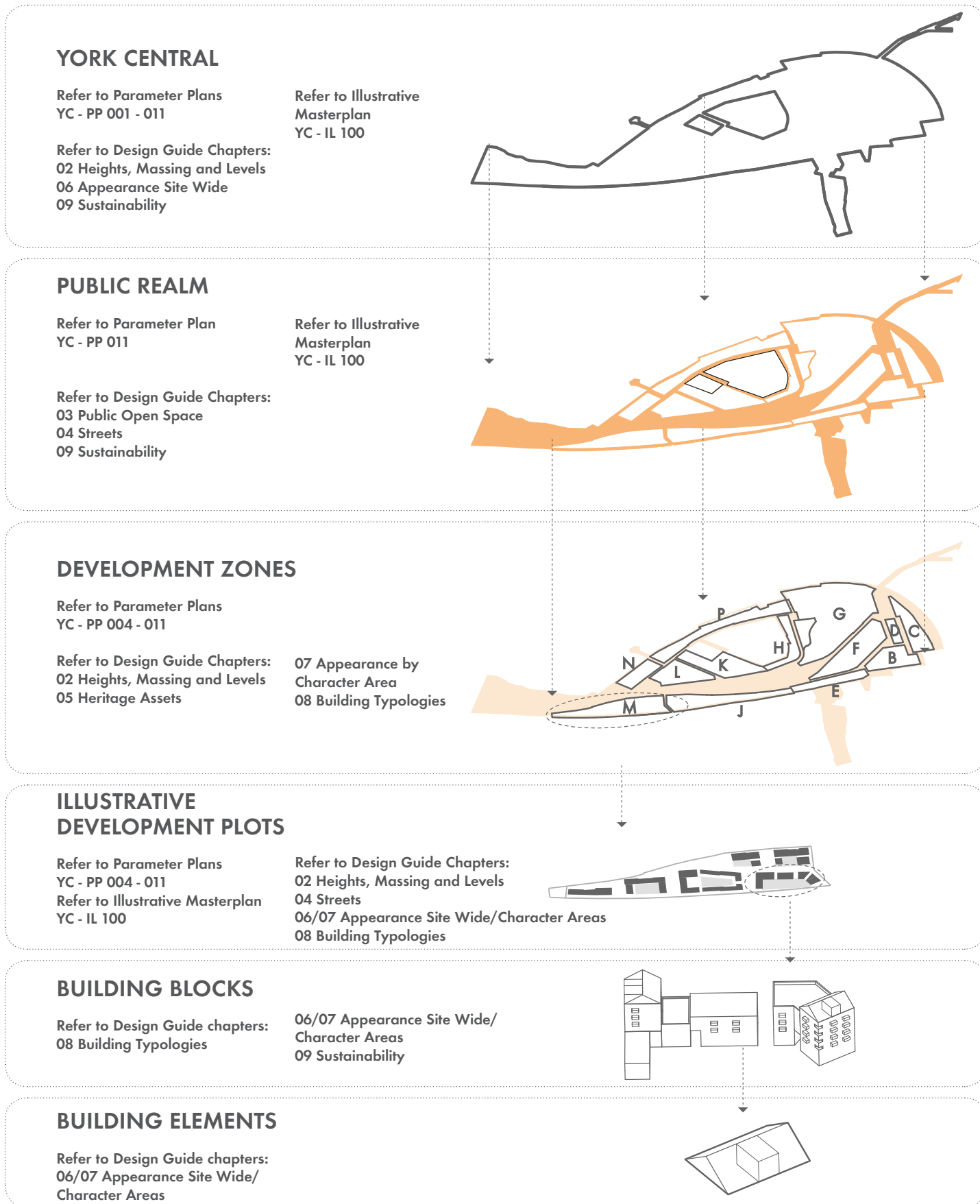

## 1.4 HOW TO USE THE DESIGN GUIDE

The Design Guide should be read in conjunction with the Parameter Plans, Development Specification, Planning Consent and Conditions and Drawings for Information. These documents relate, primarily, to quantitative, volumetric and spatial parameters, but the Design Guide aims to communicate the different qualities and character of the scheme in the 'spirit' and underlying 'design intent' of the Illustrative Masterplan.

Further detail on the design principles, space making proposals, heritage research and design methodology, including details explaining the process of community engagement can be found in the Design and Access Statement.

## 1.5 COMPLIANCE WITH THE DESIGN GUIDE

### **All subsequent applications on the York Central site must demonstrate compliance with the Design Guide.**

This should be demonstrated through a Design Compliance Statement.

The Design Compliance Statement must refer to the relevant documents in the York Central Outline Planning Permission e.g. Parameter Plans, Development Specification and Design Guide.

It must demonstrate and explain how the scheme fits within the Parameter Plans; the quantum of development the application represents in terms of use; how the development will impact on the developable quantum of any future phases of the Development zone(s); and demonstrate the impact on the cumulative development of the wider York Central Site. It must show how the proposal responds positively to the Vision for the site; how the scheme addresses the mandatory codes of the Design guide. It must provide a demonstration of the underlying design intent and aims captured in the Design Guide.

The Design Compliance Statement should reflect the breadth of topics covered by the Design Guide and should therefore address, as a minimum, the following:

- the vision for the site
- site context
- quantum of development
- aspects of the development relating to the public realm
- aspects of the development relating to the Character Areas
- sustainability

Departures from the Design Guide will only be acceptable if there is a clear rationale for deviation which can clearly demonstrate the place making benefits, or respond appropriately to changing legislation, circumstances and technological advancement. In these instances, the justification for the deviation from the Design Guide shall be given reasonable consideration by the CYC. Any subsequent revisions to the approved Design Guide shall be subject to the written approval of the CYC.

POTENTIAL PROCESS OF APPROVAL: RESERVED MATTERS APPLICATION

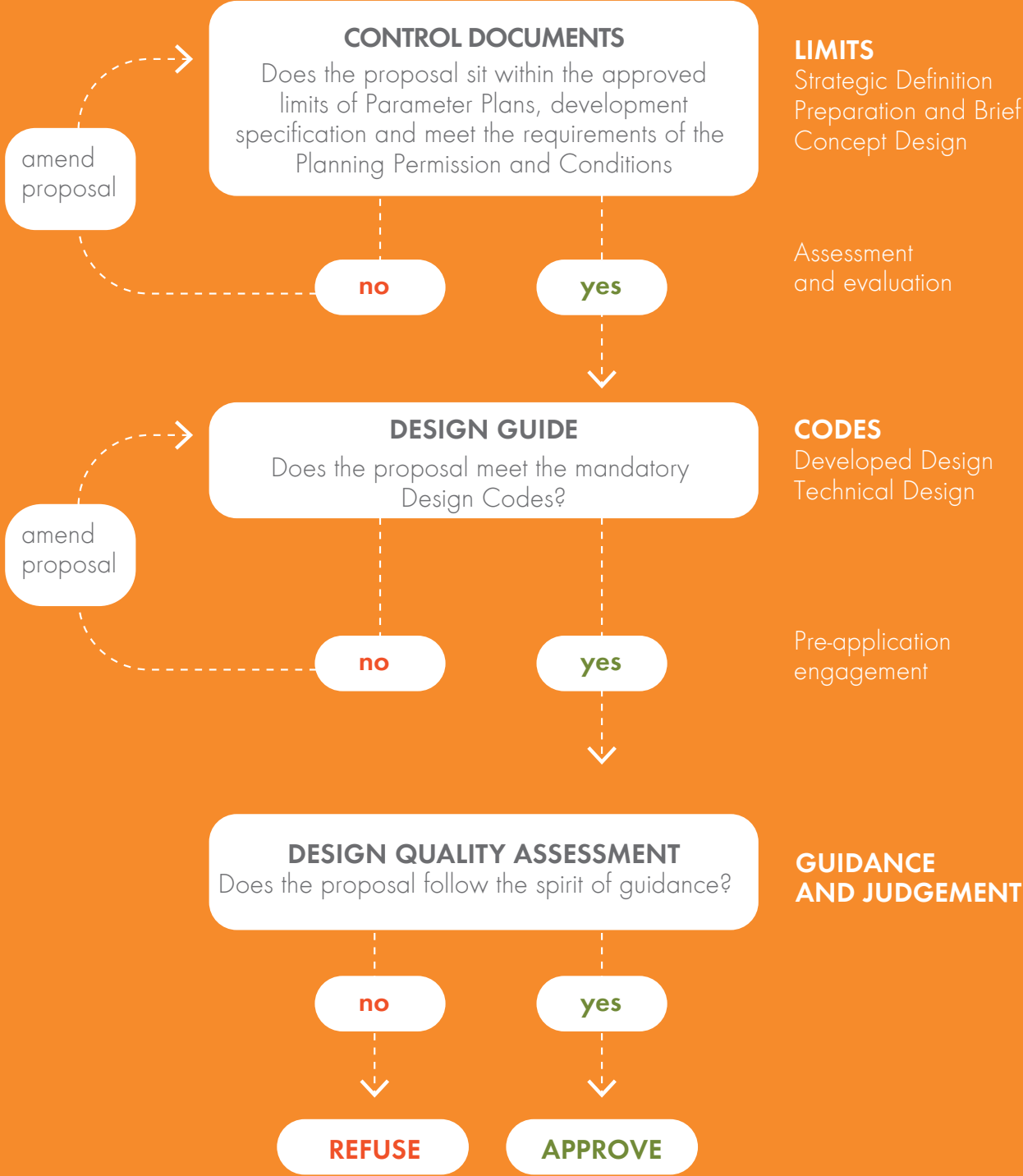

## 1.6 MONITORING AND REVIEW

From time to time, there may be aspects of the Design Guide that require modification to reflect design issues that become apparent as circumstances change. In such circumstances, it may be appropriate or necessary for the land owner, developer, applicant and/or CYC to request a review of the Design Guide.

When such a request is made, the matters to be reviewed must be specified together with an explanation of the reasoning for the request and a timetable for this review. The review process is intended to focus on matters of detail and not matters of principle established within the Design Guide.

Any changes to the Design Guide must be agreed with the CYC.

## 1.7 CUMULATIVE DEVELOPMENT PLAN

The development of the York Central Site will take place over many years. In order to track its evolution in relation to the Parameter Plans and the Design Guide. A 'Cumulative Development Plan' will be maintained and be updated at regular intervals.

This process will enable the developer and CYC to assess any individual scheme, brought forward by RMA, against the Outline Permission.

This shall be supported by applicants of any RMAs who shall provide any material required in order to update and keep this Plan.

## 1.8 ILLUSTRATIVE MASTERPLAN

The Illustrative Masterplan is an informative part of the York Central Outline Planning Application. The Illustrative Masterplan has evolved from consideration of townscape, heritage and socio-economic considerations. It has been used to :

- Test and refine the Parameters Plans which form the basis of the Development Specifications and Design Guide.
- Explore the spaces, massing, mix and grain of the development emerging through the masterplan as it has evolved.
- Provided essential testing criteria for Townscape Views, massing and height constraints.
- Created a framework for the development of the site in terms of a mix and quantum of uses; building typologies; streets; and open spaces.

- Generated images for both the Design Guide and the Design and Access Statement
- Helped to inform an indicative phasing plan.

Alongside the Design Guide, Development Specification and Parameter Plans, the Illustrative Masterplan can help to consider and assess any RMAs (Reserved Matters Application).



Fig.01 Illustrative Masterplan for York Central

## 1.9 PRINCIPLES OF THE MASTERPLAN

Over the course of the project and continued public engagement, some key themes have emerged. These have helped to shape the Illustrative Masterplan, both in terms of townscape and character, building uses, housing and workplace requirements that will be key to delivering a thriving and vibrant addition to the city of York.

The principles of the Illustrative Masterplan reflect the broad interests and concerns that have emerged from discussions with the LPA, Statutory Consultees, and engagement process.

These principles should be the starting point of any RMA and should inform the design response to the site.

The masterplan principles are as follows:



Fig.02 Drawing



REFLECT YORK'S TOWNSCAPE, ENHANCING OR BETTER REVEALING THE SETTING OF HERITAGE ASSETS, AND TELL THE RAILWAY STORY.

ALLOW UNIQUE CHARACTER AND HISTORY TO CREATE AN INTEGRATED AND COHESIVE PART OF CITY.

NEW AND EXISTING CONNECTIONS THAT PROVIDE RESILIENT, CONVENIENT, INCLUSIVE AND PERMEABLE ROUTES.

CREATE RICH AND VARIED CHARACTER AREAS. INCORPORATE HOMES, WORK, RETAIL, COMMUNITY, MUSEUM AND LEISURE USES THAT ACTIVATE FRONTAGES AND ANIMATE PUBLIC SPACES.

ESTABLISH THE MASTERPLAN AS AN EXTENSION OF THE EXISTING CITY FABRIC, AS WELL AS A NEW PLACE.

PUBLIC REALM PROPOSALS THAT CREATE HIGH QUALITY STREETS AND SAFE, ACCESSIBLE SPACES.

BUILDING HEIGHT, SCALE AND MASS THAT ARE RESPONSIVE TO THE HERITAGE OF THE SITE AND THE WIDER CITY SETTING AND CHARACTER.

CREATE AN APPROACH INCORPORATING BIODIVERSITY MEASURES AND SUSTAINABLE STRATEGIES.

CREATE A FLEXIBLE APPROACH TO DEVELOPMENT PLOTS AND BUILDINGS WHICH ARE ROBUST AND RESILIENT.

CREATE A FLEXIBLE PHASED APPROACH WHERE THE PLACE FEELS COMPLETE AT EVERY STAGE.

## 1.10 NOMENCLATURE

A set of names have been assigned to identify the different areas of the development, and for ease of reference across the Outline Application documents. These are intended for illustrative purposes only.

### 1.10.1 Character Areas and Development Zones

The site has been divided broadly into five Character Areas. These contain one or more Development Zones as set out by the Parameters Plans. The boundaries of the Character Areas are roughly aligned with the Development Zones according to the below layout.



### 1.10.2 Streets

A diagrammatic street network (based on the Illustrative Masterplan) is used throughout, in order to demonstrate the principles of the streets framework.

### 1.10.3 Components of the Masterplan Character Areas

Character Areas are broken down into key areas of public realm and sub areas with distinct characteristics relating to adjacent context.

#### NATIONAL RAILWAY MUSEUM

- 13 Museum
- 13a Museum Gateway (northern half of New Square)

#### STATION QUARTER

- 14 George Square
- 15 Cinder Yards
- 16 Station District
- 17 Wilton Place (a), Cinder Street (b) and Hudson Place (c)
- 18 Station Gateway (southern half of New Square)

#### YORK YARD SOUTH

- 19 York Yard Gateway
- 20 York Yard Parkside
- 21 York Yard Rise

#### FOUNDRY QUARTER

- 9 Foundry Village
- 10 Foundry Yard
- 11 Foundry Terrace
- 12 Leeman Yard
- 19 Foundry Square

#### CENTRAL PARK

- 1 Millennium Green
- 2 Reeds Garden
- 3 Stream Garden
- 4 Central Lawn
- 5 Amphitheatre
- 6 Gravel Garden
- 7 Garden Plaza
- 8 Museum South Yard

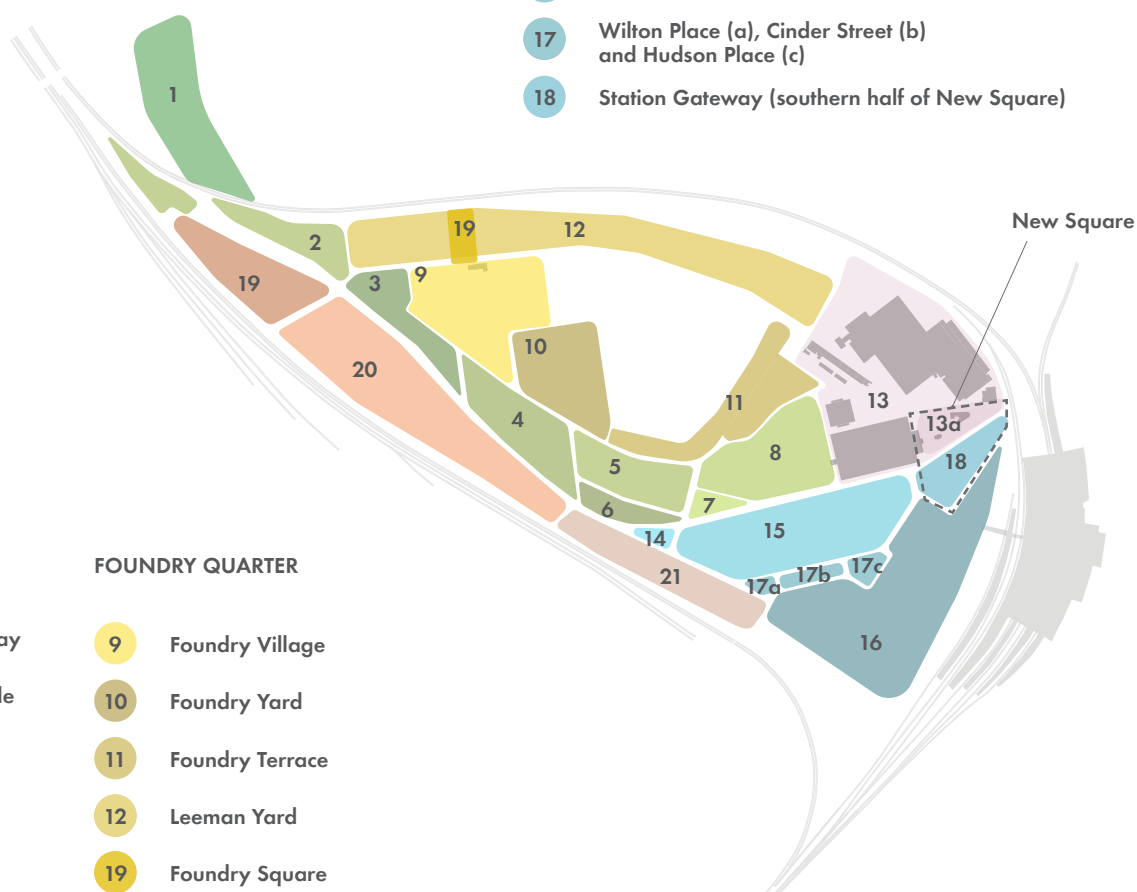

## 1.11 STRUCTURE OF THE DESIGN GUIDE

The Design Guide contains codes and guidance for all aspects of York Central, from site wide infrastructure, to the architecture and appearance of a building on a single plot. The document should be read according to the nature and scale of the RMA to come forward.



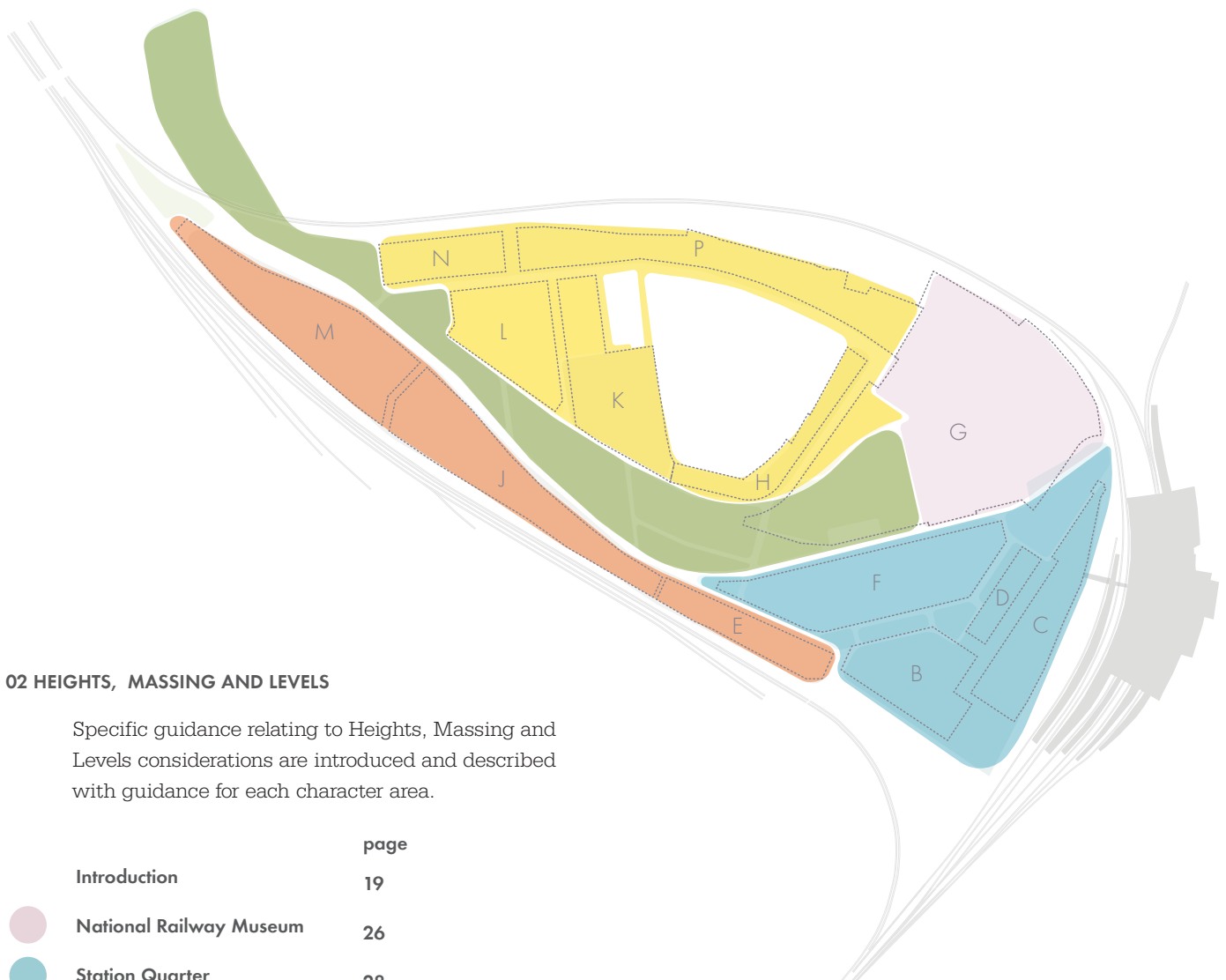

### 1.11.1 Navigating the Design Guide

The following diagrams can be used to locate specific guidance within the Design Guide. The diagrams illustrate where different chapters of guidance are located for the York Central site.



### 02 HEIGHTS, MASSING AND LEVELS

Specific guidance relating to Heights, Massing and Levels considerations are introduced and described with guidance for each character area.

	page
Introduction	19
 National Railway Museum	26
 Station Quarter	28
 York Yard South	34
 Foundry Quarter	38

03 PUBLIC OPEN SPACE

page

Key areas of Public Open Space are introduced and described with specific guidance for each space.

45

page

page

NEW SQUARE

64

STATION QUARTER

70

13a Museum Gateway (north half of New Square)

64

14 George Square 70

18 Station Gateway (south half of New Square)

66

15 Cinder Yards 71

17 Wilton Place (a), Cinder Street (b) and Hudson Place (c) 71



FOUNDRY QUARTER

Page

CENTRAL PARK

Page

19 Foundry Square 72

1 Millennium Green 58

5 Amphi theatre 60

10 Foundry Yard 73

2 Reeds Garden 59

6 Gravel Garden 61

3 Stream Garden 59



7 Garden Plaza 61

4 Central Lawn 60

8 National Railway Museum Yard 61

## 04 STREETS



The different possible street types and their relationship with public realm and building proposals are described with specific guidance in Chapter 04.

	page
Street hierarchy	78
Pedestrian connectivity	80
Cyclist connectivity	82
 Primary streets	86
 Secondary streets	102
 Tertiary streets	112

## 05 HERITAGE ASSETS

The approach to Heritage Assets is outlined in Chapter 05. This includes general principles and guidance by Character Area with reference to specific buildings existing on the site.



	page
Introduction	146
General guidance	148
 National Railway Museum	152
 Station Quarter	160
 Foundry Quarter	154



**06 APPEARANCE SITE WIDE**

page

Site wide guidance for appearance including: grain, 'foreground' buildings, roofs, windows, materials, and public infrastructure and services can be found in chapter 06.

**164**

**07 APPEARANCE BY CHARACTER AREA**

Additional guidance for each Character Area is provided in chapter 07.

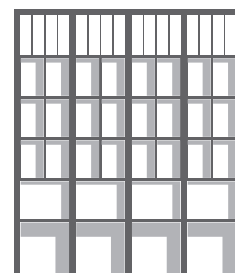
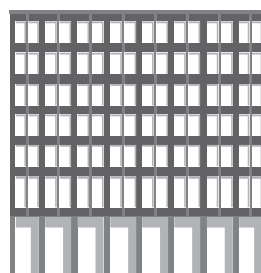

page

 Station Quarter

**201**

 York Yard South

**217**

 Foundry Quarter

**230**

**08 BUILDING TYPOLOGIES**

page

Specific guidance for different Building Typologies are described in chapter 08 this includes guidance around space standards, parking requirements and amenity space requirements.

**241**

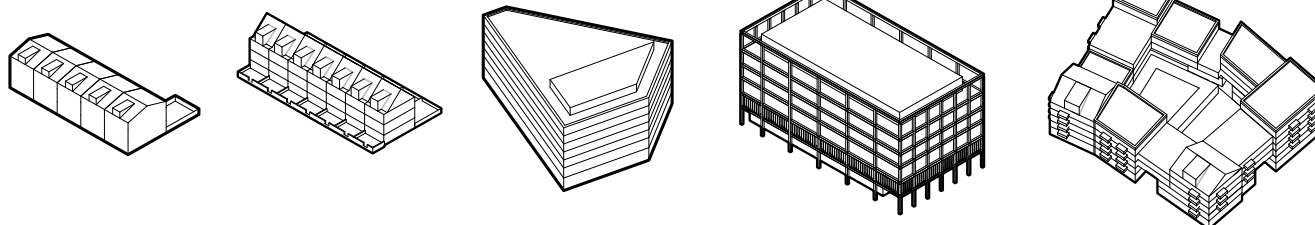

**09 SUSTAINABILITY**

page

Guidelines on sustainable principles that should be employed.

**265**

**08 GLOSSARY**

Definitions of terms used within the Design Guide.

**272**





## 2 HEIGHTS, MASSING AND LEVELS

This section outlines the principles of building heights, massing, site levels and the maximum developable extent of each Development Zone on the site. These principles and parameters have been developed with consideration of specific Townscape Views that must be achieved within the site and the appearance of the site from sensitive locations within the wider city.

Refer also to Environmental Statement Volume 01: Townscape and Vision Impact Assessment.

## 2.1 INTRODUCTION

This chapter discusses the maximum building heights, massing and site levels within the York Central site. The maximum developable extents are captured within the Parameters Plans. The following pages discuss a selection of the Parameters Plans most relevant to the heights and massing discussion and the various constraints that have informed them.

### 2.1.1 The Design Guide and Parameters Plans

The Design Guide and Parameters Plans work in combination to determine the maximum developable extents on the York Central site. These limits are intended to allow flexibility for any future RMAs and to preserve the considerations that have emerged in the course of the pre-application and engagement process with York's residents and businesses, CYC and Historic England.

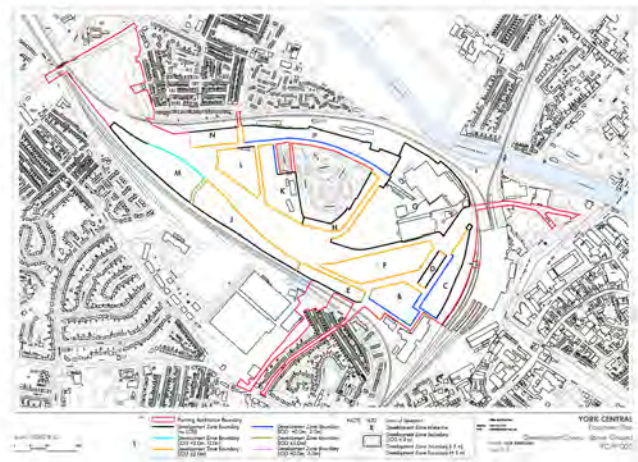

Fig.03 The York Central Parameters Plans are a suite of documents which make up part of the control documents for any Reserved Matters Application on the York Central site

### 2.1.2 PP 005 Development Zones Above Ground

PP 005 shows the different Development Zones and their maximum horizontal extents. The parameters for the Development Zones include limits of deviation between 0 and 5m according to specific site conditions which might relate to infrastructure, open space requirements, ground constraints (Holgate Beck), existing buildings and the railways. See "Fig.04 Parameter Plan 005 Development Zones - Above Ground"

**No development shall be permitted beyond the limits set out within the Parameter Plan with the exception of the following items which shall be permitted to project a maximum of 2m beyond the Development Zone: porches, balconies, garden walls, landscaping elements (below 4m), temporary structures (below 4m), tree planting.**

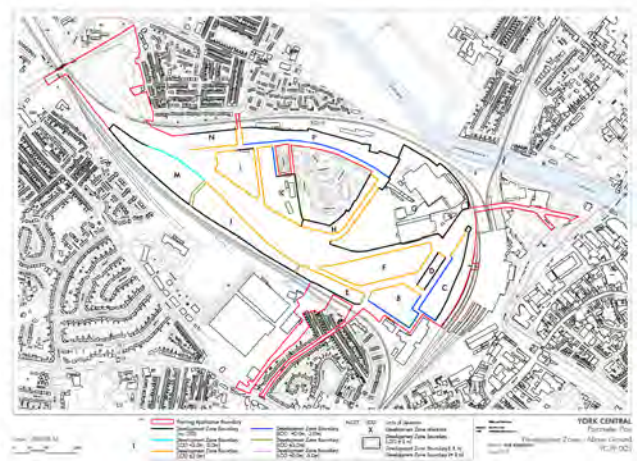

Fig.04 Parameter Plan 005 Development Zones - Above Ground

### 2.1.3 PP 010 Development Plots and Maximum Heights

YC PP 010 shows the maximum heights permissible within the scheme. These have been developed according to specific Townscape Views and massing heights and volumes deemed appropriate for this site within the wider context of the city of York.

**Heights given are AOD levels (above ordnance datum) and are therefore independent of any proposed site levels.**

**No development shall be permitted beyond the vertical limits set out within the Parameter Plan.**

**No vertical exemptions shall be permissible.**

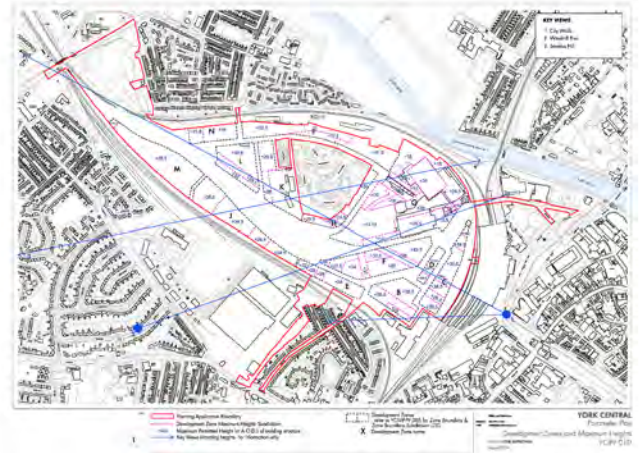

Fig.05 Parameter Plan 010 Development Plots and Maximum Heights

### 2.1.4 YC PP 011 Proposed Site Levels

PP 011 shows the limits of deviation permissible for new site levels. This has particular relevance where the Development Zones contain existing buildings and accesses.

Levels for public open space are constrained by proposed and existing infrastructure; existing buildings and developments, for example the National Railway Museum and St Peter's Quarter. Flood defence and landscape setting determine the levels for Central Park and the Millennium Green.

**No site levels shall be permitted beyond the range set out within the Parameter Plan.**

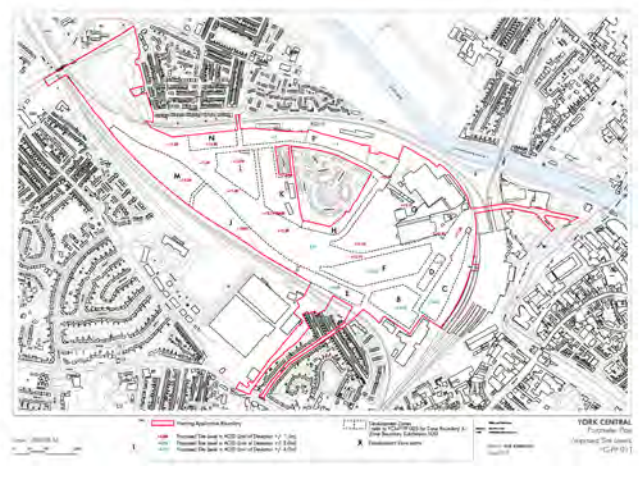

Fig.06 Parameter Plan 011 Proposed Site Levels

### 2.1.5 YC PP 006 Access and Circulation Routes

PP 006 shows the requirements for access and circulation within the masterplan application area.

**The access routes shown form the primary and secondary street framework. Tertiary streets, Foot streets, Play streets and snickets, within Development Zones are not shown but must be provided. See chapter 04 Streets.**

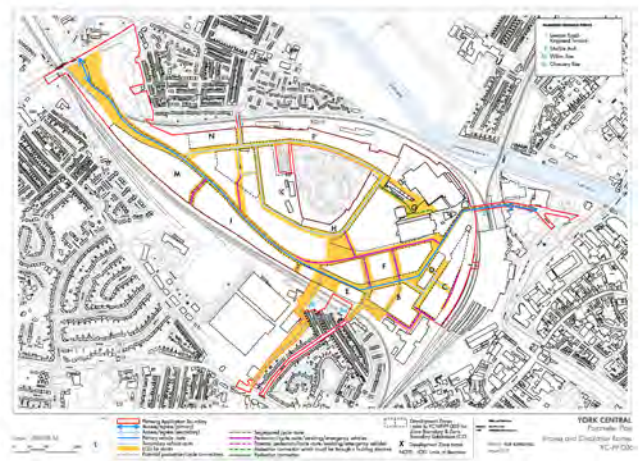

Fig.07 Parameter Plan 006 Access and Circulation Routes

## 2.2 MAXIMUM DEVELOPABLE EXTENTS

### 2.2.1 Maximum Developable Extents

Volumetric limits set by the Design Guide and Parameters Plans can be considered as the 'Maximum Developable Extents' (MDE) of the site.

The MDE will determine the limits of development at every scale.

The limits of the MDEs exist to allow for required open space; to create scope for pedestrian permeability and to protect key Townscape Views and visual permeability (refer to Environmental Statement Vol 01: Chapter 09 Townscape and Visual); and to generate an appropriate urban grain on the site.

**In order to adhere to the Design Guide and Parameters Plans, any Reserved Matters Application for Development Plots must sit within the maximum developable extents of a specific Development Zone.**

The MDEs are sized to allow for different massing arrangements and flexibility in design.

The MDEs are defined by both the Design Guide and the Parameters Plans.

The final relationship between the massing of any Reserved Matters Application and the maximum developable extents will be subject to the consideration of CYC planning department.

### 2.2.2 Exemptions

**The following items shall be exempt from massing restrictions and may project beyond the Development Zone boundary and shall be permissible outside of the Development Zones by agreement with the LPA through the RMA process:**

- porches, balconies, garden walls, landscaping elements (below 4m), temporary structures (below 4m).
- No permanent vertical exemptions shall be permissible.
- Parameters have not been set for bridges, trees, public art. These all fall outside the Development Zones and shall be permissible.

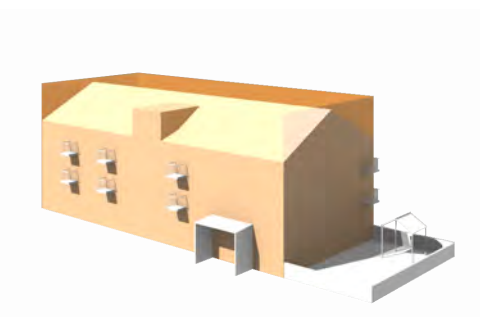

Fig.08 Compliant scheme with excepted elements shown

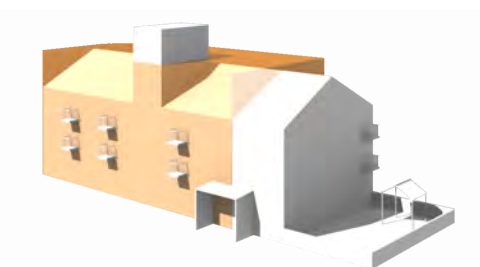

Fig.09 Non compliant scheme

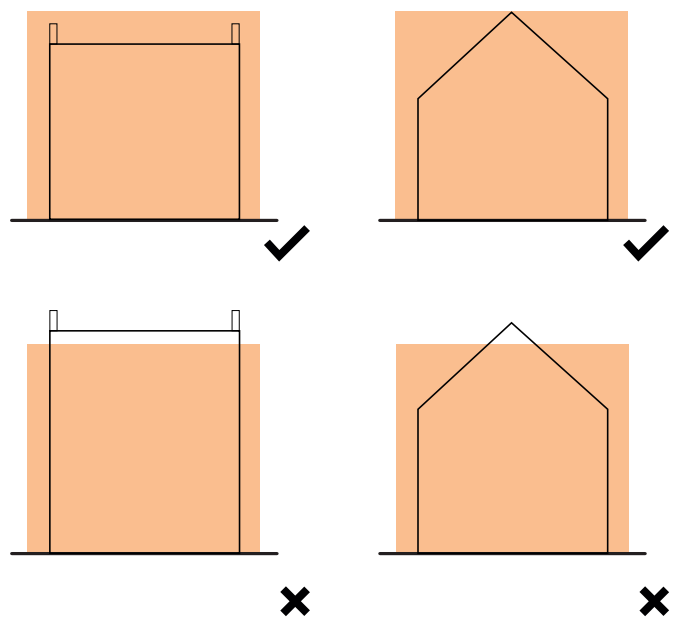

Fig.10 Height constraints within the maximum building envelope

Maximum developable extents

## 2.3 VISUAL PERMEABILITY

---

### 2.3.1 Visual permeability

In addition to volumetric measures, there may be additional considerations which need to be addressed within any RMAs on the site.

Permeability is a key feature of the existing urban fabric in York. Details of movement and routes through the site are detailed in Chapter 04: Streets, but **consideration must also be given to visual permeability and views through the site to landscape or historic features of York.**

## 2.4 TOWNSCAPE CONSIDERATIONS

### 2.4.1 Townscape views

The visual impact of the scheme on different view points in the wider city of York has been discussed in detail as part of the pre-application engagement process for the outline application for York Central.

**All RMAs should refer to Environmental Statement Volume 01 for a full and detailed assessment of Townscape Views.**

The following pages relate to townscape considerations for three specific Townscape Views: Bouthwaite Drive, City Walls and Holgate Windmill, where the impact of the illustrative scheme has needed to be carefully managed.

These views have been identified to help understand and illustrate the impact of the proposals on the site's and city's heritage. There are numerous other view points and places from which people experience other connections.

The following pages provide guidance on the known constraints resulting from these views for each character area.

**RMAs shall be required to test the scheme against specific Townscape Views subject to relevance and review by the Local Authority and Historic England.**

### 2.4.2 Roofscape

Roofscape proposals will have a significant impact on the perceived view of the development from different views in wider city.

For discussion of roofscape and appropriate grain please refer to Chapter 06 Appearance Site Wide.

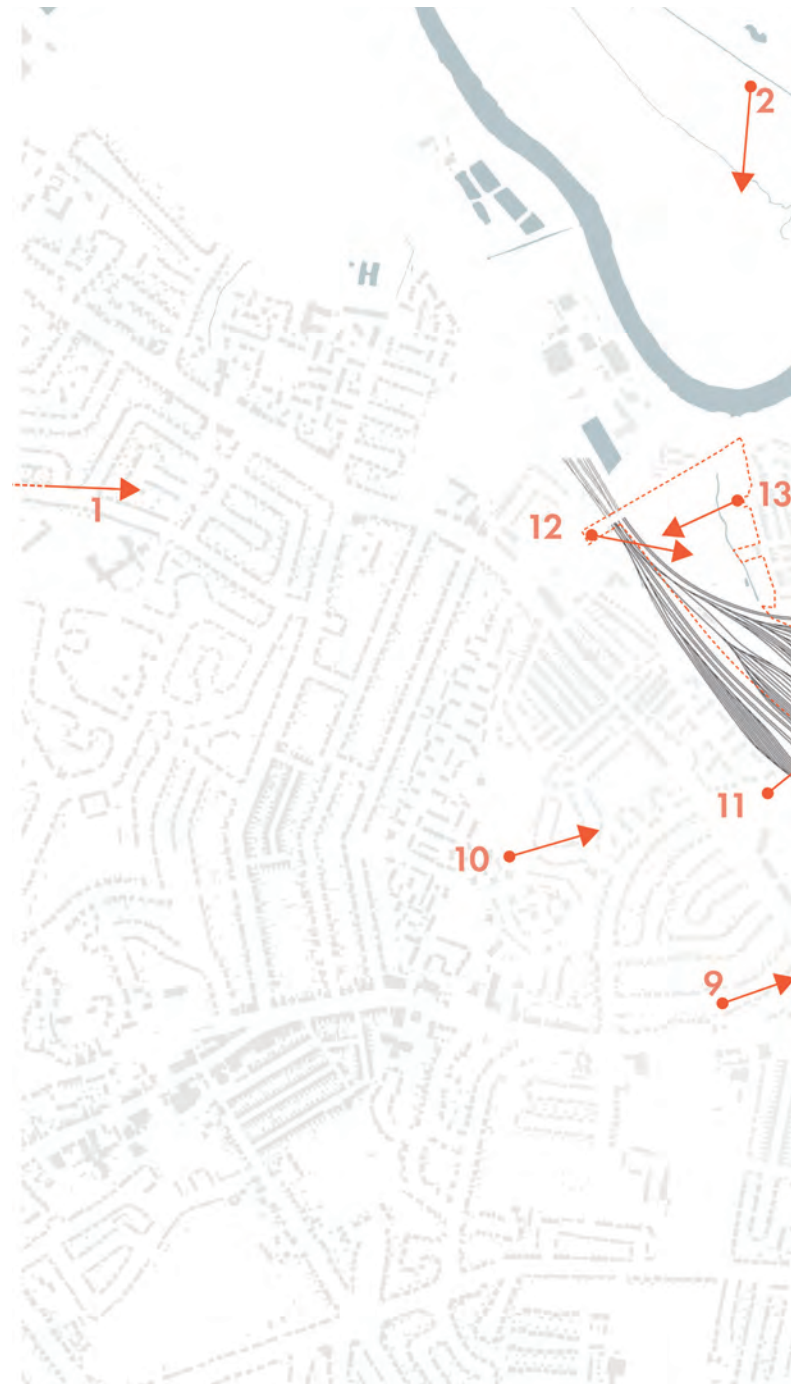
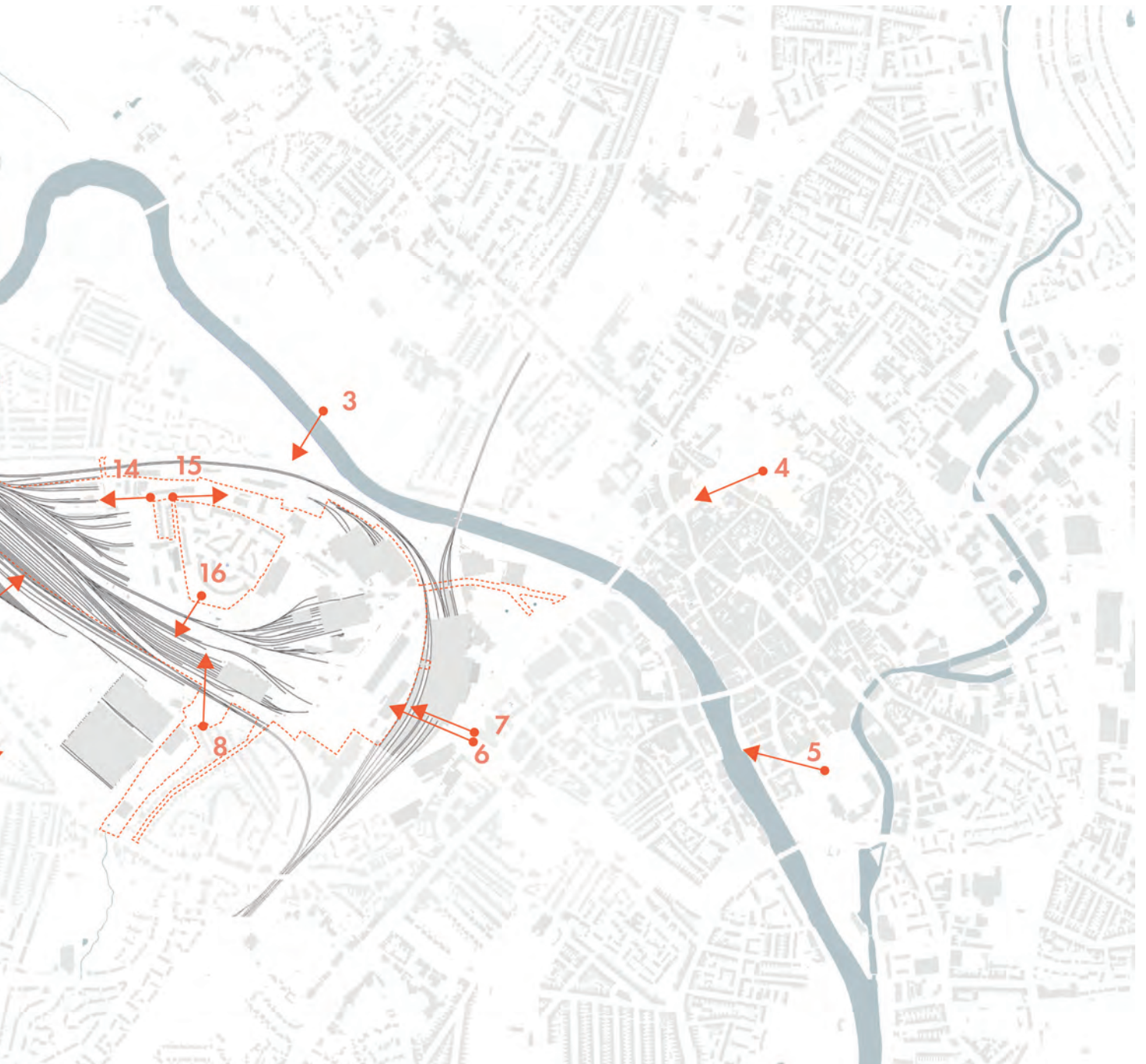

Fig.11 Townscape Views city wide



- |   |   |    |  |
|---|---|----|--|
| 1 | Beckfield Lane/Almsford Road (Key View 8)     | 9  | Holgate Windmill, Windmill Rise              |
| 2 | York & Selby Path, NCR 65, Clifton Ings       | 10 | Bouthwaite Drive, Severus Hill               |
| 3 | York & Selby Path, NCR 65, Clifton Long Reach | 11 | Park on Poppleton Road                       |
| 4 | York Minster                                  | 12 | Water End Bridge (Key View 10)               |
| 5 | Clifford's Tower                              | 13 | Garnet Terrace/ Leeman Road Millennium Green |
| 6 | City Walls                                    | 14 | Leeman Road looking west                     |
| 7 | Queen Street, York Station                    | 15 | Leeman Road looking east (Key View 11)       |
| 8 | Cleveland Street/Upper St Paul's Terrace      | 16 | Bishopfields Drive                           |

## 2.5 NATIONAL RAILWAY MUSEUM: DEVELOPMENT ZONE G

The National Railway Museum will be the cultural heart of the York Central Site. It is a museum of local, national and international significance. The parameters for Development Zone G have been developed to enable its future expansion.

The quality of the design and delivery of new space at the National Railway Museum is of paramount importance to the Museum and its parent Science Museum Group. In line with all recent major projects delivered by Science Museum Group, an extensive and consultative design process will be followed, working with world class architects, to create the optimum proposals for the functional requirement, setting and York context and planning policy. There will be on-going consultation with residents and stakeholders as design options are generated and assessed. The commitment to quality in design and delivery is absolute. The Museum will be cognisant of the quality of the existing City of York built environment and the quality of York Central.

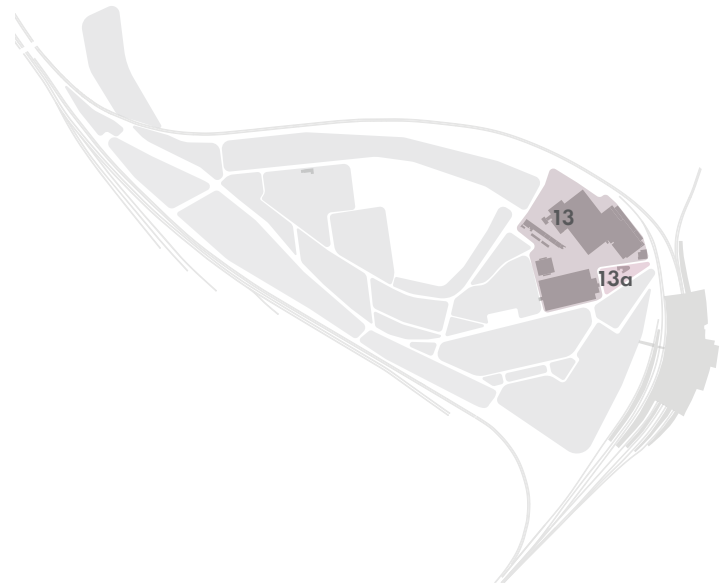

NATIONAL RAILWAY MUSEUM

- 13 Museum
- 13a Museum Gateway

### 2.5.1 Maximum building heights

The maximum building heights in Development Zone G are driven in large part by the existing structures on the site - the National Railway Museum and heritage buildings in the vicinity.

Heights given are AOD levels (above ordnance datum) and are therefore independent of any proposed site levels.

**No development shall be permitted beyond the vertical limits set out within the Parameters Plans.**

**No permanent vertical exemptions shall be permissible.**

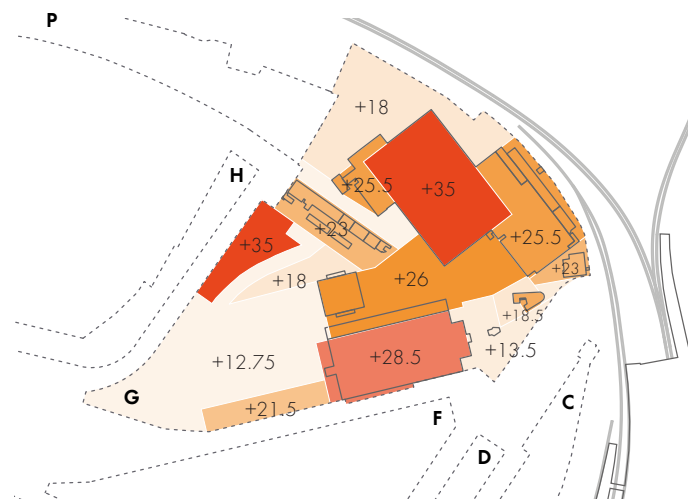
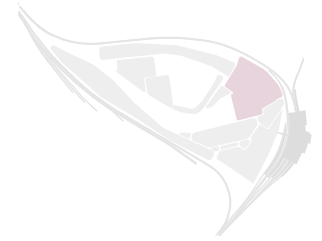

Fig.12 Development Zone G height plan showing maximum development height (AOD)





**2.5.2 Limits of Deviation**

The Limits of Deviation set out by Parameter Plan 005: Development Zones - Above Ground determines the enclosure of the public realm and streets.

In the Museum Quarter these limits have been driven mainly by the primary infrastructure network - streets and access to the public transport (Station access/bus stops/cycle routes).

**Any proposals in proximity to existing retained buildings or the National Railway Museum buildings must be cognisant of existing maintenance and access requirements and allow flexibility for any future requirements. Entrances will be provided from the Museum Square and from the western side of the Museum.**

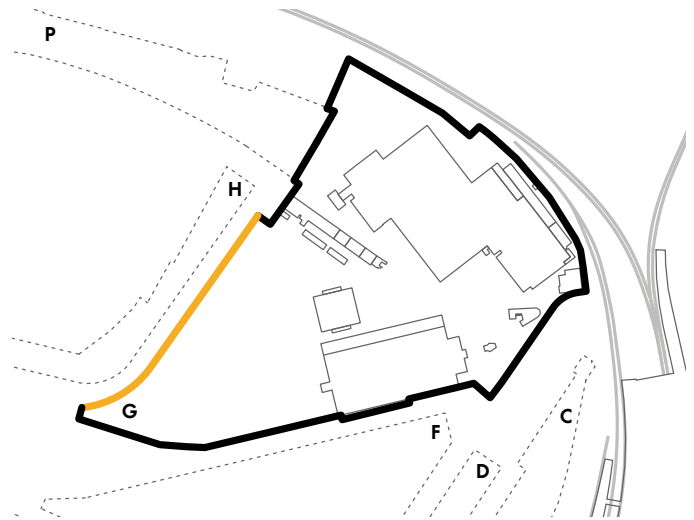

Fig.13 Limits of deviation on the Development Zones within the Museum Quarter

- Development Zone Boundary (LOD ±2.0m)
- Development Zone Boundary (LOD ±0.0m)

**2.5.3 Townscape and visual permeability**

When evolving development proposals around the National Railway Museum the applicant must be cognisant of the particular sensitivities that relate to Townscape Views. Refer to (Environmental Statement Vol 1:Chapter 09)

In developing designs for any new buildings the National Railway Museum will give careful consideration to views to and from the Minster, City Walls and Railway Station.

The view from Holgate Windmill to York Minster has particular impact on the massing potential and buildings heights in the Museum Quarter

The view from Bouthwaite Drive to York Minster is also a significant consideration.



Fig.14 The view of York Minster from Holgate Windmill impacts heights and massing in York Yard South, Foundry Quarter and Station Quarter



Fig.15 View of York Minster from Bouthwaite Drive impacts heights on Foundry Village, York Yard South, Museum Quarter and the northern most plots of the Station Quarter

## 2.6 STATION QUARTER: DEVELOPMENT ZONES B, C, D & F

The Station Quarter will be a new destination for businesses, for tourists and for local residents alike. It will provide a new access to the mainline railway station and be defined by its high quality public space: New Square, Cinder Yards, Hudson and Wilton Place. The design parameters for this quarter are driven by townscape and place making considerations and transport infrastructure requirements.

### STATION QUARTER

- 14 George Square
- 15 Cinder Yards
- 16 Station District
- 17 Wilton Place (a), Cinder Street (b) and Hudson Place (c)
- 18 Station Gateway (southern half of New Square)



### 2.6.1 Maximum building heights

The maximum building heights in the Station Quarter are driven mainly by place making considerations and Townscape Views from York's City Walls.

**Heights given are AOD levels (above ordnance datum) and are therefore independent of any proposed site levels.**

**No development shall be permitted beyond the vertical limits set out within the Parameter Plan.**

**No vertical exemptions shall be permissible.**

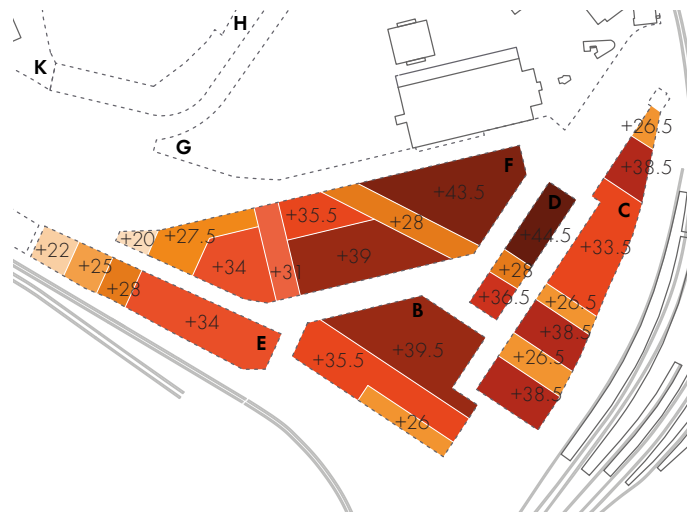

Fig.16 Station Quarter heights plan showing maximum development heights (AOD)



### 2.6.2 Limits of Deviation

The Limits of Deviation set out by Parameter Plan 005 Development Zones Above Ground determines the enclosure of the public realm and streets.

In the Station Quarter these limits have been driven mainly by the primary infrastructure network - streets and access to the public transport (Station access/bus stops/cycle routes).

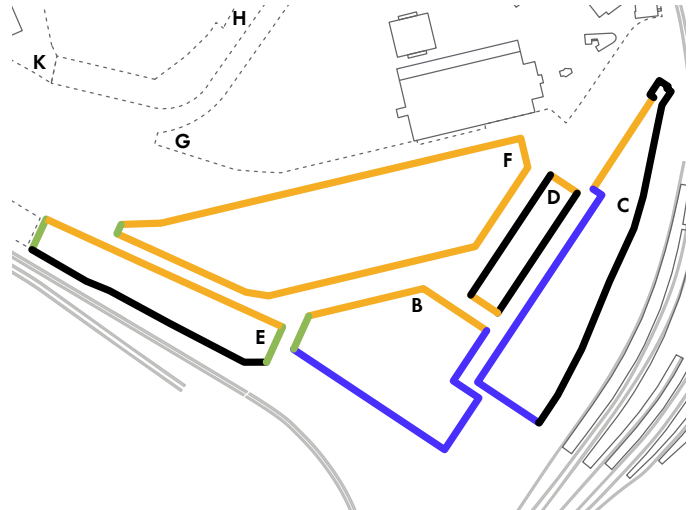

**Fig.17** Limits of deviation on the Development Zones within the Station Quarter

- Development Zone Boundary (LOD ±2.0m)
- Development Zone Boundary (LOD ±0.0m)
- Development Zone Boundary (LOD ±5.0m)
- Development Zone Boundary (LOD + 0.0m, -2.0m)

### 2.6.3 Access and circulation

The station quarter incorporates the passage of the primary road network through the site. In addition to the requirements shown on Parameter Plan 006 pedestrian and cycle connectivity must be promoted with links through and between blocks.

See Chapter 04 Streets.

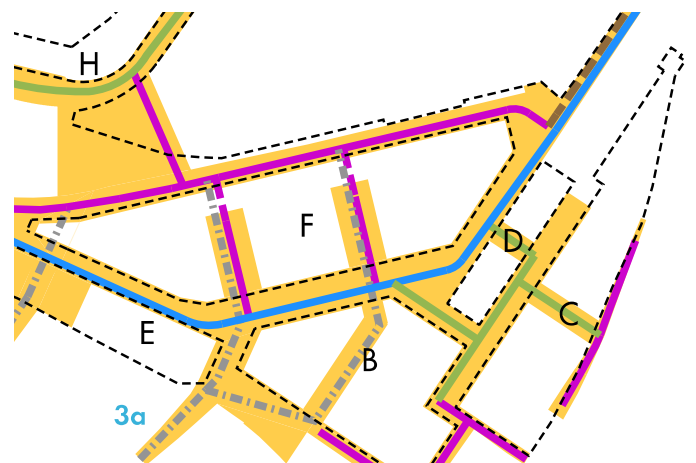

**Fig.18** Movement and access requirements within the Station Quarter

- Limit of deviation
- Primary vehicular route
- Pedestrian/cycle route/servicing/emergency vehicles
- Secondary vehicle route
- - - Potential for pedestrian/cycle connections

## 2.6.4 Cinder Yards

It is intended that Development Zone F incorporate two to three 'Yard' spaces. These are intended to assist with daylighting and service access for the adjacent buildings, and to provide break out spaces for residents and people working. It is intended that where possible these are publicly accessible and form part of the pedestrian movement network for the site. See Chapter 04 'Streets'.

**The distribution, size and proportion of these Yards shall be subject to the daylighting and access requirements for the adjacent buildings.**

**Spaces shall be well overlooked with active ground floor frontages and building entrances.**

**The design of delivery and service access on the Cinder Yards shall be integrated within the architectural composition of the facade.**

**Vehicle access will be for delivery/servicing/emergency vehicles only. Access and egress points must be considered as part of the elevation design of the courtyard spaces.**

**A minimum of two pedestrian access/egress points shall be provided. These should take the form of 'snickets' See Chapter 04 'Streets'**

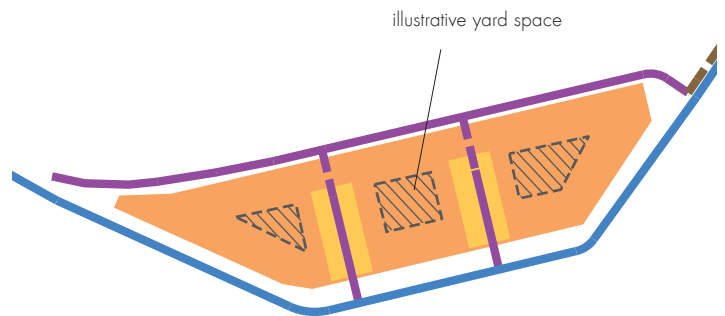

Fig.19 Development Zone F showing possible distribution of Cinder Yards with primary and pedestrian routes shown

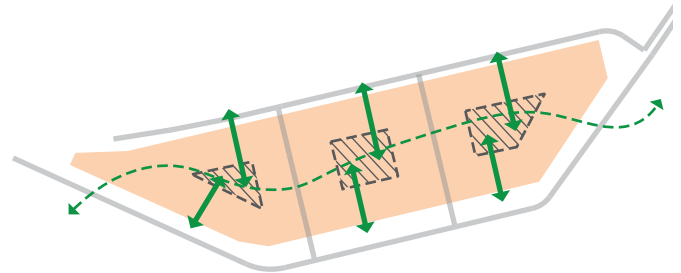

Fig.20 Pedestrian connections should be facilitated across the Yards between the two streets. East - west pedestrian connections are also desirable



Fig.21 Cinder Yards and snickets shown with a possible massing arrangement

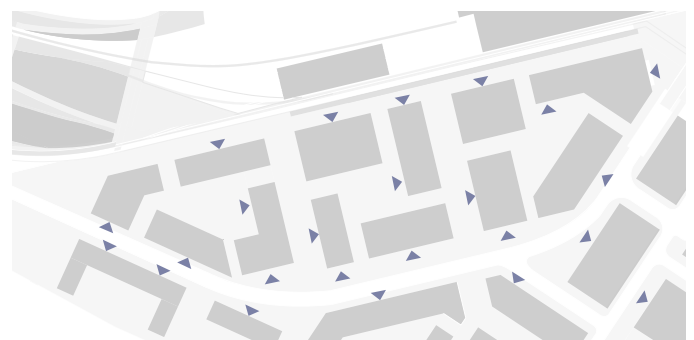

Fig.22 Cinder Yards shown with possible building entrances



**2.6.5 Station Gateway (New Square - South)**

Building lines along the south-east and south-west of Station Gateway must be perpendicular - Development Zones C & D.

A bull-nose or straight edged massing arrangement must complete the eastern most end of Development Zone F.

The frontage of Development Zone F must not interrupt the direct view from the station exit to the first arch in the side wall of the National Railway Museum.

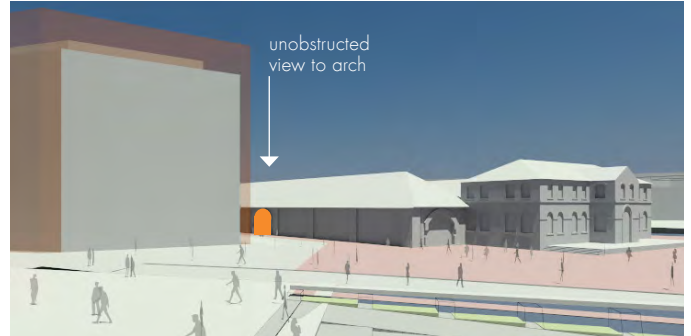

Fig.23 View from station exit looking towards NRM with unobstructed view of existing archway

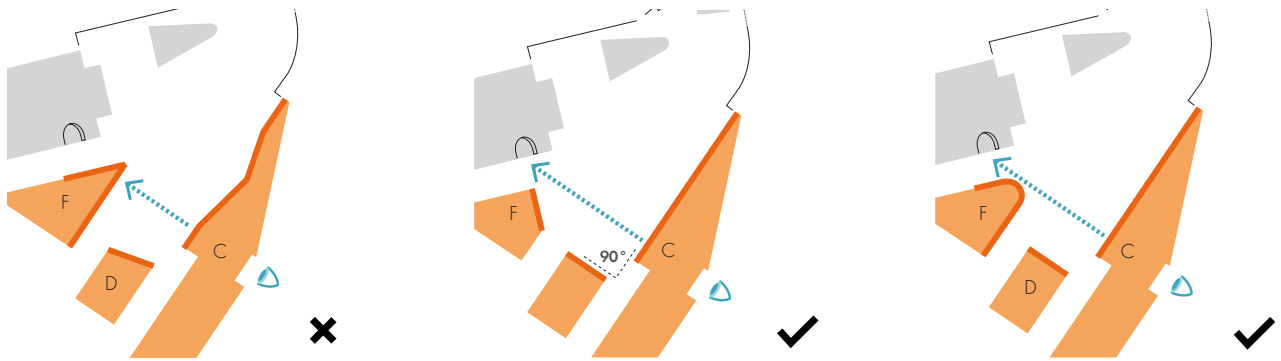

Fig.24 New Square view towards arch of Railway Museum

**2.6.6 Cinder Street Hudson Place and Wilton Place**

Cinder Street, Hudson Place and Wilton Place are envisaged as a connected sequence of public realm components within the Station Quarter. These spaces will be fronted by a mix of retail, commercial and residential frontages.

Building lines must be parallel with a regular alignment.

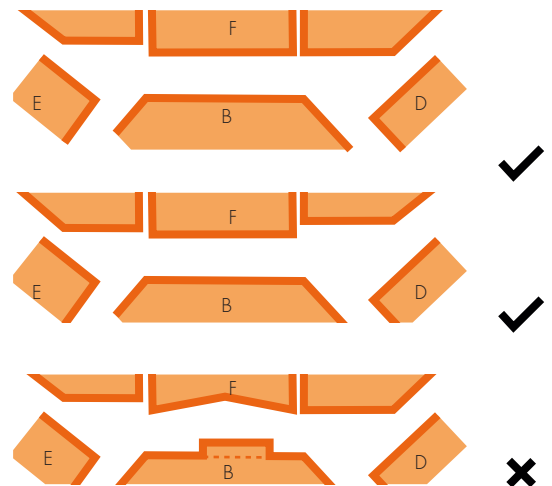

Fig.25 Cinder Street

---

### 2.6.7 George Square

Buildings facing onto George Square shall provide a strong edge with a linear, robust and unbroken building frontage.

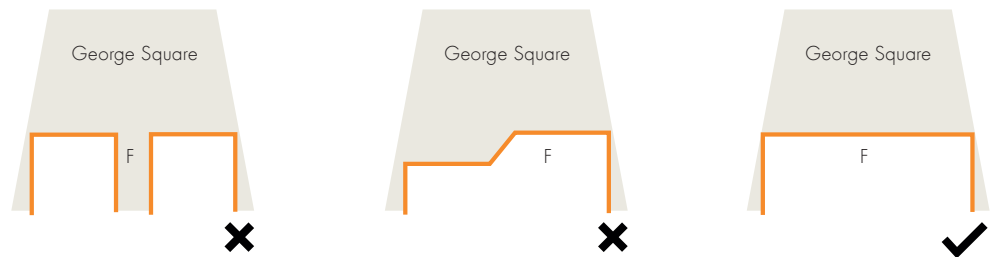

Fig.26 Diagrams showing acceptable and unacceptable George Square building arrangements in plan

---

### 2.6.8 Townscape and visual permeability: City Walls

The view from the City Walls has particular impact on the massing potential and buildings heights in the Station Quarter.

**Building massing on the site must allow views of the near horizon of the moraine.**

**Building massing on the site must allow views of the distant horizon of the Yorkshire Dales.**

**Building massing that appears above the station roofline must be cognisant of the views from the City Walls. Building plant must be concealed or integrated within the built envelope. Exposed plant shall not be acceptable.**



Fig.27 Implications of view from City Walls on illustrative scheme



Fig.28 Existing view from York City Walls

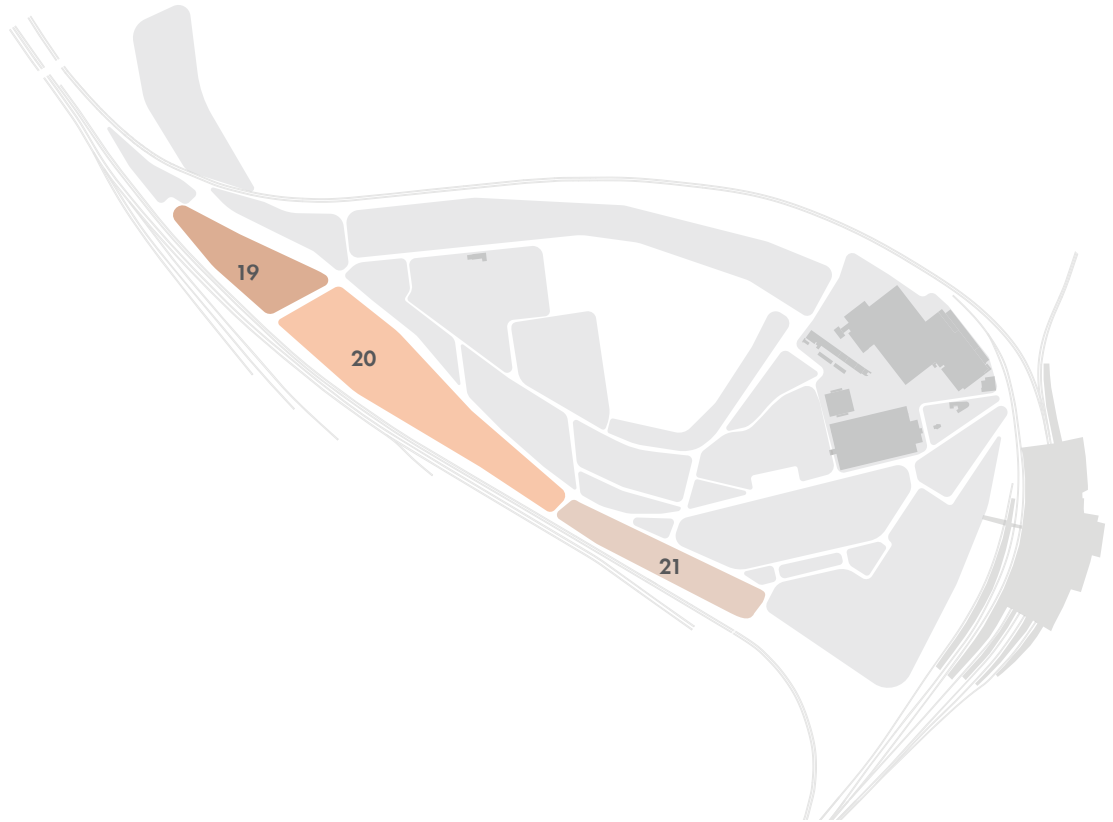

Fig.29 View from City Walls shown with Illustrative Masterplan



Fig.30 Massing constraints relating to view from City Wall

## 2.7 YORK YARD SOUTH: DEVELOPMENT ZONES M, J & E



### YORK YARD SOUTH

- 19 York Yard Gateway
- 20 York Yard Parkside
- 21 York Yard Rise

### 2.7.1 Maximum building heights

The maximum building heights in York Yard South have been determined by consideration of key Townscape Views across the site to York Minster, the appearance of the site from adjacent local context and how the massing in these zones frames Central Park.

Development Zones M and J form the south western edge of the site. Layering of massing, visual permeability and pedestrian permeability will be key to delivering successful development.

**Heights given are AOD levels (above ordnance datum) and are therefore independent of any proposed site levels.**

**No development shall be permitted beyond the vertical limits set out within the parameter plan.**

**No vertical exemptions shall be permissible.**

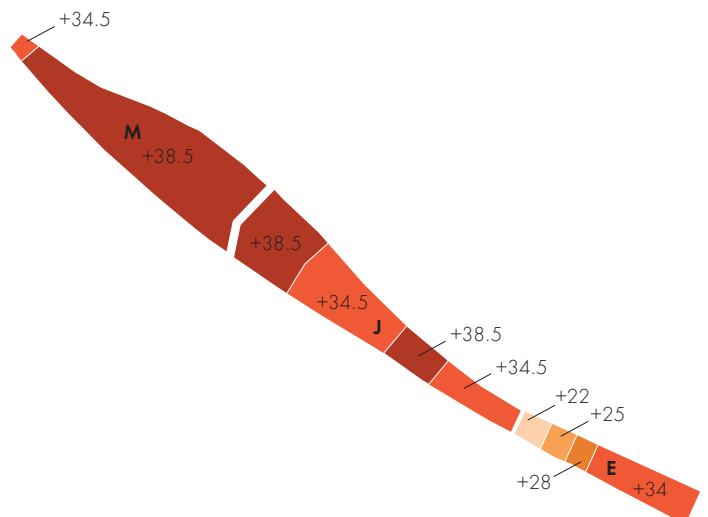
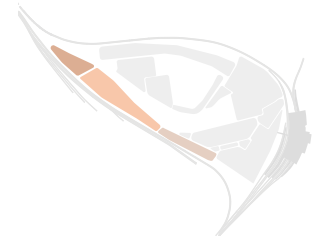

Fig.31 Principles of maximum developable envelope plan

- Maximum permitted Height +21,5 m (+ 34,50 m AOD)  
0,5 m - gap between tallest building within the Development Zone
- Maximum permitted Height +25,5 m (+ 38,50 m AOD)  
2,00 m - gap between tallest building within the Development Zone
- Allow for cut through the blocks





### 2.7.2 Layered building heights: York Yard Gateway

York Yard Gateway provides a key vista of the York Central site.

Building heights should step down towards the bridge approach from Millennium Green.

#### Massing shall be layered.

In Development Zone M this layered approach, is intended to integrate the heights with the wider context. The layering is also intended to mediate between the 'openness' of Millennium Green/ Central Park and the westernmost buildings of York Yard South.

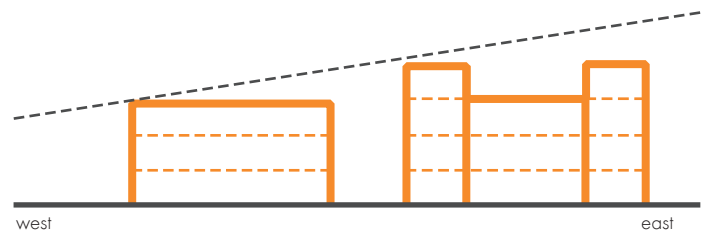

Fig.32 Illustrative section showing layering of building heights at York Yard Gateway

### 2.7.3 Limits of Deviation

The limits of deviation set out by Parameter Plan 005: Development Zones - Above Ground determines the enclosure of the public realm and streets.

In York Yard South these limits have been driven mainly by the primary infrastructure network and adjacent railways.

- Development Zone Boundary (LOD ±2.0m)
- Development Zone Boundary (LOD ±0.0m)
- Development Zone Boundary (LOD ±5.0m)
- Development Zone Boundary (LOD + 0.0m, -2.0m)
- Development Zone Boundary (LOD +2.0m, -0.0m)
- Development Zone Boundary (LOD +0.0m, -5.0m)



Fig.33 Limits of deviation on the Development Zones with York Yard South

### 2.7.4 Access and circulation

York Yard South incorporates the passage of the primary road network through the site. In addition to the requirements shown on Parameter Plan 006 Pedestrian Connectivity must be promoted with links through and between blocks and the incorporation of play streets. See Chapter 04 Streets.

**Existing access to the adjoining rail infrastructure must be retained.**

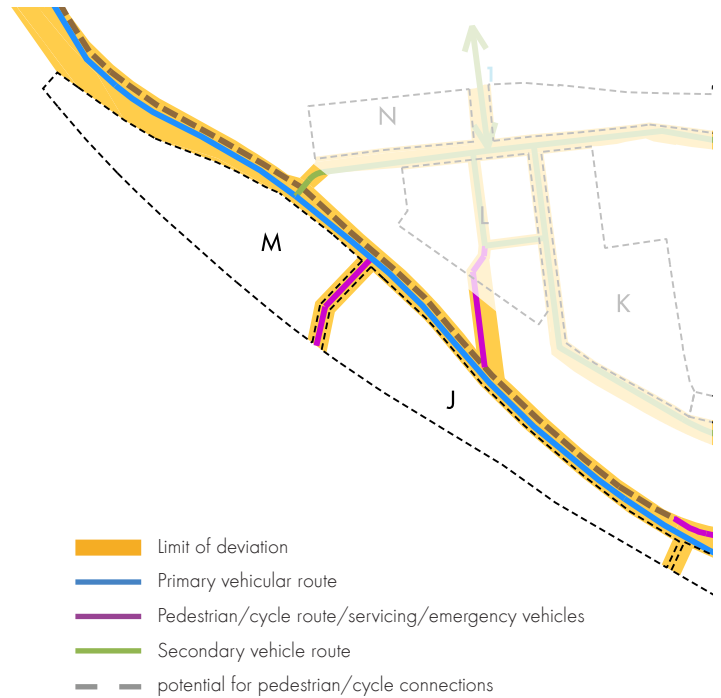

Fig.34 Movement and access requirements Yard South

### 2.7.5 Townscape and visual permeability: Bouthwaite Drive and Holgate Business Park

The massing seen from Bouthwaite Drive is predominately in the York Yard South Area. Development Zones M and J are most visible.

Height and massing constraints have been determined to ensure the following:

**The silhouette of York Minster must be unobstructed within the view as shown (right).**

**The massing for each development parcel must allow glimpses between blocks which reveal the horizon line at regular intervals.**

**The view from Holgate Business Park must form a varied and layered elevation to the York Central site. Cut throughs and openings between blocks shall allow visual permeability.**

**Each Reserved Matters Application is responsible for ensuring that visual permeability is achieved through York Yard South. Early phase developments may not assume that later developments will provide the necessary visual permeability.**



Fig.35 Views of the York Minster from Bouthwaite Drive must be protected this has driven some of the height parameters in Development Zone M and J

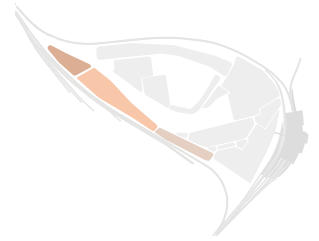
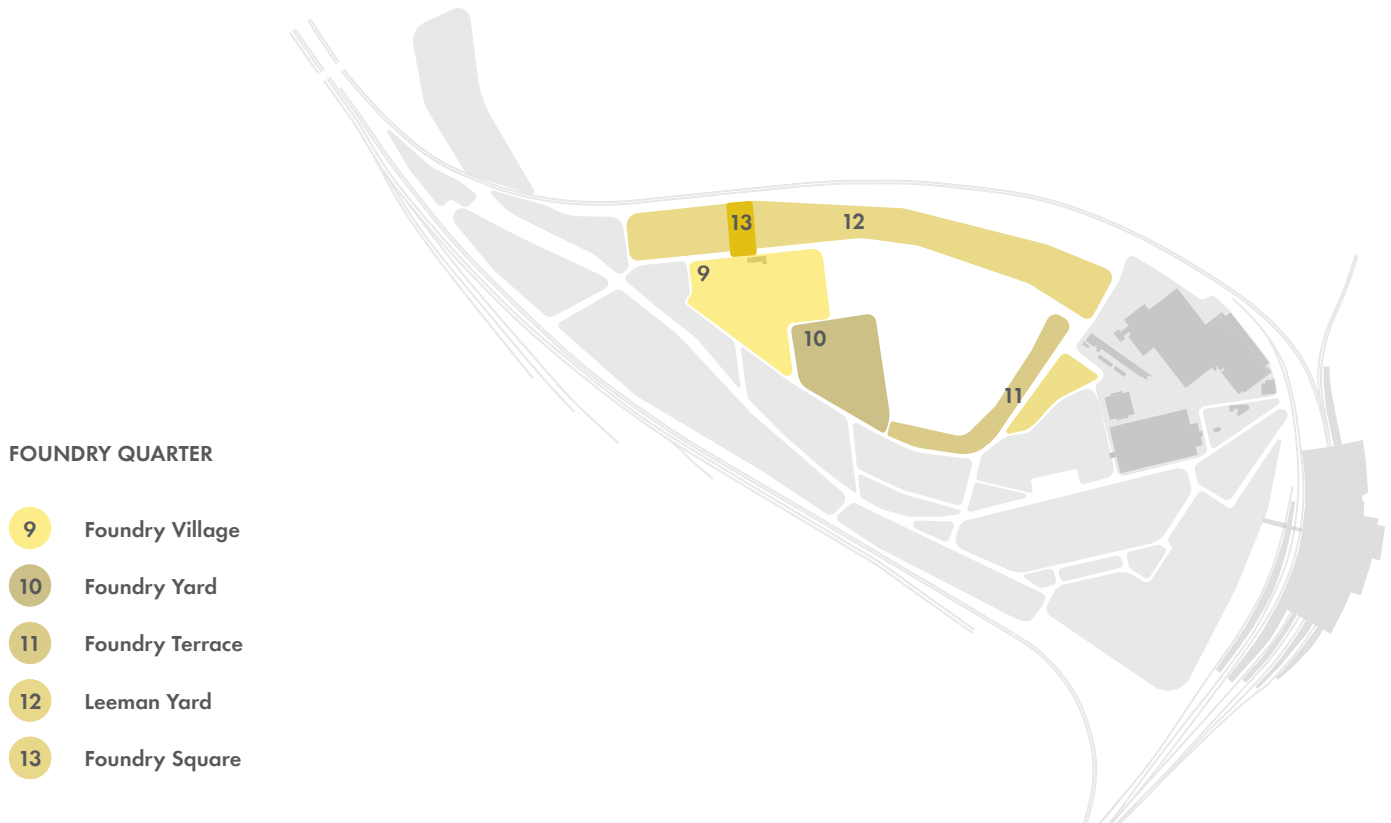

Fig.36 Existing view from Bouthwaite Drive



Fig.37 Illustrative Masterplan with maximum developable extents highlighted in orange

## 2.8 FOUNDRY QUARTER: DEVELOPMENT ZONES H, K, L, N, P



### 2.8.1 Maximum building heights

The maximum building heights in the Foundry Quarter have been determined by consideration of key townscape including views across the site to York Minster, and the relationship of the site with the existing neighbourhoods of St Peters Quarter and Salisbury Terrace.

**Heights given are AOD levels (above ordnance datum) and are therefore independent of any proposed site levels.**

**No development shall be permitted beyond the vertical limits set out within the parameter plan.**

**No vertical exemptions shall be permissible.**

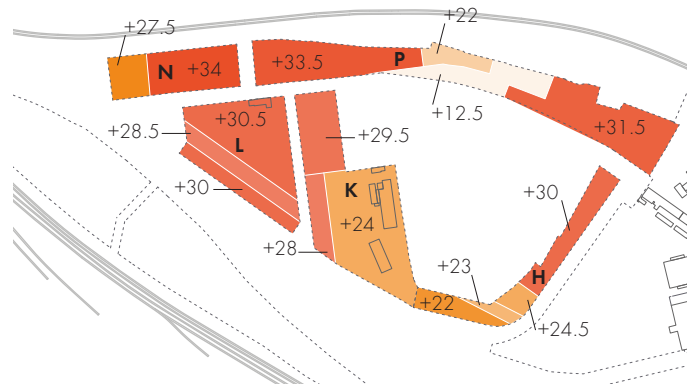
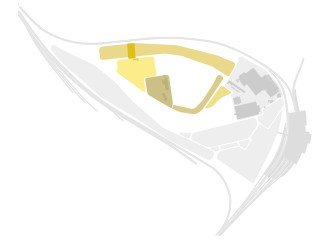

Fig.38 Foundry Quarter heights plan showing maximum development heights

### 2.8.2 Townscape and visual permeability

Multiple views from around the city have helped to determine the parameter heights and massing of the Foundry Quarter.

For a full discussion of Townscape considerations please refer to Environmental Statement Vol 1: Chapter 9.



### 2.8.3 Limits of Deviation

The limits of deviation set out by Parameter Plan 005 Development Zones Above Ground determines the enclosure of the public realm and streets.

In the Foundry Quarter these limits have been driven mainly by the primary infrastructure network, adjacent railway lines and the existing St. Peters Quarter.

- Development Zone Boundary (LOD  $\pm 2.0m$ )
- Development Zone Boundary (LOD  $\pm 0.0m$ )
- Development Zone Boundary (LOD  $\pm 5.0m$ )
- Development Zone Boundary (LOD  $+ 0.0m, -2.0m$ )
- Development Zone Boundary (LOD  $+2.0m, -0.0m$ )
- Development Zone Boundary (LOD  $+0.0m, -5.0m$ )

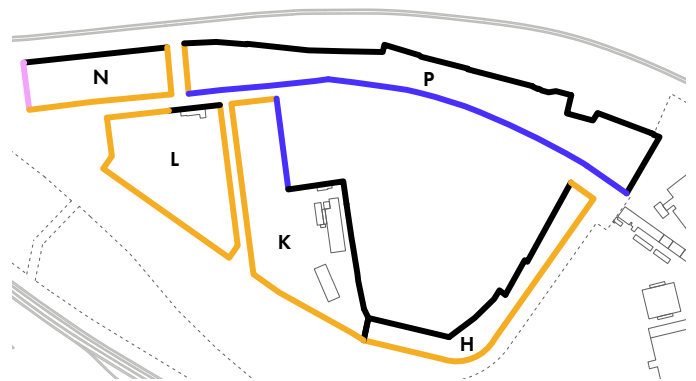

Fig.39 Limits of deviation on the Development Zones Foundry Quarter

### 2.8.4 Access and circulation

The Foundry Quarter is accessed by a network of secondary streets. In addition to the requirements shown on Parameter Plan 006 Pedestrian Connectivity must be promoted with links through and between blocks and the incorporation of play streets.

See Chapter 04 Streets.

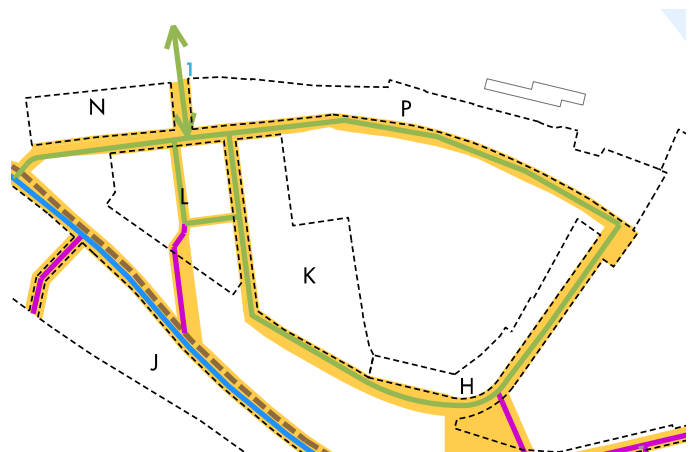

Fig.40 Movement and access requirements within the Foundry Quarter

- Limit of deviation
- Primary vehicular route
- Pedestrian/cycle route/servicing/emergency vehicles
- Secondary vehicle route

**2.8.5 Stream Garden edge**

Buildings facing onto the Stream Garden edge must form a consistent edge to the open space.

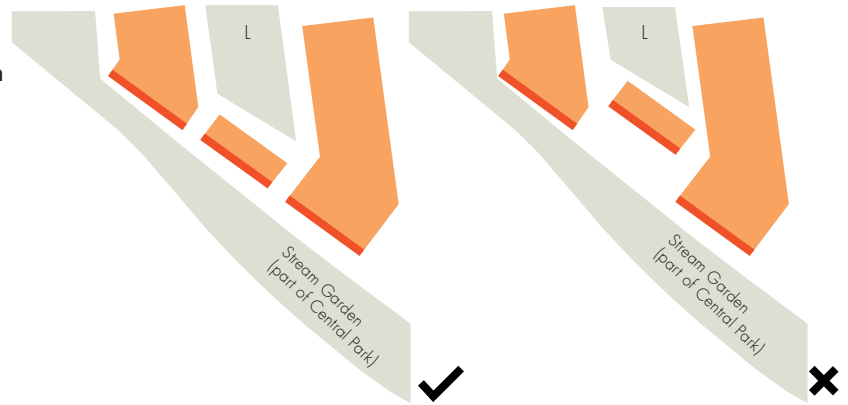

Fig.41 Stream Garden edge alignment

**2.8.6 Development Zone P - interface with National Railway Museum boundary**

Any building developments adjacent to the western boundary of the National Railway Museum shall be set back a minimum distance of 5m.

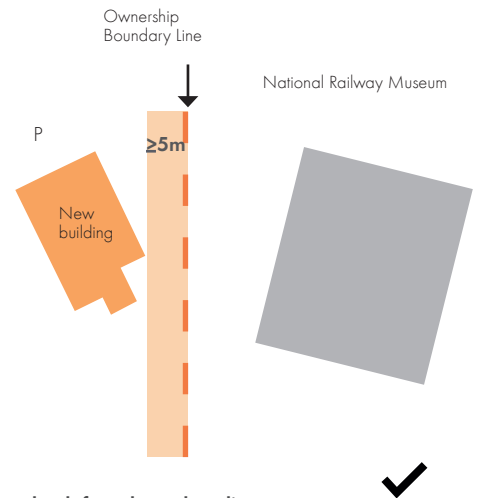

Fig.42 New building set back from boundary line

**2.8.7 Foundry Square**

The building lines to the east and west of the Kingsland Terrace site entrance must maintain a minimum face to face distance of 25m in addition to a view of a portion of the Foundry Village Pub elevation.

A minimum distance of 5m must be maintained between the building line of the Foundry Pub Village and carriageway.

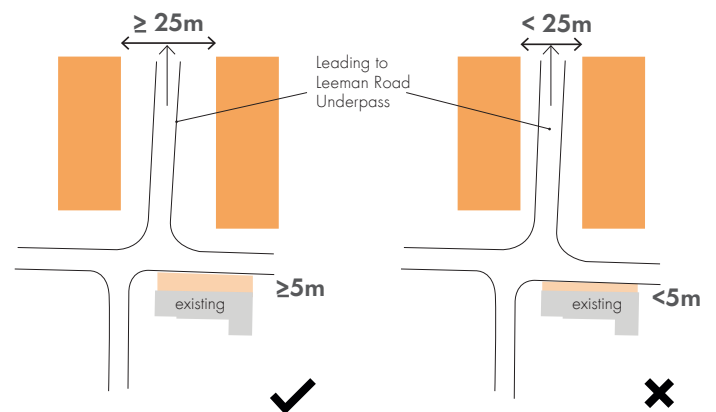
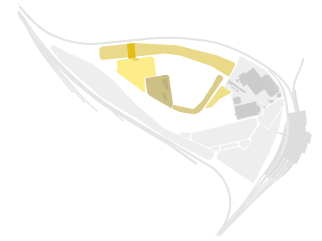

Fig.43 Foundry Square showing minimum extents



### 2.8.8 Foundry Yard

The design and placement of new buildings forming Foundry Yard shall be cognisant of the original arrangement of the Albion Foundry Yard, and the enclosure formed by the now demolished Phoenix Iron Foundry (A), the Smith's Shop and Office (B) and the Erecting and Fabrication Shop (D).

**Together with retained buildings (the Albion Iron Foundry Shop (C) and the Albion Iron Foundry Warehouse (E) ) new buildings shall form an open space of a similar scale and character to the original foundry yard.** The new buildings and extensions should have a scale and robustness similar to the existing Foundry buildings.

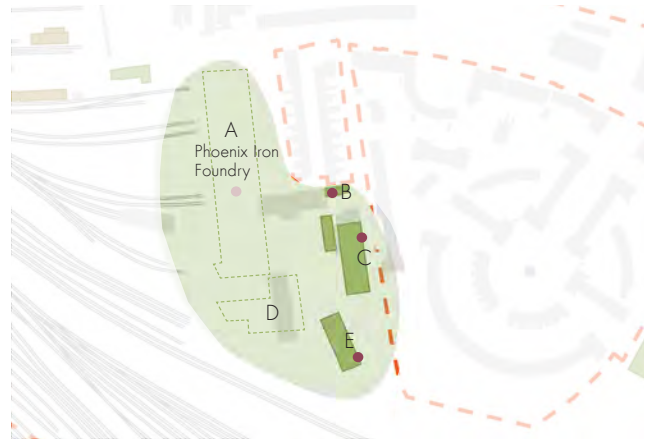

Fig.44 The grouping of existing buildings in Foundry Yard

**Building lines to the north and west of the site must be parallel to the existing Albion Iron Foundry shop.**

**The new yard should have yard proportion, not a street width.**

**The amount of original brick frontage visible around the new yard shall be maximised.**

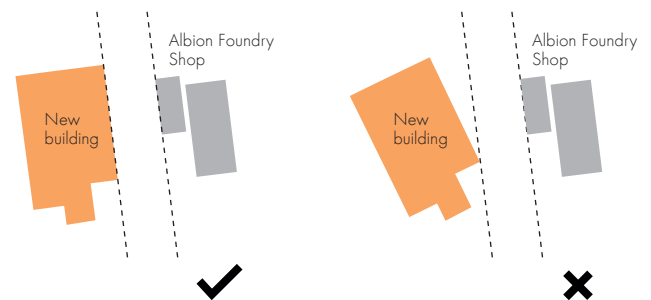
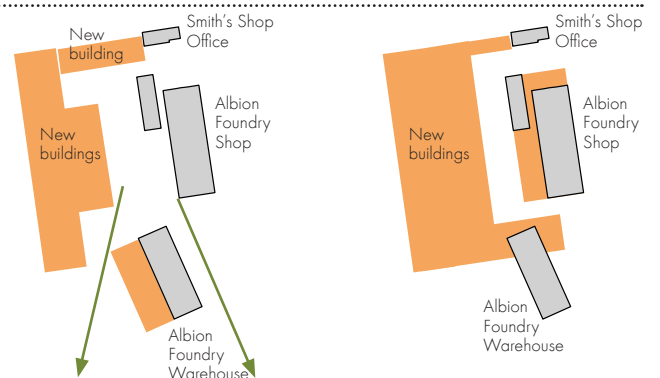

Fig.45 Alignment of new buildings in Foundry Yard

**The Foundry Yard shall not be fully enclosed. There shall be views through to the park from the Yard between buildings.**

A new building on the footprint of the former Smith's Shop should enclose a 'gateway' into the Foundry yard in a similar way to the former building.



Wide proportion yard  
Views out to park  
Plenty of original brick facade visible ✓

Narrow proportion yard,  
Totally enclosed  
Little visible original brick facade ✗

Fig.46 Example arrangements of Foundry Yard

### 2.8.9 Townscape and visual permeability

Multiple views from around the city have helped to determine the parameter heights and massing of the Foundry Quarter.

For a full discussion of Townscape considerations please refer to Environmental Statement Vol 1: Chapter 9.

**The silhouette of York Minster must be unobstructed.**

**The massing for each development parcel must allow glimpses between blocks which reveal the horizon line at regular intervals.**

**The view from Holgate Business Park must form a varied and layered elevation to the York Central site. Cut throughs and openings between blocks shall allow visual permeability.**

**Each Reserved Matters Application is responsible for ensuring that visual permeability is achieved through the Foundry Quarter. Early phase developments may not assume that later developments will provide the necessary visual permeability.**

**Building massing on the site must allow views of the near horizon of the moraine.**

**Building massing on the site must allow views of the distant horizon of the Yorkshire Dales.**

**Building massing that appears above the station roofline must be cognisant of the views from the City Walls.**

The view from Holgate Windmill to York Minster has particular impact on the massing potential and buildings heights on Foundry Terrace and the eastern extents of Leeman Yard.



Fig.47 View of York Minster from Bouthwaite Drive

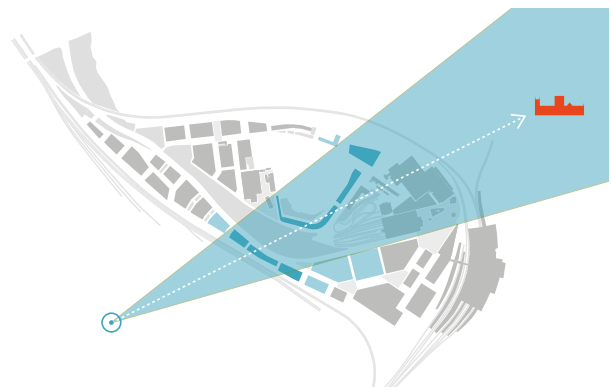

Fig.48 View of York Minster from Holgate Windmill

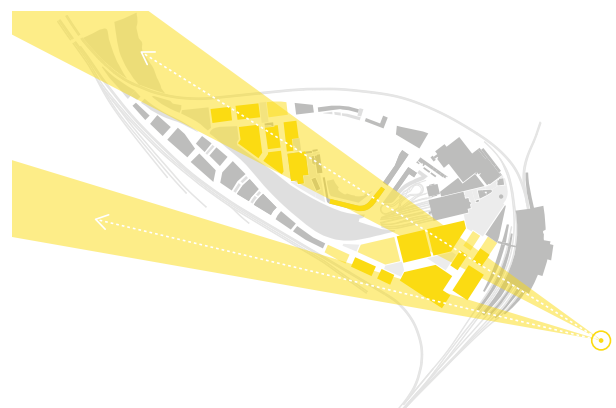
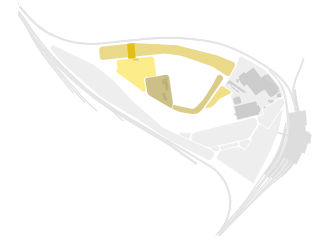

Fig.49 View from City Walls





**2.8.10 Leeman Road West - kinetic view sequence**

York Minster is currently visible from numerous locations along Leeman Road. The York Central Parameters Plans seek to maintain views of the west front of York Minster as you travel west to east along Leeman Road.

In the current streetscape, the West Front of the Minster starts to be revealed adjacent to the junction with Carlisle Street, reaching its fullest extent adjacent to Carleton Street (aligned with the Carleton Street frontage). Adjacent to the pedestrian crossing point at Martins Court (St Peter’s Quarter) the Minster is partly obscured by the Hertz sign, and the whole tableau then begins to be obscured by the Siemens building.

The following Townscape requirements must be incorporated into any RMA in the Foundry Quarter:

**1-3. The view of York Minster will be partial and fleeting as you progress towards the hill.**

**4. As you crest the hill, opposite St Peter’s Quarter, the full West Front of York Minster shall be revealed, framed with the Chapter House to the left.**

**5-6. As you progress further, the tower of the St Wilfred’s catholic church shall be revealed.**

**Any Reserved Matters Application must be cognisant of the view of York Minster and allow partial and full western views of the Minster as described.**

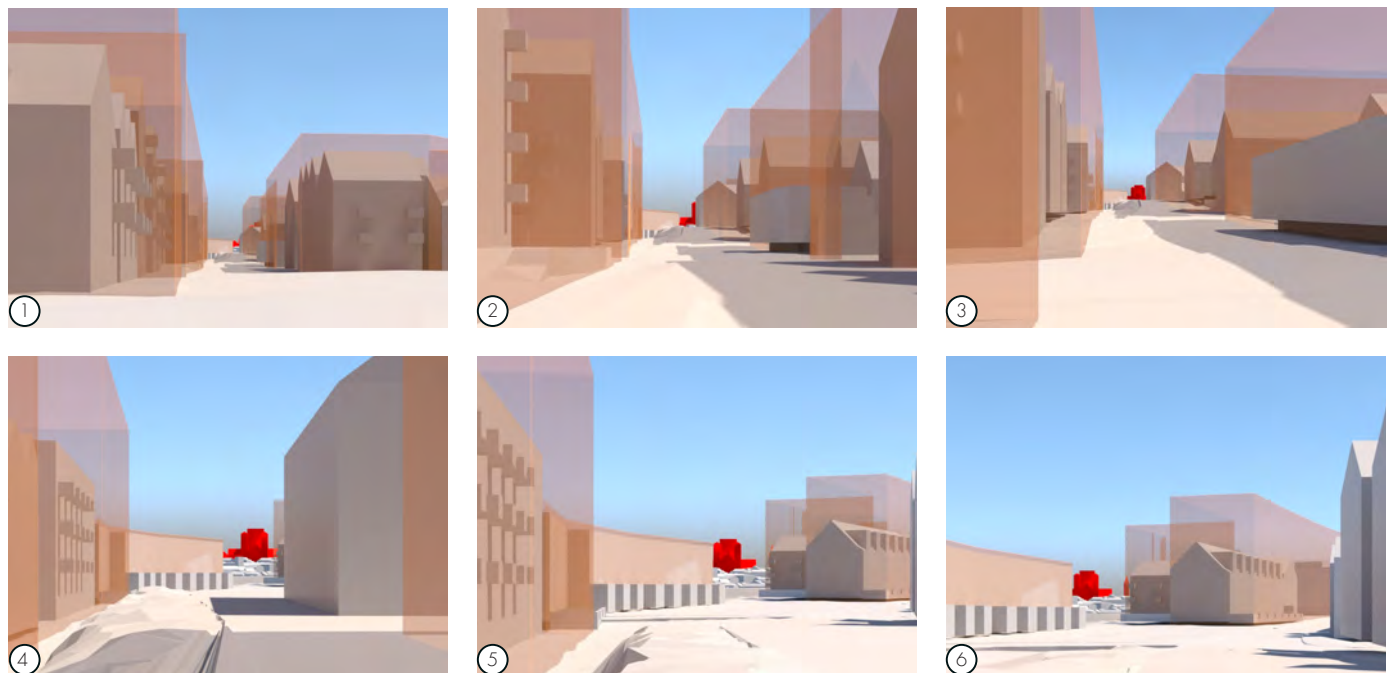

Fig.50 Leeman Road West view sequence of York Minster

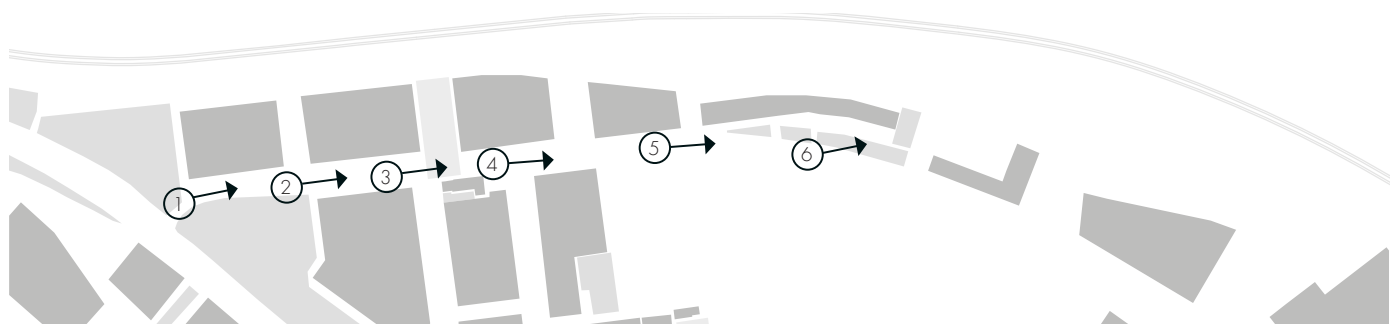

Fig.51 Diagram showing location of view sequence



## 3 PUBLIC OPEN SPACE

This section explains the principles, strategies and proposals for the landscape and public realm within the Masterplan; the character and qualities of the spaces that have been proposed; and how the landscape should mediate between the various development uses, architectural styles and scales, to create a sense of place.

## 3.1 LANDSCAPE STRATEGY

York Central will provide a high-quality public realm comprising a diverse series of open spaces, each with their own distinct character and opportunities. The envisaged landscape strategy and principles for the public open space will foster a special urban character whilst allowing for the flexibility required to respond to changing demands and adapt to the future development of York Central.

The landscape strategy creates a linear sequence of open spaces that transition between the dense urban contexts of the city centre in the east to the natural open landscapes of the River Ouse to the north-west. These spaces range from urban public squares to open parkland, and will create a compelling landscape which is at a scale appropriate to the historic city of York. Furthermore, the spaces will act as a public 'front door' to the National Railway Museum.

The open spaces within the Masterplan draw on York Central's unique history to create a rich tapestry of places giving a distinct and authentic sense of place. The most visible aspect of York Central's past is its railway heritage; from the presence of the National Railway Museum, its former goods yard, train sheds and railway sidings to the empty engineering sheds, foundries and depots that once supported its activities. The existing site remains as a testament to its former industrial past with a sinuous layout of tracks, rusting carriages, railway ballast and sleepers. The strategy is to utilise this language and these elements. By updating them, they will provide a contemporary setting for new events, amenity spaces for people, and habitats for wildlife.

The landscape strategy encourages the mitigation of human impact on climate change through the recycling of existing site materials and the use of innovative low-impact, yet high-quality, materials that are durable and sustainably sourced.

The following core principles shall be observed when designing open spaces within the York Central Masterplan:

**Promote a pedestrian and cycle friendly public realm;** ensuring high quality cycle and foot paths provide accessible, safe and convenient routes to and through the Masterplan area and enhance connectivity to the surrounding neighbourhoods and the city centre.

**Provide flexible open spaces that can be used for a diverse range of uses:** designed to maximise usability and accommodate a variety of community events, sport, play and informal gatherings.

**Provide a safe, accessible and inclusive environment for all visitors and members of the community:** promoting opportunities for passive surveillance of open spaces by maximising potential activity levels and ensuring pathways and bridges on the main circulation routes have a maximum gradient of 1:20.

**Utilise a design language and material palette that reflects the site's railway heritage:** retaining existing features and drawing on the unique character and history of the site to inform a design response.

**Implement a sustainable and resilient approach to water management:** utilising Sustainable Urban Drainage Systems (SUDS) to better manage surface water runoff and shaping the landforms of open spaces to create areas that can be used for the retention of water in extreme rainfall and flooding scenarios (refer to **3.3 "Sustainable urban drainage"**).

The Museum will ensure that proposed changes to its open spaces are complimentary to the York Central public realm.

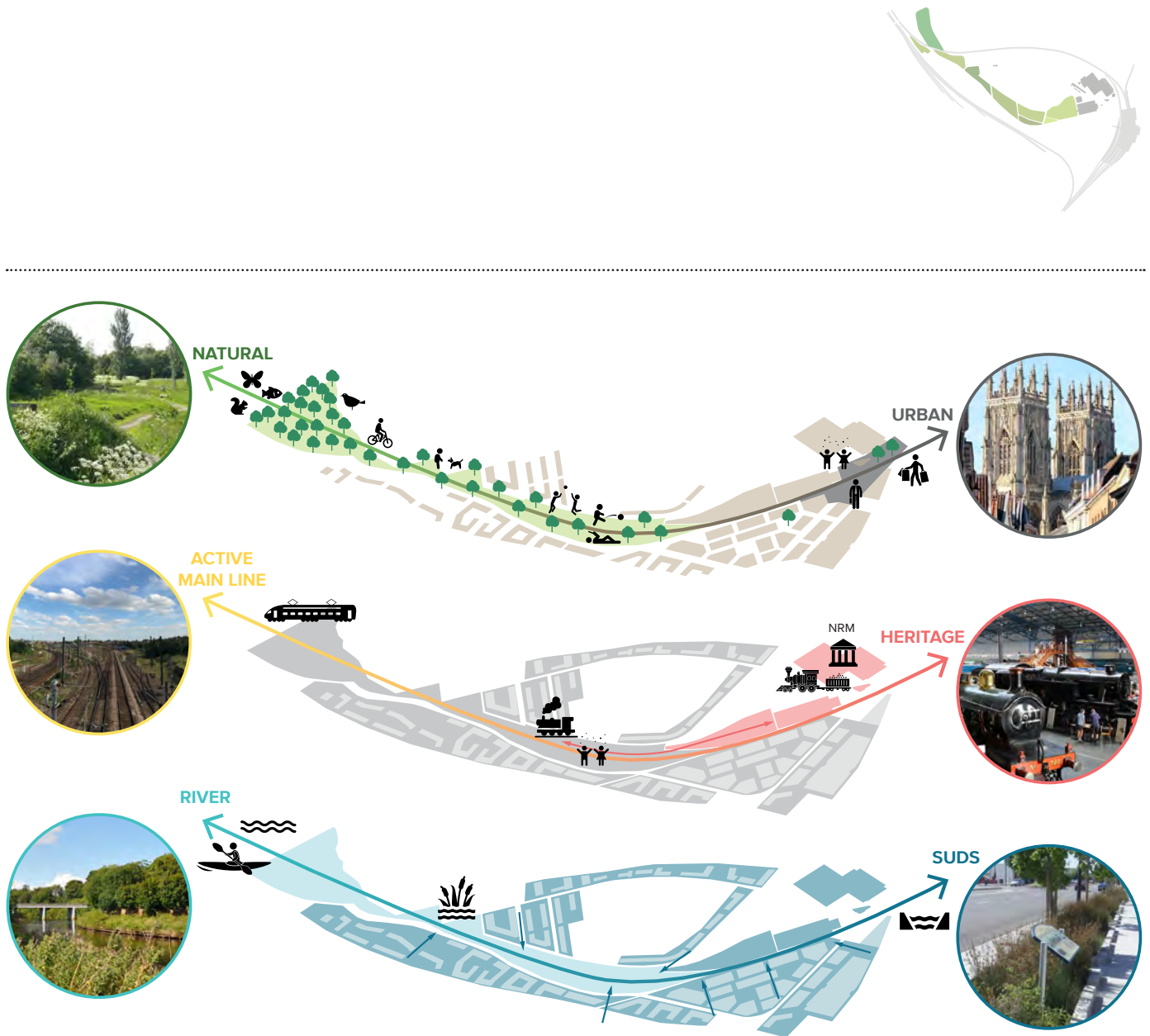

Fig.52 York Central landscape principles diagram

The above diagram describes the 3 main strands of the landscape strategy:

- Transition from natural to urban: York Central's landscape strategy creates a linear sequence of open spaces that transition between the urban contexts of the city centre to the natural open landscapes of the River Ouse.
- Railway heritage and identity: a green spine connects the National Railway Museum, a celebration the nation's railway history, to the active main line linked by a visitor train ride.
- Blue infrastructure: Sustainable Urban Drainage Systems (SUDS) integrated within the open space network increase the development's resilience to flooding; treating and managing surface water runoff in flood events before releasing it into the Holgate Beck.

## 3.2 ECOLOGY STRATEGY

The York Central site supports a diverse range of invertebrates, breeding birds and bats. In addition, the site contains the Millennium Green, part designated as a Site of Importance for Nature Conservation (SINC). The future development of the site should ensure key habitats are retained, or if lost, recreated. This is essential in maintaining site biodiversity and function of the wider green infrastructure resource in York. It is also recommended that site enhancement for biodiversity is embedded within the development.

Recommended actions to safeguard and enhance biodiversity include:

The dominant habitat type on site is brownfield, which supports County important assemblages of invertebrates. Mitigation for the loss of brownfield and the mosaic habitats associated with this is required. Other habitat types identified on site which support biodiversity include semi-improved grassland, trees and scrub.

In developing proposals for its site the Museum will take account of existing ecology and where possible enhance its site for biodiversity.

**New areas shall include the creation of habitat mosaics e.g. scrub fringe/bare ground/grassland interface for invertebrates, woodland/scrub/grassland for bats and birds and a combination of all these features within wetland habitats.**

**Railway ballast that is currently on site shall be incorporated into habitat areas to replicate different types of bare ground habitats.** Specifically, this can be utilised alongside the proposed and retained railway in the Central Park.

**All planting must be undertaken at appropriate times of year to ensure successful establishment and growth.**

**A habitat management plan must be provided to ensure the success and efficacy of mitigation. This plan shall also include a monitoring period of at least three years.**

**The use of lighting in habitat areas shall be limited to areas where it is essential for safety, security or a requirement for movement of vehicles.**



Fig.53 Biodiversity Strategy

Within the habitat areas lights should be designed to be directed at the ground or low level lighting considered as an alternative to traditional street light design. Trees, scrub and hedgerows must not be permanently lit for aesthetic purposes as this reduces the suitability for roosting, foraging or commuting bats and birds.

Lights should be designed to be directed at the ground or low level lighting considered as an alternative to traditional street light design. Trees, scrub and hedgerows must not be lit for aesthetic purposes as this reduces the suitability for roosting, foraging or commuting bats and birds.

It is strongly encouraged that all species selected for planting be native and of local provenance. Any non-native species utilised should when possible provide a nectar resource for invertebrates. Flowering plants should provide sequential foraging resources throughout the year.

Railway ballast that is currently on site is strongly encouraged to be incorporated into habitat areas to replicate different types of bare ground habitats. Specifically, this can be utilised alongside the proposed railway in the Central Park.

Bird nest boxes and bat boxes shall be considered on appropriate trees or buildings.

Consultation must be sought from an appropriately experienced ecologist to support the integration of ecological mitigation within the Site design.

### 3.2.1 Millennium Green

The SINC area of Millennium Green is currently managed for its species rich grassland by the Millennium Green Trust. Following development of York Central, it is important to try to ensure that this area is managed appropriately to maintain existing grassland habitats.

All habitats lost during development of the site access road will be replaced at a 1:1 ratio and all species selected will be native and of local provenance. Management of invasive species is a key objective for enhancing biodiversity within Millennium Green.

### 3.2.2 Wetland Garden

**The creation of a Wetland Garden area (refer to Fig. 75) shall support both terrestrial and aquatic species.**

Key considerations include: the source and permanence of water, drawdown zones, management of water quality and pollution and suitable planting within areas of the wetland. The Wetland Garden will require a 10 yr management strategy and consideration for public access.

### 3.2.3 Stream Garden

**The Stream Garden (refer to Fig. 75) shall support both terrestrial and aquatic species. An appropriate management strategy will be necessary for management of vegetation.**

### 3.3 SUSTAINABLE URBAN DRAINAGE STRATEGY

Implementing Sustainable Urban Drainage Systems (SUDS) will contribute significantly to the sustainability of the development and improve resilience to flooding risk by managing surface water runoff in ways that mimic natural processes. The Central Park provides a large surface area that can be used for the retention of water in extreme rainfall scenarios. In a high rainfall event, excess water can be held in SUDS channels and a pond before being released into the Holgate Beck.

#### 3.3.1 SUDS - swales

The following principles must be observed when designing the SUDS:

The SUDS shall work alongside the below ground drainage system to accommodate storm events up to a 1-in-10 return period within the channels and pond.

The Reed Garden shall act as a tidal pond that responds to seasonal rainfall and provides a focus for wildlife within a water garden habitat.

The Reed Garden shall be planted with specially selected plant species used to filter water.

The SUDS may be divided in 3 parts; Boulevard Swale, Central Park Swale and Reed Gardens (pond). Water flows horizontally and is gradually treated before being discharged to Holgate Beck.

It is strongly encouraged that the SUDS system on the Boulevard have a continuous row of trees and its character be formal with built edges providing a separation between the spill-out areas, pedestrian and cycle routes.

It is strongly encouraged that the Central Park swale provide a natural barrier to the National Railway Museum's train track and its edges planted with marginal and aquatic plants.

It is strongly encouraged that the SUDS have permanent water in the Central Park. The water should be mechanically circulated to allow oxygenation and prevent proliferation of algae.

The design shall aspire to implement the best practice guidance set out in CIRIA C753 The SuDS Manual.

The National Railway Museum will investigate ways to improve resilience to flooding risk as it develops its proposals. Analysis will be undertaken to ensure any surface water runoff created does not increase flood risk.

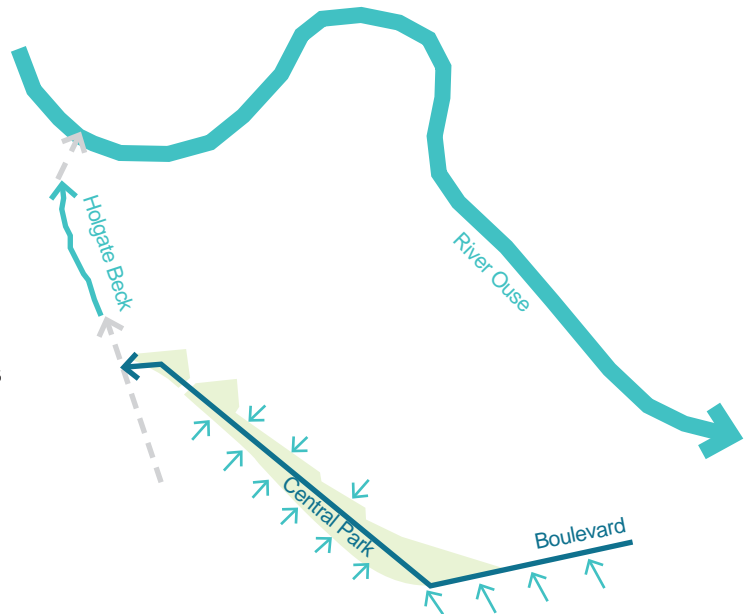

Fig.54 York Central SUDS strategy

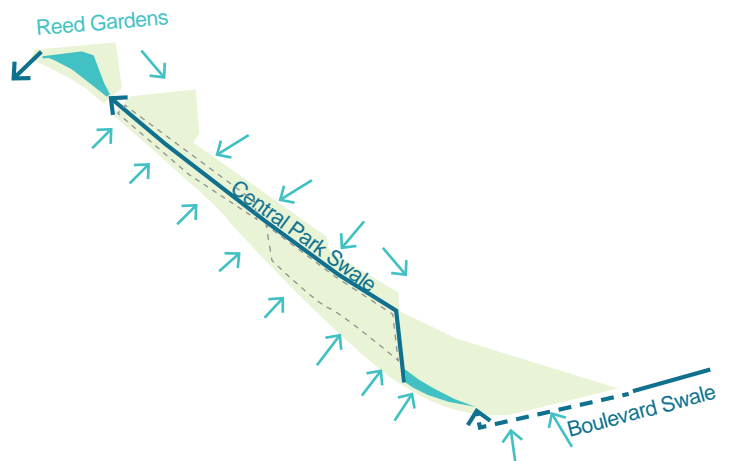

Fig.55 SUDS strategy: 1-in-10 years flood event

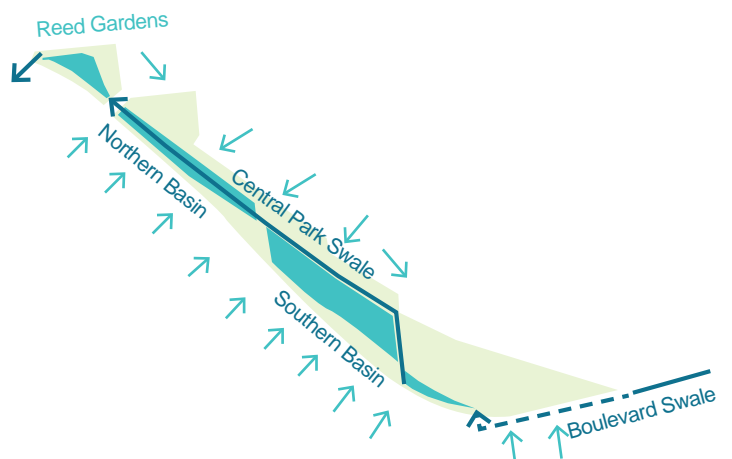

Fig.56 SUDS strategy: 1-in-30 and 1-in-100 years flood event



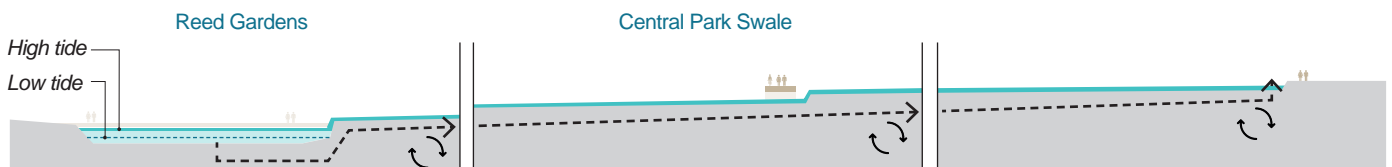

Fig.57 SUDS strategy - Surface water run-off flows through a system of linear swales into the Reed Gardens pond and is mechanically re-circulated to allow oxygenation and prevent proliferation of algae. In a high rainfall event, excess water can be held in the SUDS before being released into the Holgate Beck.



Fig.58 Central Park Swale character precedent



Fig.59 Boulevard Swale character precedent

---

### 3.3.2 North and South basins (dry SUDS)

The following principles must be observed when designing the north and south basins:

**The dry SUDS shall be designed to accommodate excess surface water from storm events between a 1-in-10 and 1-in-100 year return period, with allowance made for the impacts of potential climate change.**

The North basin shall be planted with a woodland with suitable species providing a functional and ecological benefit. Planting in the proximity of the railway link from the National Railway Museum to the National Rail Network shall be in accordance with the principles agreed with the National Railway Museum.

The South basin shall be an open lawn to allow for its use as an informal recreation area when not flooded.

The design shall aspire to implement the best practice guidance set out in CIRIA C753 The SuDS Manual.



**Fig.60** Pedestrian circulation routes through the retention basins in a non-flood event



**Fig.61** Retention basin levels are to be designed so as to ensure primary pedestrian circulation routes are not compromised in a flood event

## 3.4 PUBLIC ART STRATEGY

York Central's new public realm presents a range of opportunities for public art in all its forms; from physically integrated artworks to ephemeral digital projections and temporary installations. Works of public art that are strategically sited and create a sense of place will encourage a sense of ownership and respect from residents and visitors.

### 3.4.1 Public art strategy

**Public art shall be site specific and culturally relevant to York and those that live in, work in or visit York Central; adding to the understanding of the place, its past, and cultural fabric.**

Artworks should be inspired by the site's pre-rail and railway heritage; and the skill, craft and mechanical production associated with this, are to be encouraged.

Opportunities for artwork that has a minimal impact on the environment and helps to express the site's environmental narrative and function are to be identified.

Art themes that are subtly integrated within the design of a place and its materiality and provide an interpretive role in telling the site's history are encouraged.

A wide range of public art media is to be explored to identify the most appropriate and responsive designs for each site.

These spaces should also facilitate community events and performances.

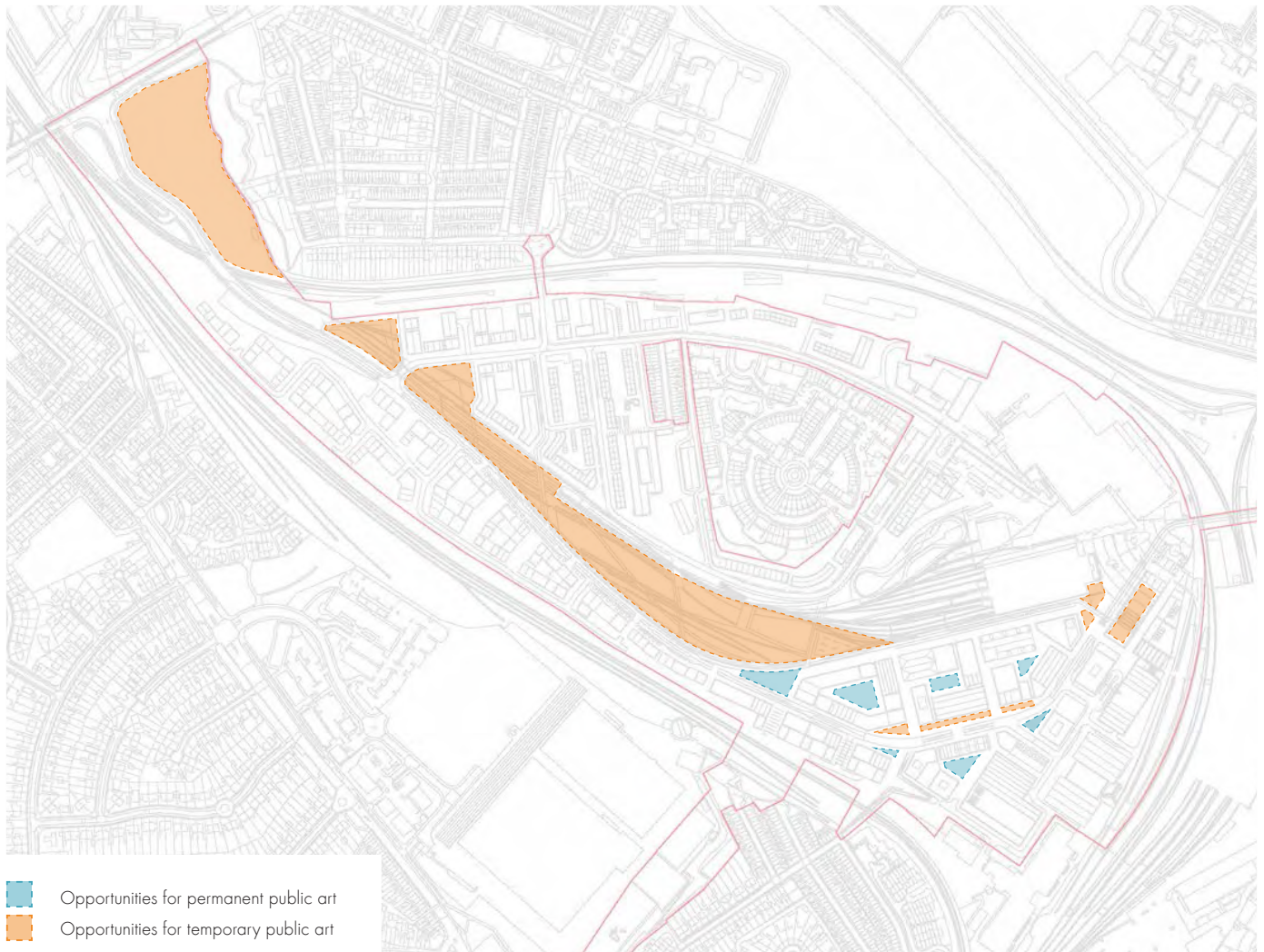

Fig.62 Map showing possible locations for public art based on the illustrative scheme (indicative only)



Fig.63 Public sculpture (Calligraphie Ferroviaire, Sten and François)



Fig.64 'Yarn bombing' (Crocheted Locomotive, Olek)



Fig.65 Public sculpture using re-purposed rails (Intersection, M. Passmore)



Fig.66 Temporary light installation (Waterlicht, Daan Roosegaarde)



Fig.67 Illuminated arches (Saint Blaise Square, Bradford Council)



Fig.68 Artwork integrated within paving design (Subway Map, Françoise Schein)

### 3.5 RECREATION AND PLAY STRATEGY

Recreation and play will be essential to the social, cultural and economic well-being of the York Central community. The site’s railway heritage offers a source of inspiration for innovative play spaces that contribute to York Central’s unique sense of place as well as encouraging healthy lifestyles. Play and recreation are integral to the urban fabric of the York Central development with leisure opportunities to be provided for all age groups.

#### 3.5.1 Hierarchy of play provision

The following hierarchy of provision of play and sports areas is recommended:

- LAP - Local Areas for Play or ‘door-step’ spaces - for play and informal recreation; close to home, engaging play features for young children under 5; catchment 100m.
- LEAP - Local Equipped, or local landscaped, Areas for Play - for play and informal recreation; landscaped space with play equipment so that children aged 0 to 11 can play and be physically active; catchment 400m.
- NEAP - Neighbourhood Equipped Areas for Play - for play and informal recreation; varied natural space with secluded and open areas, landscaping and equipment so that children aged 0 to 18 can play and be physically active; catchment 800m. (See fig. Recreation and Play Strategy)

The indicative location and catchment areas of the above typologies of play (LAP, LEAP, NEAP) are identified on the diagram below.



Fig.69 Play space character precedent

- LAP - Local areas for play or “door-step” spaces - for play and informal recreation; 0-5 years
- LEAP - Local equipped, or local landscaped, areas for play and informal recreation; 0-11 years
- NEAP - Neighbourhood equipped areas for play and informal recreation; 0-18 years
- Informal sport area

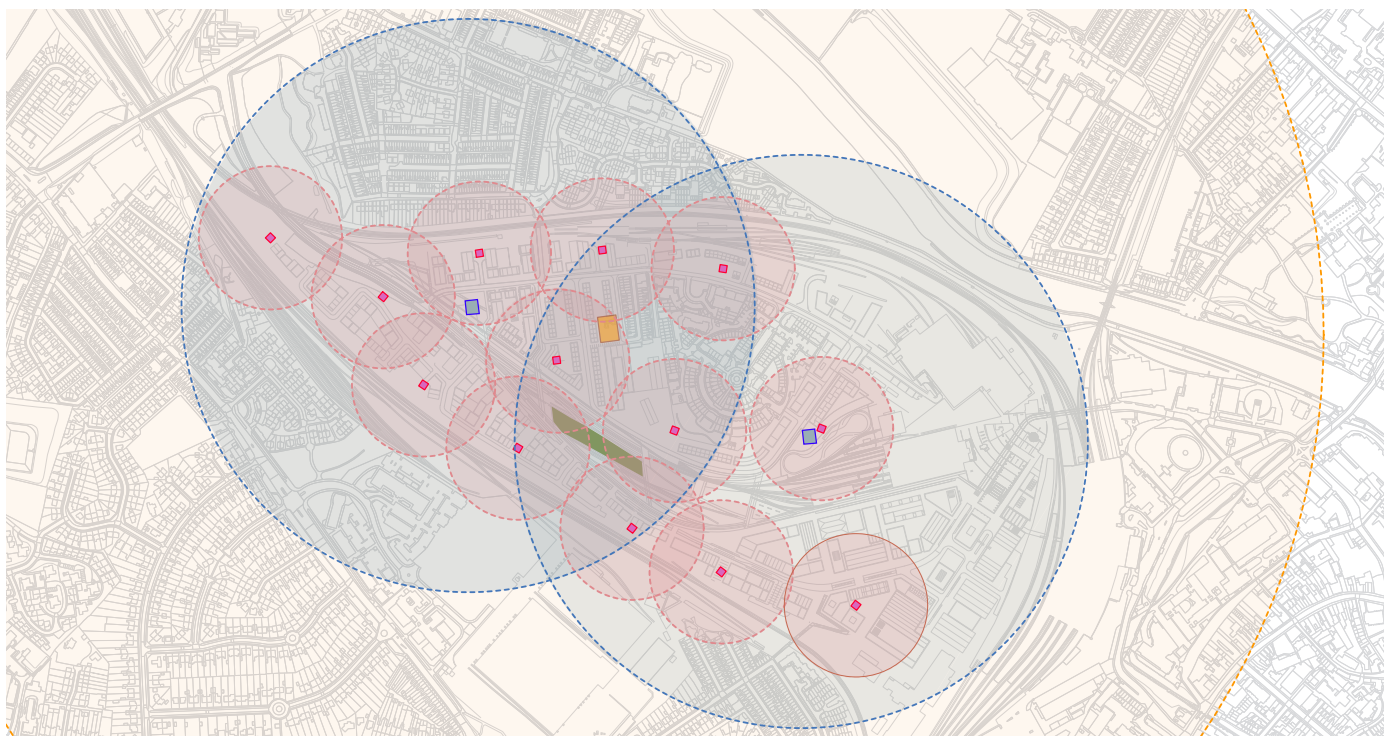

Fig.70 Recreation and Play Strategy (indicative only)

An open lawn area shall be provided within the Central Park for informal sport or recreation activities for all ages.

Fitness trail - the main routes of the Central Park should include outdoor gym facilities and circular routes created for running, walking and cycling.

Innovative play elements which evoke the railway heritage of the site to create stimulating environments for play are encouraged.

Where possible, play areas should be integrated within the topography of the landscape.

Contributions towards sports and play facilities is likely to be required as on-site provision is often not possible due to area constraints.

**The design shall aspire to implement the best practice guidance set out in Play England's "Design for Play: A Guide for Creating Successful Play Spaces (2008) and "Planning and Design for Outdoor Sport and Play" published by NPFA.**

Proposals for the National Railway Museum site are intended to increase the number of visitors and residents using and enjoying the site. Increasing visitors dwell time is a core aspiration. Plans will consider the role of play for recreation and for learning.<sup>4</sup>

The diagram below describes the indicative location of the fitness circuit and associated fitness stations which are to offer a range of different sporting challenges for different levels of ability.



Fig.71 Play space character precedent



Fig.72 Fitness trail character precedent

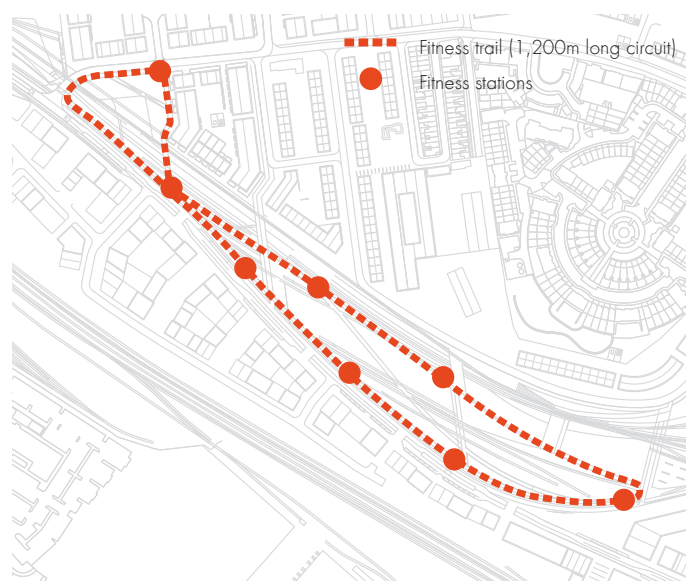

Fig.73 Central Park Fitness Trail (indicative only)

## 3.6 CENTRAL PARK

The Central Park will be a major asset to York and will encourage use from the local community, visitors, and those that live and work in the surrounding area. The park's character develops along its length and is key to connecting Millennium Green and the River Ouse Corridor with the city centre to the east, as well as enabling water management and opportunities for biodiversity and leisure use.

### 3.6.1 Millennium Green

The following principles shall be observed when considering the landscape treatment of Millennium Green:

Protect and enhance the existing wetland habitat through riparian regeneration and additional tree planting, enhancing the area's existing natural beauty and enriching its ecological value.

Retain the existing memorial oak and mosaic.

Where possible, slopes are to comprise grades of less than 1:3. Paths are to comprise grades of less than 1:20.



Fig.74 Millennium Green character precedent



Fig.75 Central Park Key Plan



### 3.6.2 Reed Garden

The following principles shall be observed when designing the Reed Garden:

To be planted with species of a wet woodland character appropriate to a wetland environment.

Contribute to the ecology and habitat zones identified in 3.2 “Ecology strategy”.

Function as part of a site wide natural water management system as per section in “3.3 Sustainable Urban Drainage strategy” on page 50.

Retain former railway tracks where possible and convert them to accessible footpaths. Provision shall be made for the relocation of tracks if required.

Encourage opportunities for interactivity and interpretive elements that help to express the site’s environmental narrative and function.

### 3.6.3 Stream Garden

The following principles shall be observed when designing the Stream Garden:

To be planted with species of a riparian woodland character appropriate to a river valley environment.

Embankments to have a maximum grade of 1:3 and paths of less than 1:20.

Contribute to the ecology and habitat zones identified in “3.2 Ecology” on page 46.

Retain former railway tracks where possible.

Function as part of a sitewide natural water management system as per section “3.3 Sustainable Urban Drainage strategy” on page 50.

Incorporate a community playspace.

Integrate bridges, accessible to all visitors, that cross the Stream Garden to link the development areas north and south of the Park. The heights of bridges are to be designed to ensure circulation routes are not compromised during flood events.



Fig.76 Reed Garden character precedent



Fig.77 Stream Garden character precedent



Fig.78 Central Lawn character precedent

### 3.6.4 Central Lawn

The following principles shall be observed when designing the Central Lawn: Provide spaces for both active informal play and quieter picnic areas; Embankments to have a maximum gradient of 1:4; Retain former railway tracks where possible; Function as part of a site wide natural water management system as per section "3.3 Sustainable Urban Drainage strategy" on page 50. The interface between the Central Lawn open space and steam train tracks is to comprise a swale and be designed so as to create a natural barrier protecting people from the steam train activity. Incorporate the National Railway Museum visitor train arrival platform and cafe.

### 3.6.5 Amphitheatre

The following principles shall be observed when designing the Amphitheatre: Provide spaces for both active informal play and quieter picnic areas. Provide a generous pedestrian and cycle connection under the National Railway Museum visitor train ride bridge. The passageway under the steam train ride shall be well lit with a clear line of sight from access to egress. There must be an 'open mouth' splay to the entranceways. Provide sloped lawns, offering views of the park and steam train ride, with a maximum gradient of 1:20. Embankments shall be planted with species of a wildflower meadow character adhering to the ecology and habitat zones identified in section 3.2 "Ecology strategy".



Fig.80 Embankments planting character



Fig.81 Amphitheatre character precedent



Fig.79 Areas of railway tracks to be retained and where applicable, filled with ballast and planted

Fig.82 Gravel Garden character precedent

### 3.6.6 Gravel Garden

The following principles should be observed when designing the Gravel Garden: Retain former railway tracks where possible, to be filled with ballast and planted with native species adhering to the ecology and habitat zones identified in section 3.2 “Ecology strategy”. Protect brownfield habitat zones where possible as identified in section 3.2 “Ecology strategy”.

The Gravel Garden shall incorporate a SUDS water feature of a formal character at its east entrance.

### 3.6.7 Garden Plaza

The following principles should be observed when designing the Garden Plaza: Provide a predominantly hardscaped civic space that serves as a main eastern entry point to the Central Park. Tree planting shall be provided in a formal arrangement. Provide seating and rest spaces.

### 3.6.8 National Railway Museum Yard

The Museum’s ambitions are to significantly enhance this area by removing older temporary buildings, creating more open space and increasing permeability and accessibility. Improving the setting and the views of the western elevation of the listed Station Hall is an intrinsic component of the emerging Masterplan vision.

It is strongly encouraged that the following principles be observed when designing the National Railway Museum Yard: Provide a predominantly softscaped open space that offers flexibility of use and can host events such as concerts and open air cinema. Utilise trees and ornamental planting to provide shelter, shade and seasonal interest. Retain and enhance the miniature railway train experience. Retain existing railway tracks where possible, to be filled with ballast and planted with species adhering to the ecology and habitat zones identified in 3.2 “Ecology strategy”.

Incorporate a playspace.

Incorporate the visitor train ride departure platform.



Fig.83 Garden Plaza character precedent



Fig.84 Museum South Yard character precedent



Fig.85 National Railway Museum South Yard gate precedent

### 3.6.9 National Railway Museum Visitor Train Railway Link

The following principles shall be observed when designing the National Railway Museum visitor train route interface and rail link through the Central Park:

All interfaces between the public highway (including pedestrian/cycle routes) and the rail link, must be in accordance with the appropriate legislation and design standards.

Crossing points shall be designed so as to always ensure the safety of crossing pedestrians, cyclists and vehicles, with appropriate fencing and barriers to be provided.

The visitor train ride shall be fenced for the safety and security of the public and the line.

Crossings points are to comprise level transitions with a good quality accessible crossing or an underpass providing connection through to a potential amphitheatre.

Fencing shall be high quality, integrated within the landscape design. The visual impact of fencing to be minimised through the design of land form and planting.

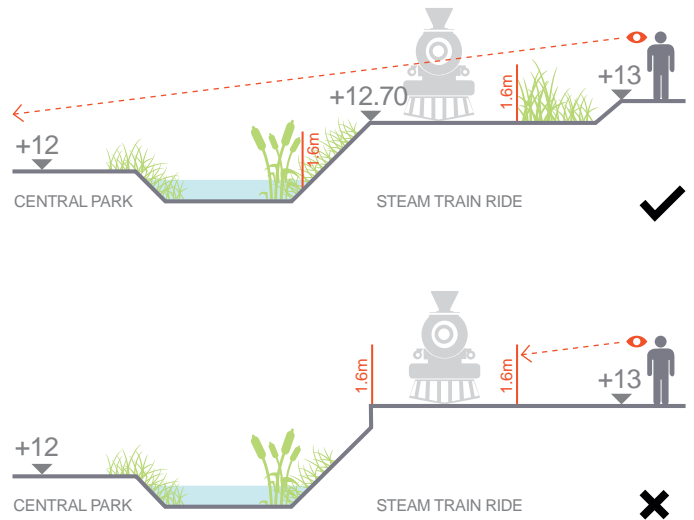

Fig.86 Landform and planting are to be designed so as to minimise the visual impact of safety barriers (all levels are indicative only)

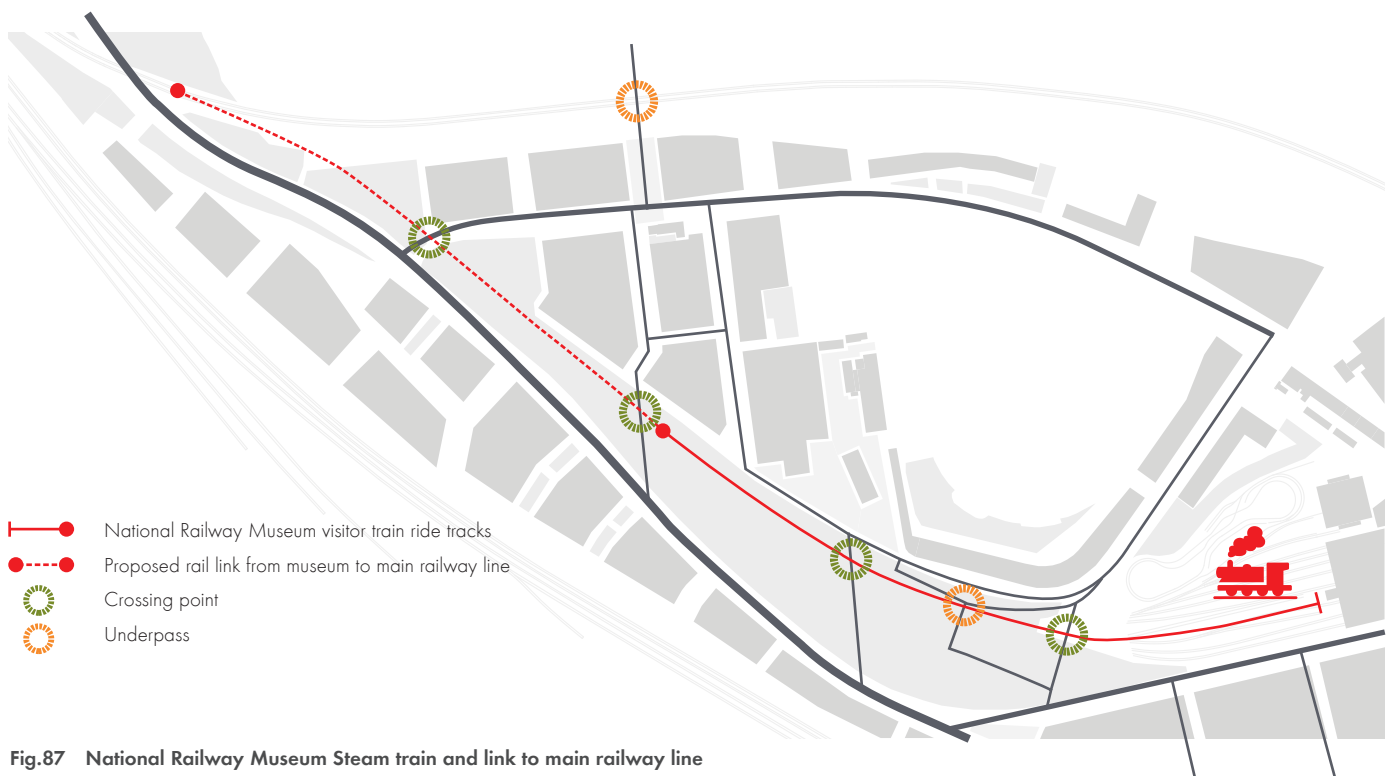

Fig.87 National Railway Museum Steam train and link to main railway line

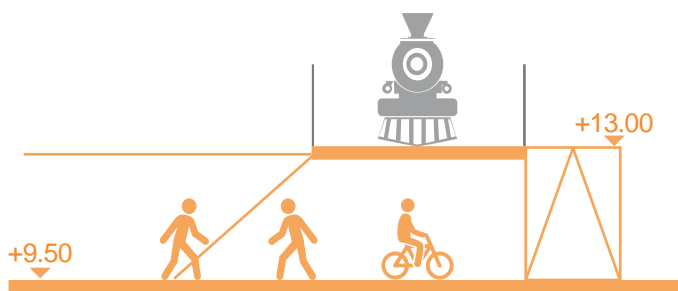

Fig.88 Preferred: pedestrian-friendly railway underpass (all levels are indicative only)



Fig.91 Olympic Park, Stratford, London

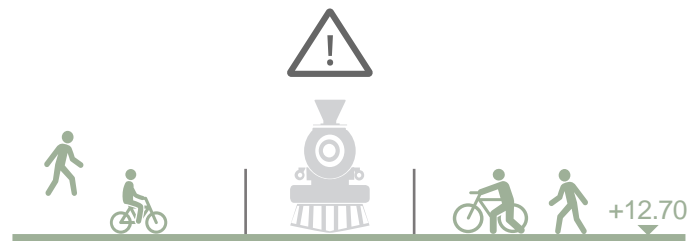

Fig.89 Acceptable: At grade railway crossing (all levels are indicative only)



Fig.92 Rail crossing Der Zollverein Park, Germany

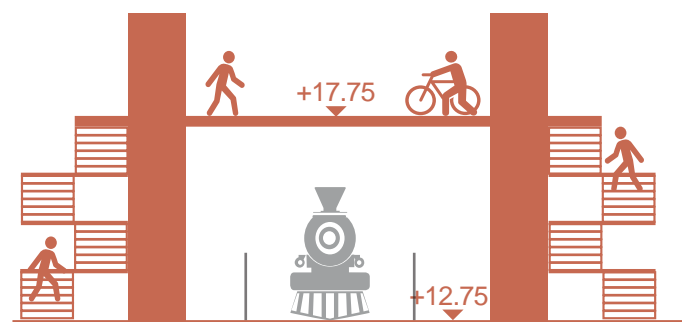

Fig.90 Bridge crossing over tracks. Not preferred



Fig.93 Example of inappropriate pedestrian crossing

## 3.7 NEW SQUARE

The New Square will provide a city-scale space at the threshold between the core city centre and York Central. The square should be understood as one integrated urban space, but composed of two halves – Station Gateway to the south, and Museum Gateway to the north. These will have different identities and characteristics, reflecting the square's multiple roles as a space for arrival, gathering and activity for the city.

### 3.7.1 Museum Gateway

The Museum's proposals for new buildings adjacent to Museum Gateway Square will be evolved to give high quality enclosure to the public realm and maximise the synergies between outdoor space use and the use of gallery spaces.

The following principles shall be observed when designing the Museum Gateway:

Provide a compelling city-scale open space which is not just the 'front door' to the National Railway Museum but also a key public space within York Central.

Highlight the history and railway heritage of the site in the design of the square.

Resolve the level changes between Marble Arch, the Museum and Station entrances to provide useful, flexible surfaces for events and social interaction.

Provide opportunities for cafe seating spill-out spaces.

Provide access to East Coast Mainline Rail from the Museum Gateway.

Retain the existing entrance to the Goods Station.

Utilise tree planting alongside the road with a reference to the former Goods Station enclosure.

Terrorism defences shall be considered when designing the Museum Gateway and incorporated where possible.

Allow views of the Station gable ends and York Minster beyond, see Chapter 02: Heights, Levels and Massing

Provide lighting and security measures to ensure



Fig.94 Museum Gateway character precedent

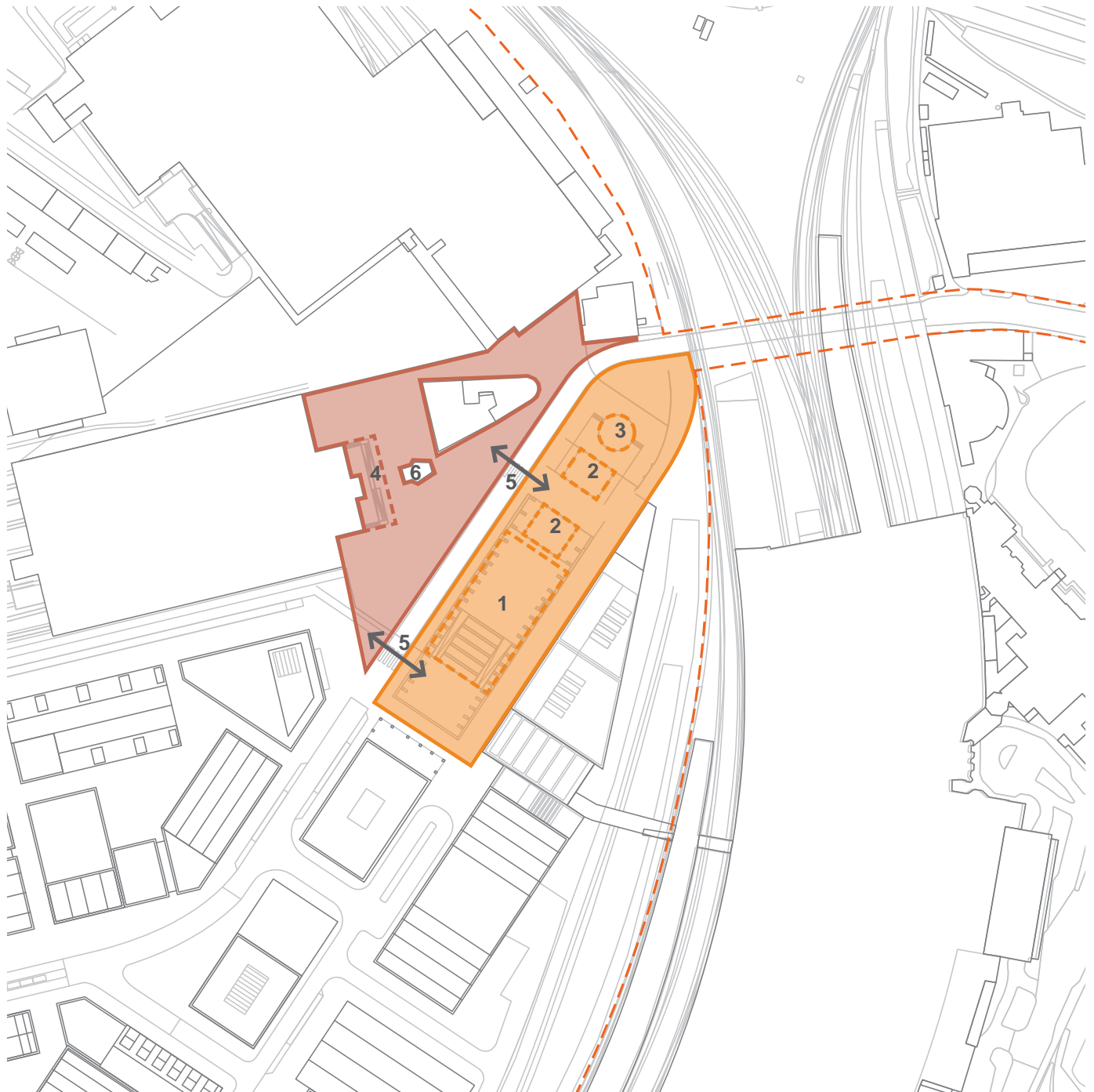

Fig.95 New Square Key Plan

- Museum Gateway
- Station Gateway
- 1. Coal Drops Event Space
- 2. Water Feature
- 3. Cafe Pavilion
- 4. Cafe Spill-Out Space
- 5. Pedestrian Crossing
- 6. Retained Weigh Station

---

### 3.7.2 Station Gateway

The following principles shall be observed when designing the Station Gateway:

Create a 'front door' to York Central by designing a western station entrance well-integrated into the emerging new district.

Ensure that the western station access has a legible and visible presence on Museum Square.

In addition to a 'front door' on Museum Gateway, orient the station entrance to acknowledge the new mixed-use commercial district to the south.

Provide the required functional amenities (car/cycle parking, bus, passenger drop-offs and taxi drop-offs etc.) which prioritise pedestrian comfort and quality and provide full accessibility for cyclists.

Utilise the level change of the Coal Drops to provide a flat, flexible and sheltered public space that expresses the site's railway heritage, while ensuring accessible routes to and through the Coal Drops for all.

Design for flexibility of use to provide a Station Gateway that can accommodate markets, concerts and other events.

Water features are encouraged. These could be designed to be filled with water to create reflective water pools or drained so that the space can be utilised for other activities and events.

Areas of soft landscaping may be used. Trees and ornamental planting should be utilised to provide shelter, shade and seasonal interest to the Station Gateway and provide a sense of enclosure to the Coal Drops.

Terrorism defences should be considered when designing the Station gateway and incorporated where possible.

Provide lighting and security measures to ensure the safety of all users.



Fig.96 Station Gateway character precedent



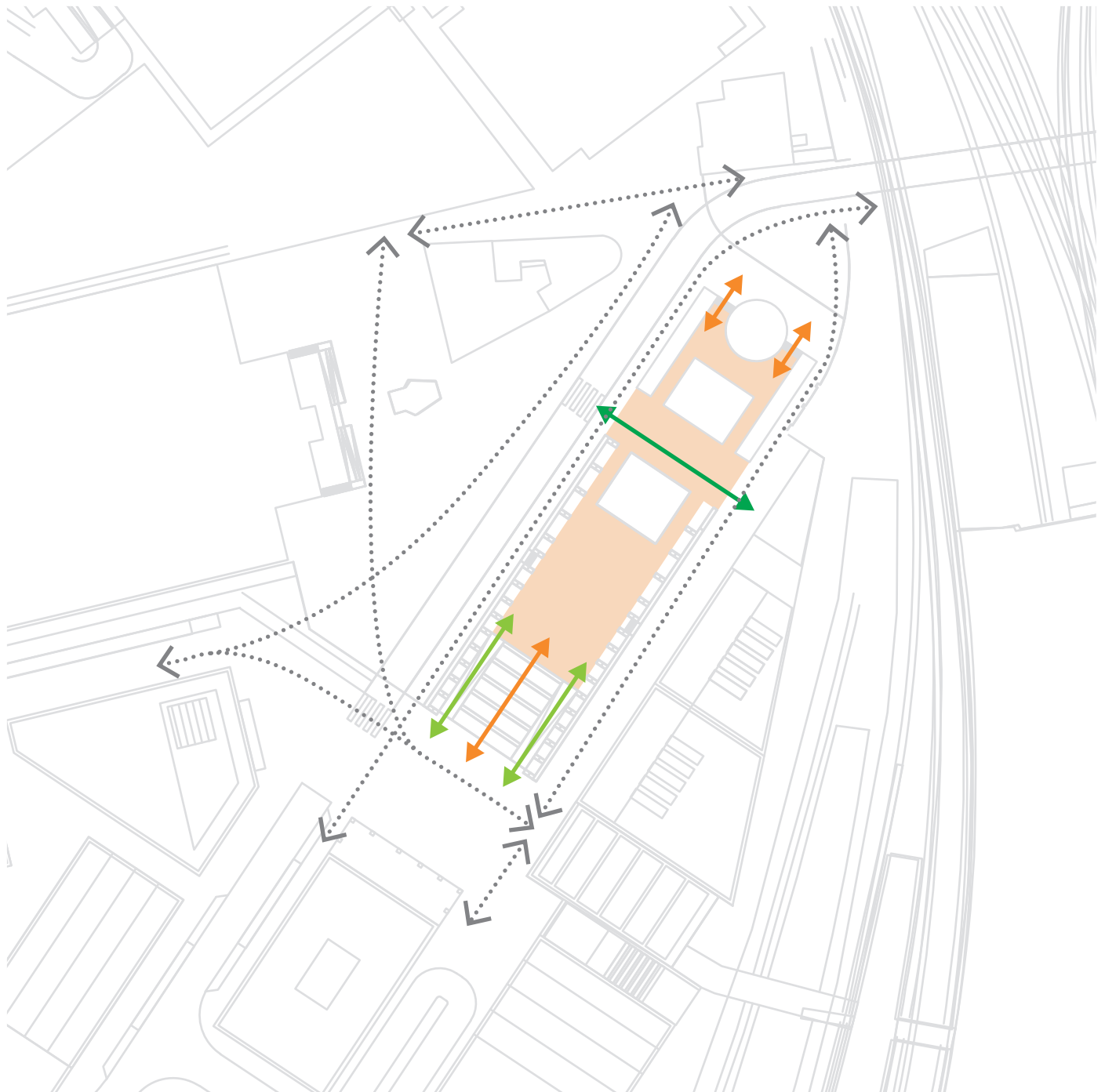



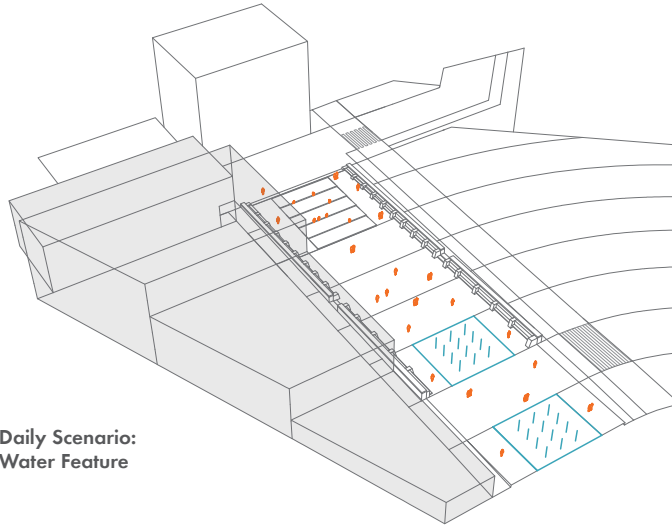
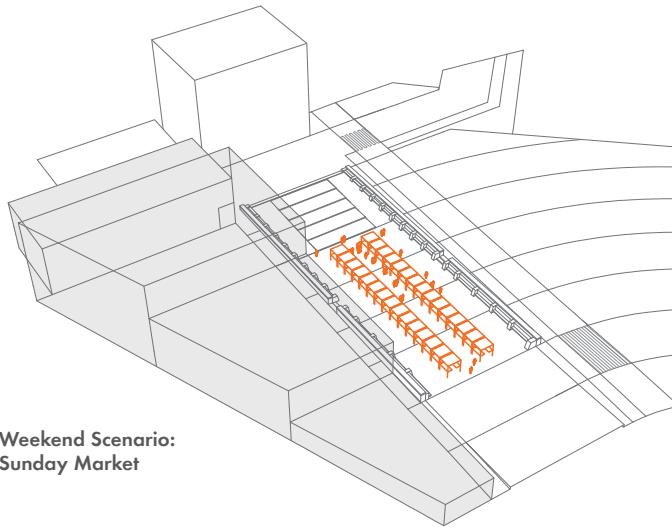

Fig.97 Access to Coal Drops

-  Level access
-  1:20 ramp access
-  Stepped access
-  Main circulation routes



Daily Scenario:  
Water Feature



Weekend Scenario:  
Sunday Market

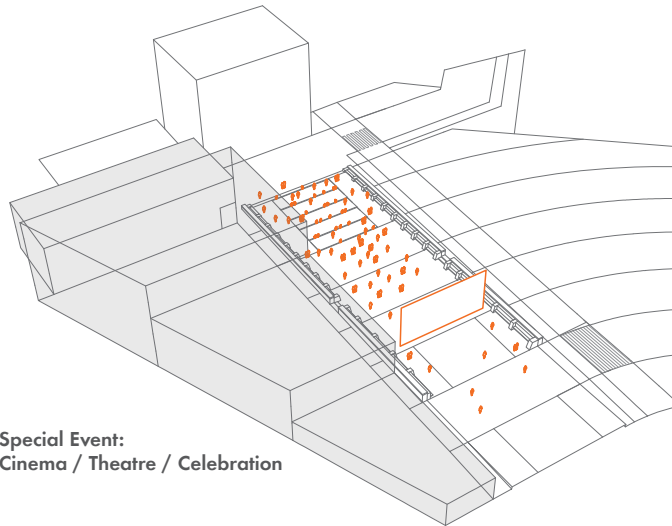

Special Event:  
Cinema / Theatre / Celebration

Fig.98 The Coal Drops are to provide a flat space offering flexibility of use and accommodating a variety of activities and events, such as water features, markets, and concerts.



Fig.99 Granary Square, London



Fig.101 Market events



Fig.100 Festival events in public space

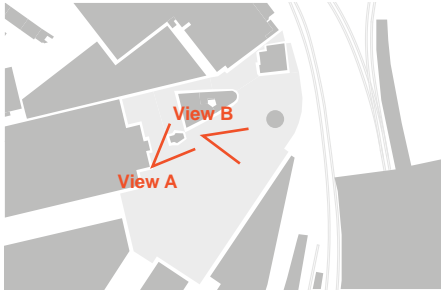

The Museum Gateway provides a public ‘front door’ to the National Railway Museum. The arrival space, framed by the Museum’s Goods Station Building, Great Hall Building and new Entrance Gallery, faces south and offers views towards the arches of the Railway Station, the movement of trains and the York Minster beyond.

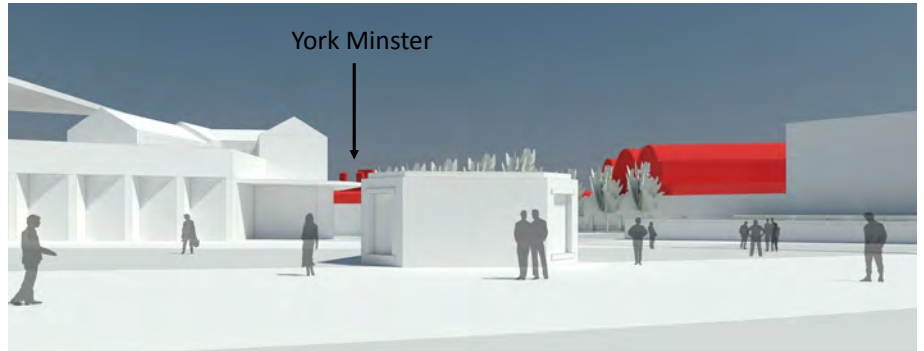

**Fig.102 View A** - The New Square design is to allow views of the station gable ends and York Minster beyond.



**Fig.103 View B**: The New Square design is to allow views of the station gable ends and York Minster beyond.

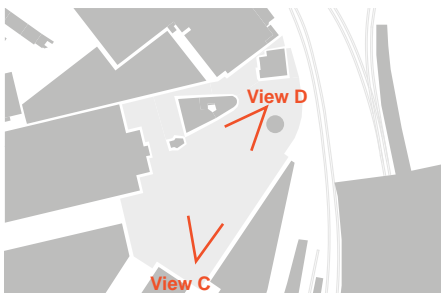

Shallow ramps provide disabled access to both the north and south ends of the Coal Drops with a ramp and shallow terraces providing an amphitheatre for events. A cafe/kiosk at the northern end frames the space adjacent to Marble Arch before arrival into the Station Gateway. In front of the Cafe two water features, drained when the space is utilised for events, create reflective pools and pull light into the space.



**Fig.104 View C**: Entry to the Coal Drops from the south is to be provided with steps and 1:20 grade ramps



**Fig.105 View D**: Accessible routes to and through the Coal Drops are to be provided

## 3.8 STATION QUARTER

Station Quarter, a vibrant environment for work, residential and retail with a fine grain communal character, will be defined by its high quality public spaces and streets. Hudson and Wilton Place form focal points to the public life within the Station Quarter and the courtyards of the Cinder Yards, framed by the building blocks, provide quiet break out spaces for the adjacent homes and offices, offering opportunities for socialising and relaxing.

### STATION QUARTER

- 14 George Square
- 15 Cinder Yards
- 17 Wilton Place (a), Cinder Street (b) and Hudson Place (c)
- 18 Station Gateway



### 3.8.1 George Square

George Square forms the westernmost point of the Station Quarter. It is a pedestrianised space which addresses Park Plaza and the Gravel Gardens.

The following principles shall be observed when designing George Square:

Opportunities for public art that conceptually engage with and strengthen the sense of place is encouraged, refer to section “3.4 Public Art Strategy” on page 54. Lighting and water can also engage and strengthen a sense of place.

Utilise trees and ornamental planting to provide shelter, shade and seasonal interest.

Public bench seating, and cafe/restaurant seating shall be provided as appropriate.

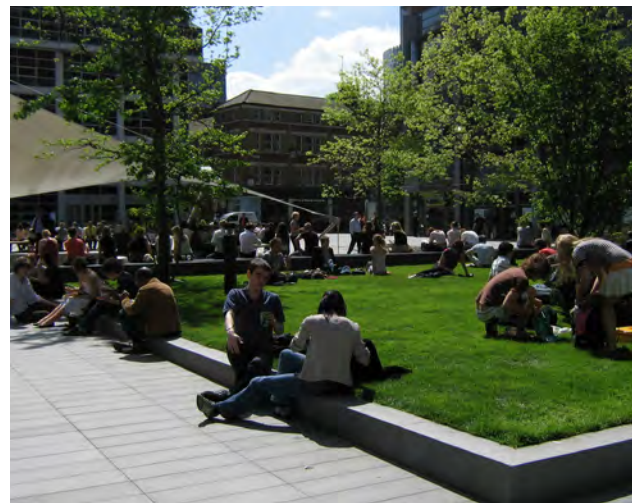

Fig.106 George Square precedent, Bishop's Gate Square, London

### 3.8.2 Hudson Place and Wilton Place

The following principles shall be observed when designing Hudson Place and Wilton Place:

Opportunities for public art that conceptually engage with and strengthen the sense of place is encouraged, refer to section “3.4 Public Art Strategy” on page 54. Lighting and water can also engage and strengthen a sense of place.

Pedestrian movement shall be prioritised.

Utilise trees and ornamental planting to provide shelter, shade and seasonal interest to the courtyard spaces.

Public bench seating, and cafe/restaurant seating shall be provided as appropriate.



Fig.107 Hudson Place/Wilton Place character precedent

### 3.8.3 Cinder Yards

The following principles shall be observed when designing the Cinder Yards:

The Cinder Yards should be considered as ‘urban rooms’ that provide quiet and protected break out spaces for workers and residents of York Central.

The Cinder Yards and pedestrian connections (snickets) through should draw inspiration from York’s historic yards and streets/alleys, such as the Shambles and Shambles Market.

They shall facilitate ease of pedestrian movement and promote permeability between Hudson Boulevard and Cinder Street.

Trees and ornamental planting shall be used to provide shelter, shade and seasonal interest to the courtyard spaces.

Public bench seating, and cafe/restaurant seating shall be provided as appropriate.



Fig.108 Cinder Yards character precedent, Clerkenwell, London

### 3.9 FOUNDRY QUARTER

The Foundry Quarter encloses public open spaces of Foundry Square with Foundry Yard; community oriented focal points that provide settings for a diverse and evolving range of uses.

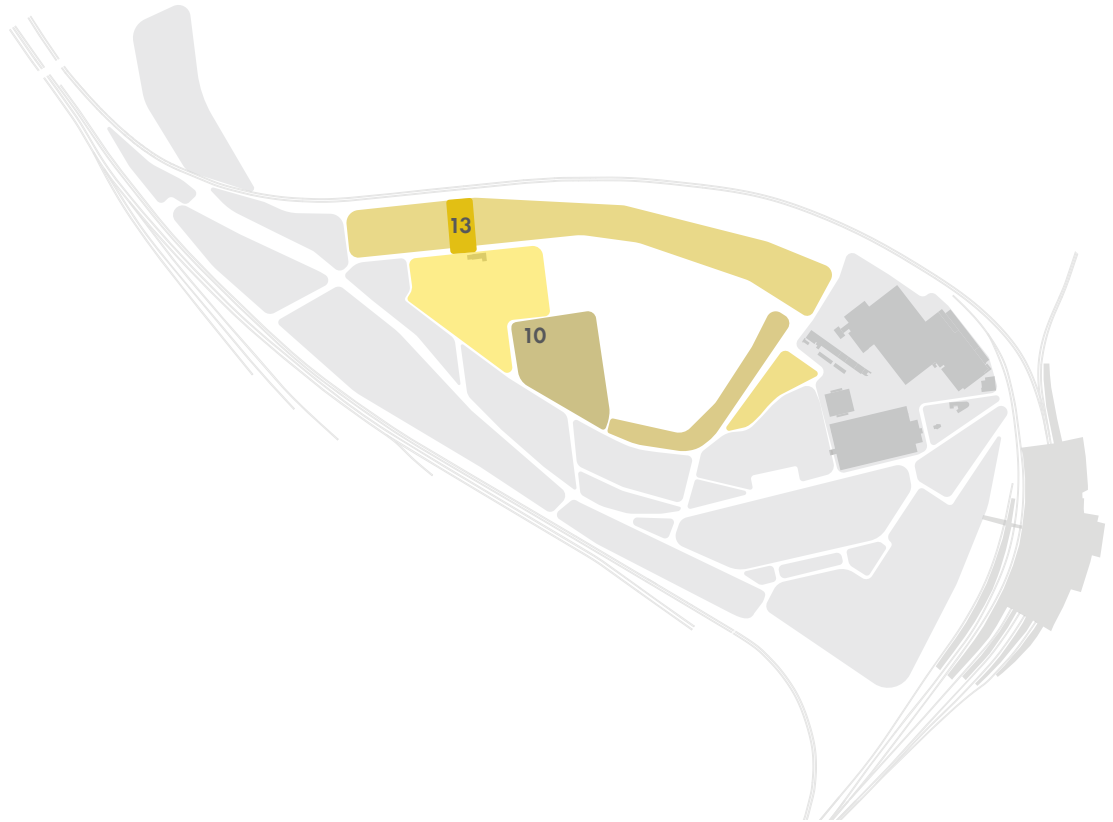

#### FOUNDRY QUARTER

- 10 Foundry Yard
- 13 Foundry Square

#### 3.9.1 Foundry Square

The Foundry Square shall provide a northern gateway space into the Foundry Quarter. The following principles shall be observed when designing Foundry Square:

Integrate the design of Leeman Road West and the junction with Park Street within the Square design

Encourage reduced vehicular traffic speed through traffic calming measures, and promote pedestrian and cyclist connectivity through the incorporation of crossing points in the form of dropped kerbs or raised vehicle routes, etc.

Utilise trees and ornamental planting to provide shelter, shade and seasonal interest.

Provide a spill out area in front of the existing building on Foundry Square.



Fig.109 Foundry Square character precedent

### 3.9.2 Foundry Yard

#### The following principles shall be observed when designing the Foundry Yard:

Provide a simple and flexible landscape design comprising predominantly hardscaped spaces with strategic tree planting to provide shade, seasonal interest, and 'soften' the character.

Utilise a design language and material palette that reflects the site's railway heritage, drawing on the unique character of the Foundry Buildings and their historical use to inform a design response.

Provide a community oriented setting for social gatherings, markets, cultural activities and other pop-up events focussed around the existing Foundry Buildings.

Provide a flexible and responsive space; the character and use should adapt to the changing needs of those who live and work in the Foundry Quarter.

Look for opportunities to incorporate reclaimed materials from the York Central site that reflect its former industrial use.



Fig.110 Foundry Square character precedent



Fig.111 Foundry Yard character precedent



Fig.112 Foundry Yard character precedent

## 3.10 SITE PERIMETER

The York Central site has a unique perimeter condition. Many Development Zones interface directly with railway corridors and the National Railway Museum. How the site perimeter is treated will strongly influence the quality of York Central's living spaces and open space identity.

### 3.10.1 Site perimeter to railway

The following principles shall be observed when designing landscaping to the site perimeter:

A 'hard boundary' to the rail network and Network Rail operational land shall be provided. Suitable secure fencing to lineside boundaries shall be provided to prevent access to the rail network. Steel palisade fencing is to be avoided in favour of discreet mesh fencing. Fencing shall be integrated within the landscape design and obscured by planting and landform as much as possible.

All boundaries to railway and non-populated land shall be overlooked with active ground floor frontages and entrances to buildings/housing where possible. There shall be no defensible barriers over 1m (to enable overlooking).

Planted buffers in conformance with Network Rail guidelines shall be provided to reduce the visibility and noise of rail corridors as well as creating visually appealing views out to the site perimeter.

No deciduous trees or other trees and shrubs are permitted in locations where they may cause leaves to fall on to adjoining Network Rail operational land.

No trees are to be planted in locations where they might provide a means of scaling the boundary fence to Network Rail operational land or where trees will or be likely to cause damage to the boundary fence.

Vegetation is not permitted to encroach on to Network Rail operational land and all perimeter vegetation is to be managed in accordance with Railway Industry Group Standard GC/RT5202 "Vegetation, Managing the Risks".

No non-deciduous tree or trees are permitted to be planted unless such tree or trees is or are no closer to the nearest running railway line than 1.5 x the mature height of such tree or trees.

**Fences between York Central and adjacent the railway land shall confirm to the Network Rail Standard NR/L2/TRK/5100.**

**The fence type which shall be applied to the perimeter is a Mesh 2 Fence which corresponds to BS1722-14:2001**

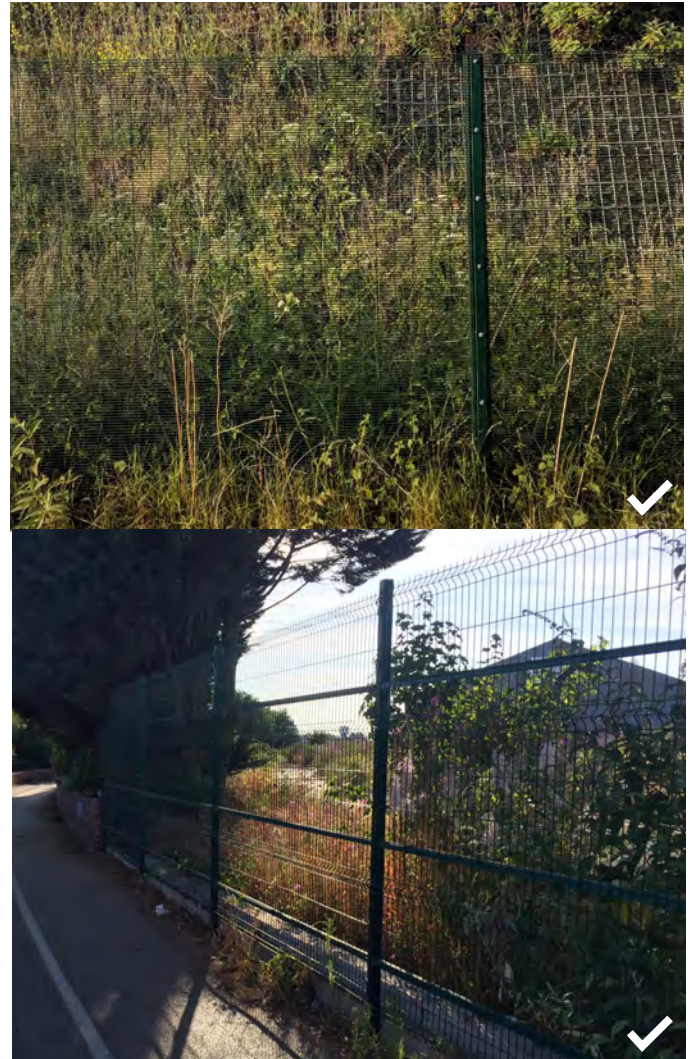

Fig.113 Discreet green mesh fencing blends into landscape.

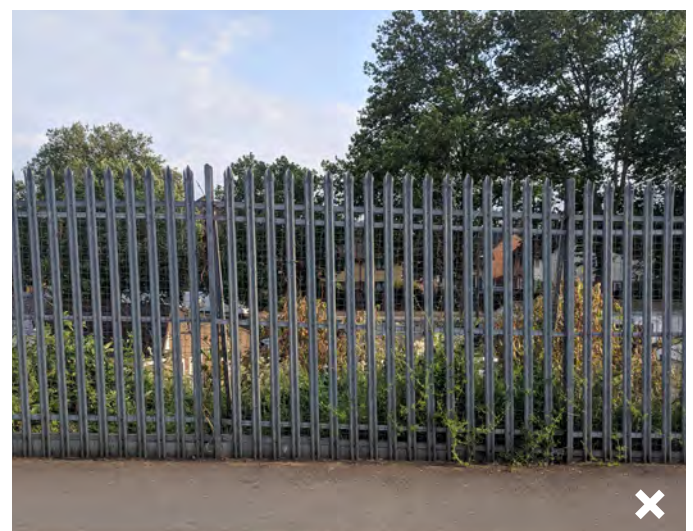

Fig.114 Palisade fencing will not be acceptable.



### 3.10.2 Perimeter with National Railway Museum

The Museum has an extensive boundary with York Central. Its emerging Masterplan gives the opportunity to review and improve its boundary treatment to enhance perception, safety and permeability.

Fencing that is integrated with the landscape proposals is strongly encouraged.

Use of appropriate industrial materials is strongly encouraged.

**The railing separating Hudson Boulevard from Museum South Yard shall be a secure, elegant parkside metal railing of a contemporary design.**



Fig.115 Example of possible boundary fence to National Railway Museum



Fig.116 Boundary fencing integrated with landscape proposals



## 4 STREETS

This section describes the intended nature of the streets and movement networks within York Central. It describes the hierarchy of streets; pedestrian, cycle and vehicular movement; play streets; parking strategies; junction design; and defines the principles for shared spaces; and how streets can be accessible to all.

## 4.1 STREET HIERARCHY

York Central will comprise a new network of streets and spaces which form the movement framework for the development. This network will link in with existing connections within the local context and facilitate key public transport interchanges. Pedestrian movement should be prioritised at all times and principles of accessible design considered throughout.

A series of primary, secondary and tertiary streets, pedestrian routes and cycle ways will provide the framework for a comprehensive public realm network. This network will allow the movement of people and vehicles across the different Development Zones and public spaces. A defined street hierarchy helps to develop legibility within the urban grain and contributes to the definition of character areas.

The design of the streets across the site should provide a strong sense of destination and enclosure with buildings, landscapes and landmarks organised to provide rich sequences of vistas as you move through the site and end-stops to vistas in more intimate streets. Tertiary streets are required for access only by residents/workers or service vehicles.

**All streets must be designed for the primacy of pedestrians and integrated into the communities that they move through.**

**Streets shall be designed for 20mph speed limit throughout the development.**

**The design of primary streets will be developed in conjunction with the adopting Highway Authority and will be subject to the Road Safety Audit process as detailed in the Design Manual for Roads and Bridges.**



Fig.117 Illustrative plan showing principles of access and streets network

## 4.2 STREET ADOPTION

---

It is envisaged that the majority of the street network shall be adopted as public highway and maintained by the CYC Highway Authority. The extent of adoption, and subsequent maintenance responsibilities, will be agreed between the landowner(s) and the Highway Authority and legal agreements entered into as needed.

Pedestrian streets can remain in private ownership with a presumption of open access and with certain rights of access granted, unless otherwise agreed between the landowner(s) and the Highway Authority.

All designated public open space shall be accessible via either the adopted highway of roads and footpaths where there are no access restrictions.

The following principles shall be applied when designing for adoption:

**Street palettes shall be designed to CYC adoption criteria as a minimum in addition to Design Guidelines. Refer to 4.14 “Material palette”.**

**All designated public open space shall be accessible via either the adopted highway of roads and footways where there are no access restrictions.**

## 4.3 PEDESTRIAN CONNECTIVITY

York Central will provide a series of improved pedestrian connections to surrounding communities and the city centre. It will prioritise sustainable means of travel through well-defined and legible streetscapes consisting of dedicated pedestrian footstreets, generous pavements, and shared dedicated footways/cycle ways which connect through the site to promote walking and cycling.

The proposed pedestrian network connects the different communities and streetscapes with public open spaces through a clear hierarchy of interconnected routes. It should be designed to be considerate of different user groups and their varying needs and in all cases should promote walking and contribute to a wider sense of pedestrian primacy on streets.

There will be dedicated footways on local streets, with footpaths through the park, accessible level changes, clearly delineated pedestrian routes and crossings, new or improved pedestrian & cycle connectivity to the south. A segregated pedestrian access will be provided through the Leeman Road Tunnel and there are opportunities for improved connections with St Peter's Quarter. The National Railway Museum proposals will seek to maximise permeability of the site for pedestrian access whilst maintaining security.

In order to promote pedestrian connectivity, the following principles shall be observed:

**Streets and junctions shall be designed to encourage and facilitate safe pedestrian movement and connectivity between spaces.**

**Dedicated footways, with places to sit, street lighting, shade and shelter through tree planting, shall be provided for the primary streets.**

**Routes shall be convenient, direct and follow pedestrian desire lines.**

**Informal crossing points shall be incorporated at strategic points, along primary and secondary streets.**

**Street tree and planting character shall vary within street typologies to contribute to legibility and way finding.**

**Pedestrian connections via Chancery/Wilton Rise will be high quality, well lit and clearly delineated from the cycle route.**



Fig.118 Site plan showing pedestrian movement network



Fig.119 Places to sit along major pedestrian routes



Fig.120 'Pedibus', school transport, Lyon



Fig.121 Pedestrian movement integrated within landscape



Fig.122 Pedestrian street, Pantiles, Tunbridge Wells

## 4.4 CYCLIST CONNECTIVITY

A well structured new cycle network will connect the site to the existing city and promote sustainable means of travel. The cycle network will provide cycle links through and around the Proposed Development areas and into the park. Cycling is promoted site wide with space shared with pedestrians throughout the site.

The proposed cycle network links the key public spaces, residences and work places in the site to the wider city of York. A dedicated cycle route will extend east-west the length of the site, with improved connections at Leeman Road Tunnel which leads to Station Rise, Water End, and Leeman Road Underpass through to Kingsland Terrace. A new cycle hub and cycle parking at York Railway Station will support cycle commuting and visitors to the site and National Railway Museum. A new connection will also be formed via either Wilton Rise or Chancery Rise and will integrate the York Central cycle network into the established cycle routes within the wider city.

**Cycle connections via Chancery/Wilton Rise will be high quality, well lit and clearly delineated from the pedestrian route. Ramps shall be provided at an appropriate gradient for the transition of levels.**



Fig.123 Site plan showing cycle routes network





Fig.124 Cycling infrastructure built into streetscape



Fig.125 Dedicated cycleway, France



Fig.126 Cycle safe street, Vauban, Germany



Fig.127 Public bike repair stand, London



Fig.128 Cycle friendly road infrastructure



Fig.129 Shared pedestrian and cycle space

#### 4.4.1 Dedicated cycleways

A dedicated cycle way shall be provided along primary streets (Western Access Road, Park Street, Leeman Road East) and Hudson Boulevard. Links into this route shall be provided across Central Park via Kingsland Terrace, Leeman Road and Wilton Rise.

Dedicated cycle ways shall be delineated through a change in material from the adjacent footway – through colour, unit size and texture.

Layout and design should provide legible separation between pedestrians and cyclists in order to design out conflict.



Fig.130 Dedicated cycle way (left) and correct use of materials (right)



#### 4.4.2 Cycling on the carriageway

Secondary Streets and tertiary streets shall be lower in speed and predominantly residential in nature therefore cycle lanes shall not be marked on the carriageway.



Fig.131 Cyclists on carriageway.



#### 4.4.3 Shared cycle/pedestrian routes

Cyclists shall share space with pedestrians on Hudson Boulevard and Cinder Yards and hard landscaped civic space.



Fig.132 Bikes and pedestrians share a space



#### 4.4.4 Cycle safe streets

Tertiary and access streets shall be designed in a way that facilitates safe cycling within the roadway.



Fig.133 On road cycling



#### 4.4.5 Cycle junctions

Cycle junctions within the primary road way shall be designed in a way that facilitates safe crossing and clear delineation of priority for cyclists and for pedestrians.

Cycle junctions with pedestrian routes shall be delineated through a change in material - colour, unit size, texture.

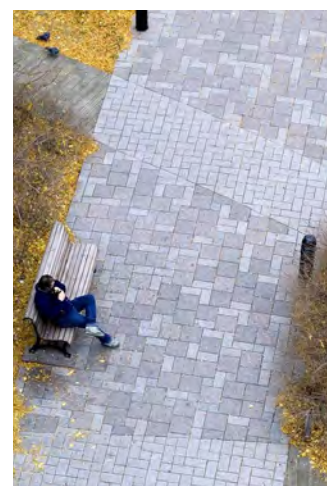

Fig.134 Junctions that allow safe crossing



#### 4.4.6 Cycle parking

On street cycle parking shall be provided on all primary streets, Hudson Boulevard and hard civic public open spaces.



Fig.135 Cycle parking on pavement or on dedicated cycleway



## 4.5 PRIMARY STREETS

The east-west route through the site forms the primary vehicular access through and into York Central. It provides the network for local buses through the site in alongside access to adjoining roads and properties. The characteristics of the street vary along its length as it passes through different parts of the site.

The primary street begins/ends at the western access to the site at Water End and passes through the site to connect with the Leeman Road tunnel.

The character of the street changes as it passes through the different areas of the site. To address this in the Design Guide we have attributed different names to the street as it flows through the Masterplan. The 'Western Access Road' passes over the new bridge to the rail network and meets the junction with Leeman Road West where it becomes 'Park Street' - passing between the residential district of York Yard South and Central Park.

Moving into the Station Quarter and the commercial areas of the site, it becomes 'Cinder Street' - connecting Hudson and Wilton Place, before passing into New Square. In the square it becomes Leeman Road East, moving through the Leeman Road Tunnel and forming the eastern site access with Station Rise.

It is envisaged that the primary network will be adopted by CYC. As such **it must be designed to meet CYC adoption standards as a minimum.**

**The design of Primary Streets must encourage low vehicular speed appropriate to the local environment and promote pedestrian and cyclist connectivity.**

**Footways shall be no less than 3m (including street tree planting zone) this may be reduced to 2.5m where there is the provision of a bus stop or on street parking and 2m along the park edge.**

**Junctions and areas where the primary streets form part of public open spaces will be of an enhanced material palette and shall be fully integrated with the design proposals for the public open space. See 4.14 "Material palette".**

**Street trees shall be planted along the length of the primary street in combination with a hedgerow under-storey. See 4.13 "Street tree framework".**

**Places to sit and appropriate street furniture must be provided at regular intervals.**

Electric vehicle charging points may be integrated as appropriate.

An appropriate number of spaces for car sharing schemes should be provided.



Fig.136 Site plan showing Primary streets



Fig.138 Market Street, San Francisco



Fig.139 'Parklet' and seating integrated street design



Fig.137 Hope Street, Liverpool



Fig.140 Park edge, Highbury Fields London



Fig.141 Dedicated cycleway, London

#### 4.5.1 Park Street

Park Street will be predominantly residential in nature and supportive of the park side communities that it bounds. It should feel as if it is part of the park and facilitate easy, safe, direct, pedestrian movement across from the residential communities into the central green space. It must also support the homes in York Yard South by providing public transport interchanges, residential and visitor parking. The following principles shall be applied when designing interfaces with Park Street:

**A dedicated cycleway shall be provided along the length of Park Street with links into routes within Central Park. Designated cycle paths and footways shall be separated by a 1.5m wide planted verge.**

**Breaks within the planted verge shall facilitate the inclusion of street furniture and allow for pedestrian crossing points and places to sit.**

**Street trees shall be provided along the length of the park edge in combination with a hedgerow under-storey. Street trees should be provided along the southern edge of the street except where there is a planted median or bus stop.**

**Measures to reduce forward driver visibility shall be incorporated within the design of the street to reduce vehicle speeds and foster a safer environment for pedestrians and cycles.**

**Planted medians shall be provided at intervals along the length of Park Street to reduce forward visibility and therefore vehicle speed. These shall also serve to integrate the street into the park landscape and to provide refuges for pedestrians to cross the carriageway.**

**Some limited and controlled on street parking shall be permitted. Where this occurs, to encourage low vehicle speeds, the carriageway shall narrow to 5m. No more than four parking bays shall be placed together before they are broken by a soft landscape zone or street tree.**

**Bus stops shall be included. A 400m walking distance for residents shall be a primary factor in their distribution.**

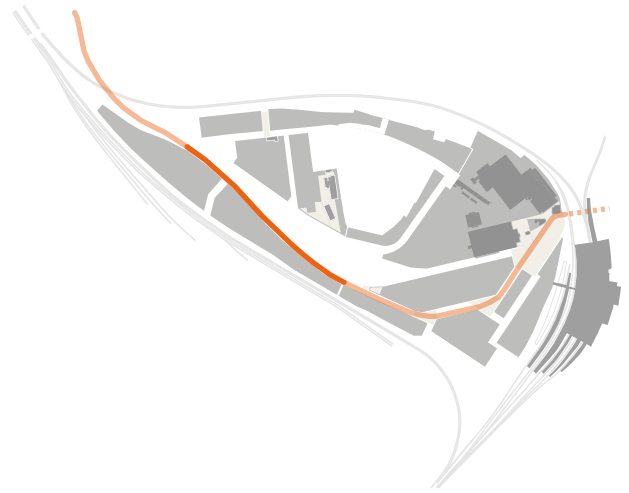

Fig.142 example of a central planted median



Fig.143 Highbury Crescent, Highbury Fields London

### 4.5.2 Park Street: Typical

This section shows the typical arrangement of the carriageway with the dedicated cycleway and footway running alongside the park. A line of trees separates the cycle and footways, and screens the pavement on York Yard South.

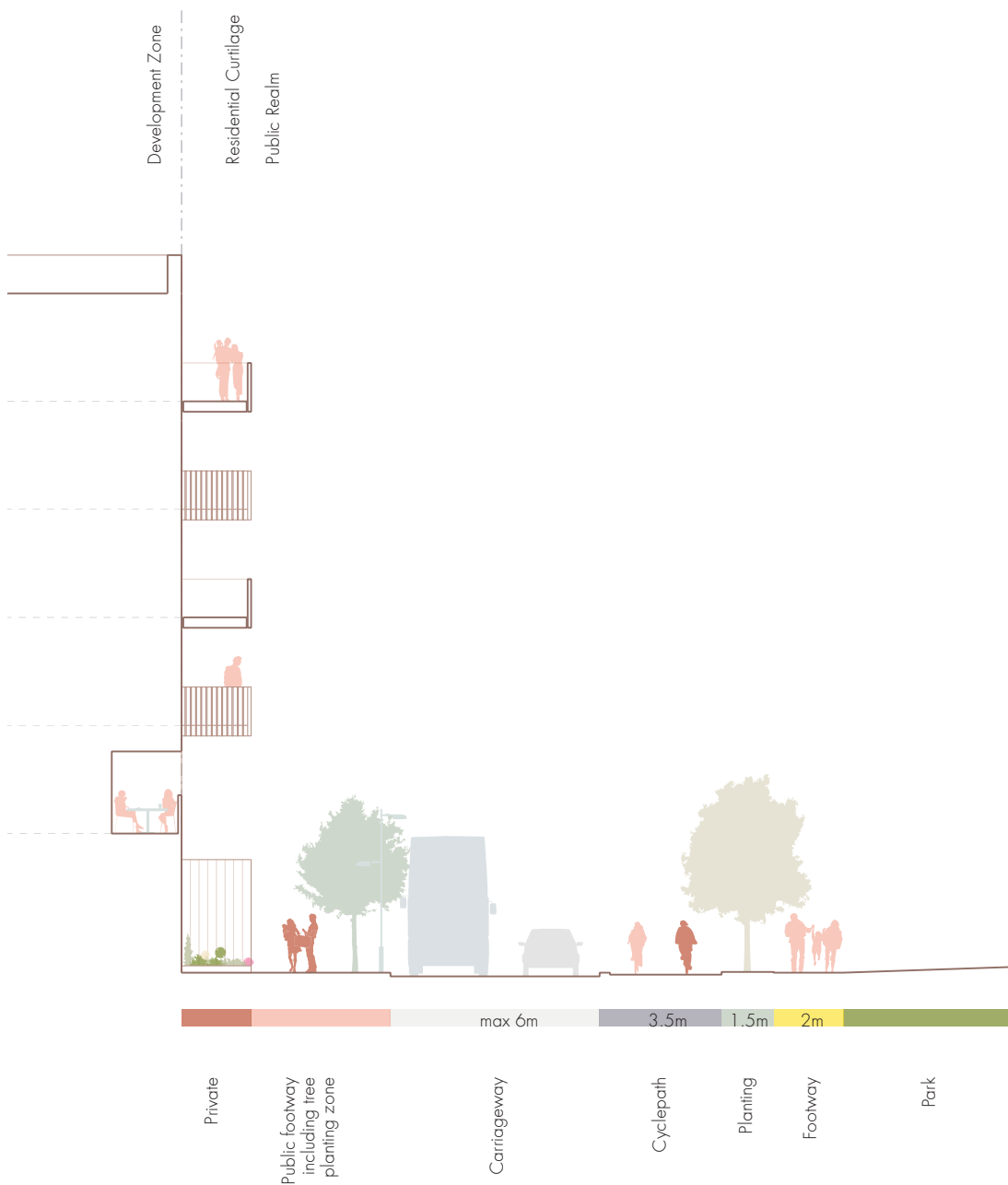
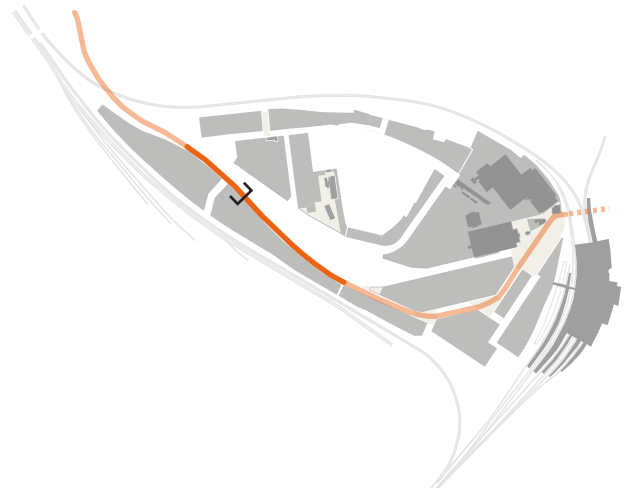
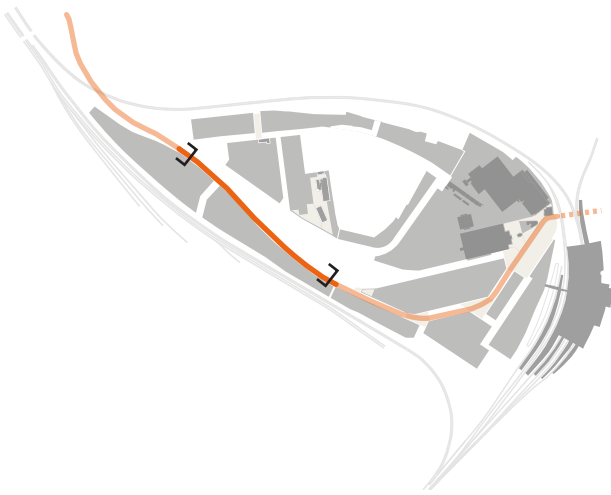

Fig.144 Illustrative typical section showing building and park facing a primary street



**4.5.3 Park Street: central median**

In addition to the measures set out on the preceding pages:

**Where a planted median is provided street trees are not required on the southern edge of the carriageway. Street trees must still be provided along the Park edge.**



Fig.145 Illustrative section showing carriageway split by a central planted median



#### 4.5.4 Park Street: on street parking

Where on street parking is provided the maximum carriageway width shall be 5m

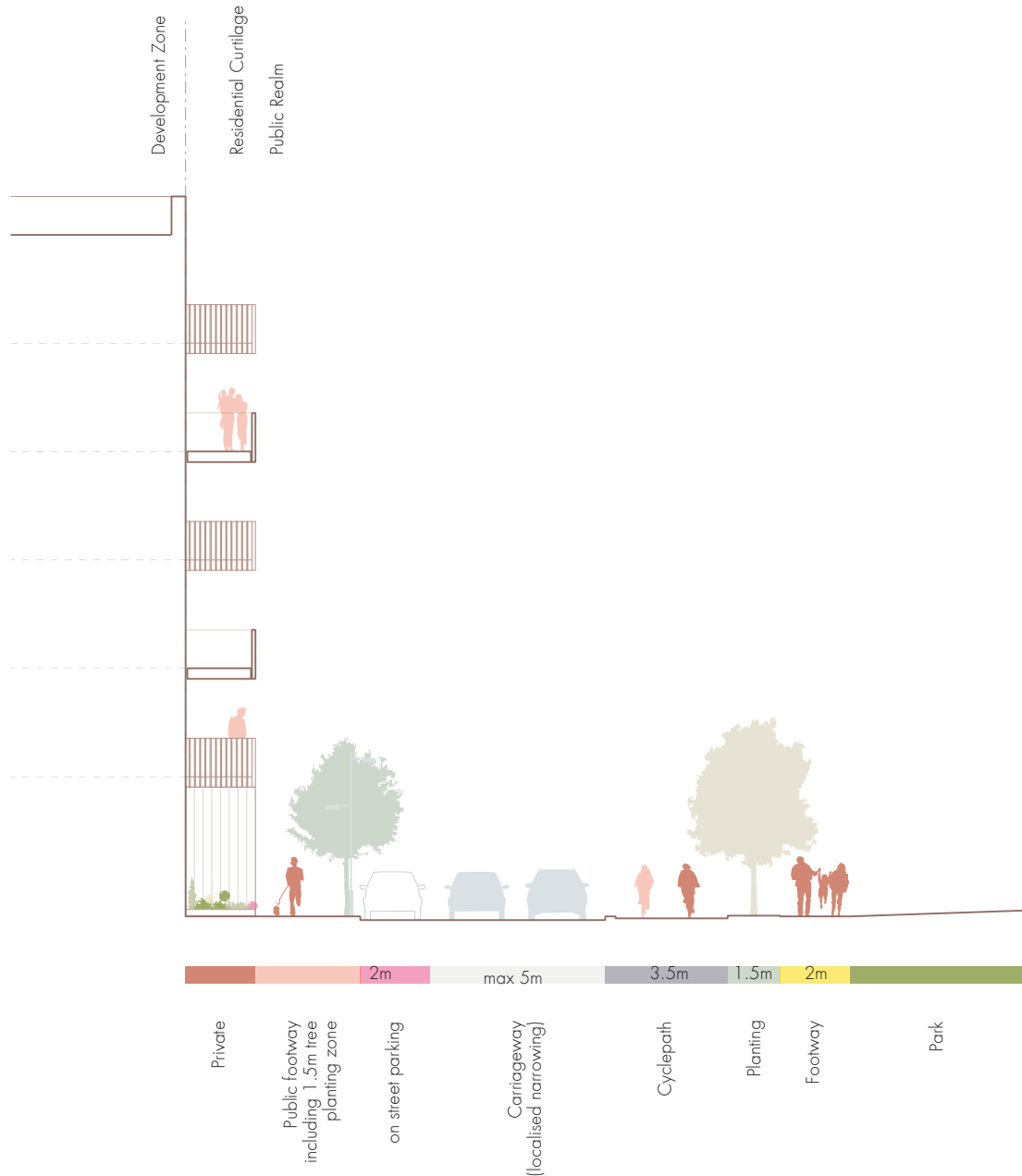
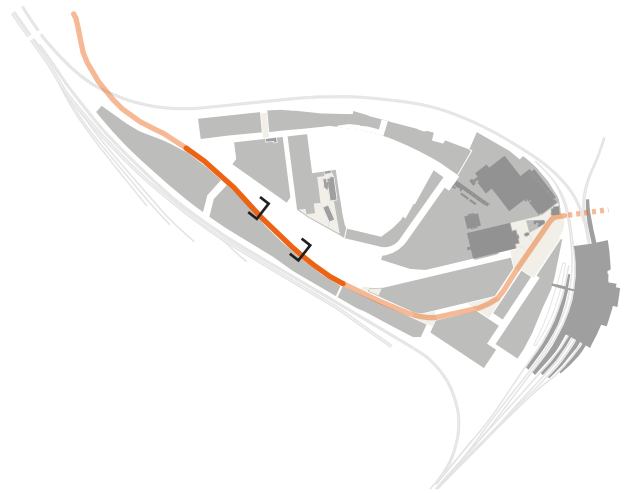

Fig.146 Illustrative section showing the possibility of having on street parking along primary street

**4.5.5 Park Street: commercial use and bus stop**  
 To encourage low vehicle speeds bus stops shall be incorporated within the width of the carriageway.

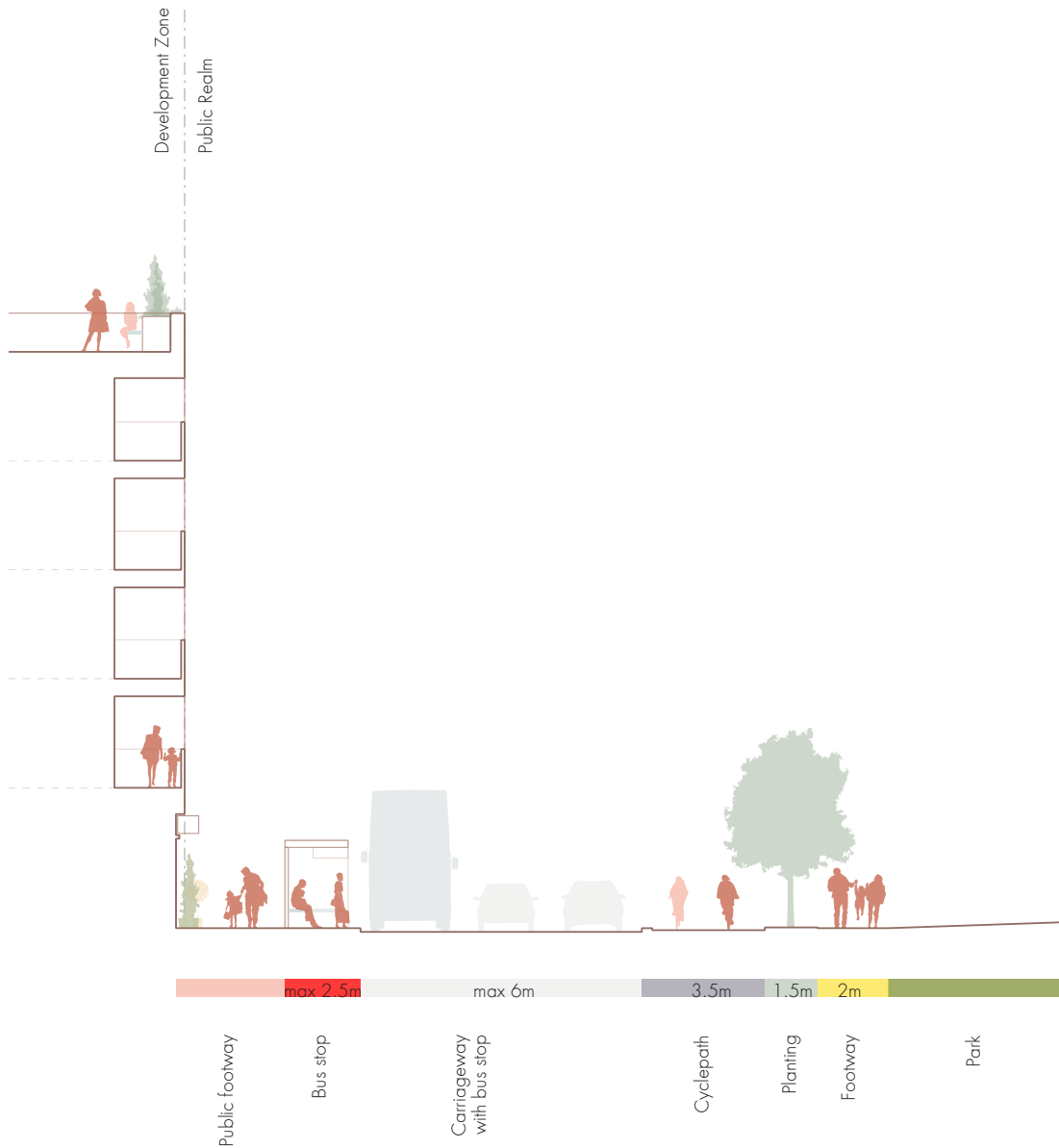
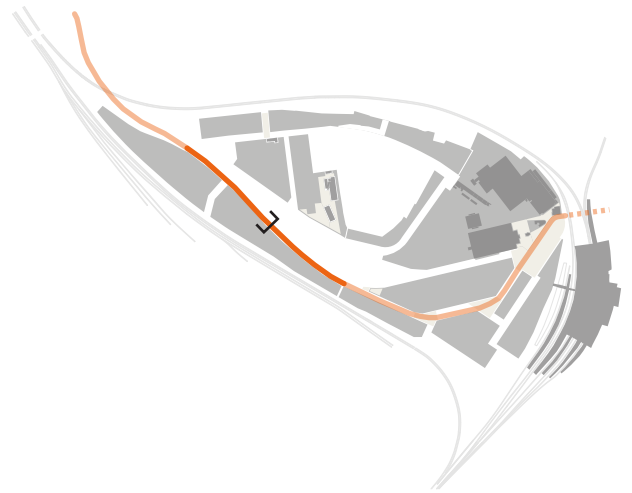

Fig.147 Illustrative section showing a commercial use at the ground floor and the bus stop

**4.5.6 Park Street: central median with on street parking**

Where on street parking is provided the maximum carriageway width shall be 5m.

Where a planted median is provided street trees are not required on the southern edge of the carriageway. Street trees must still be provided along the Park edge.

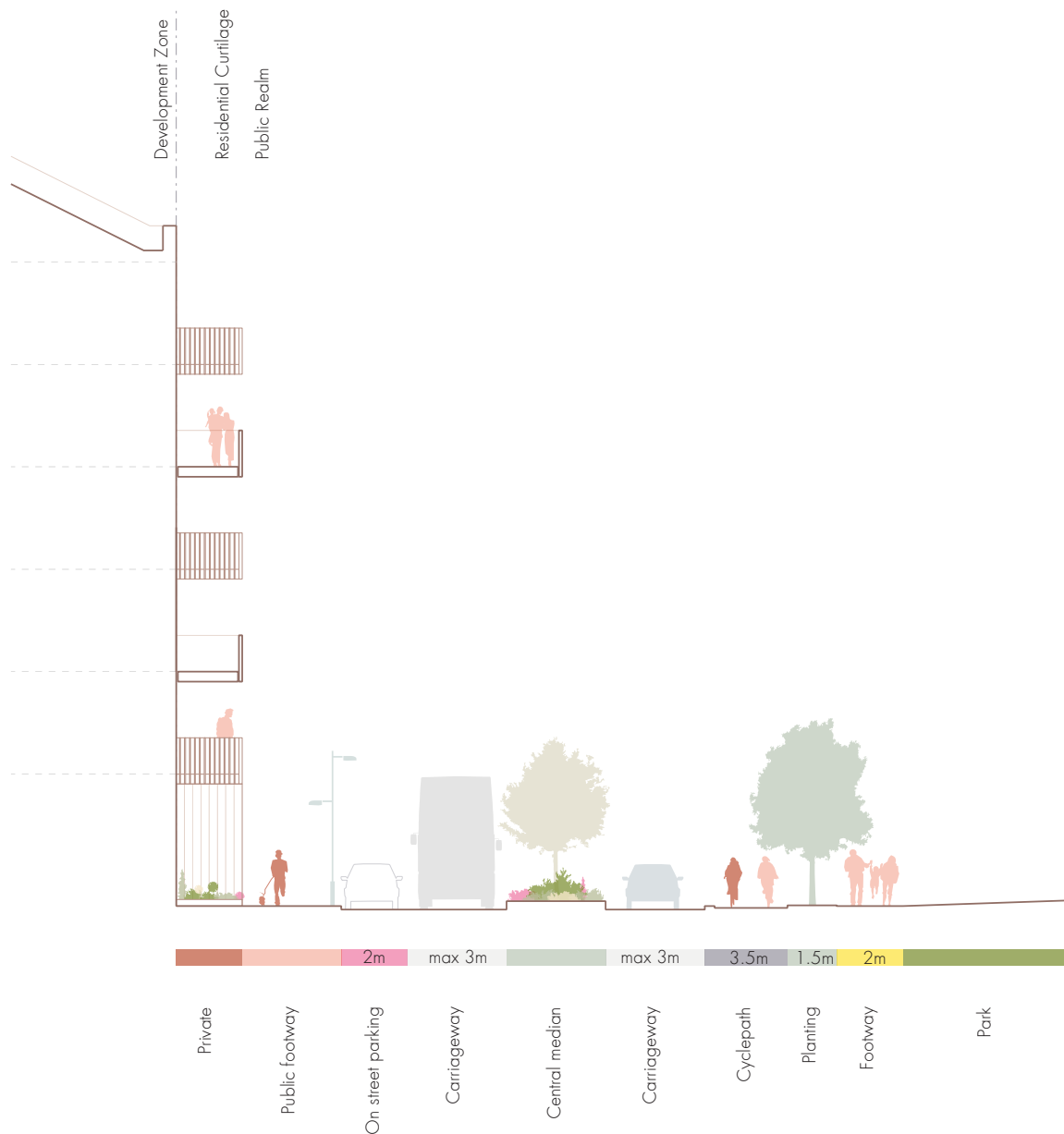
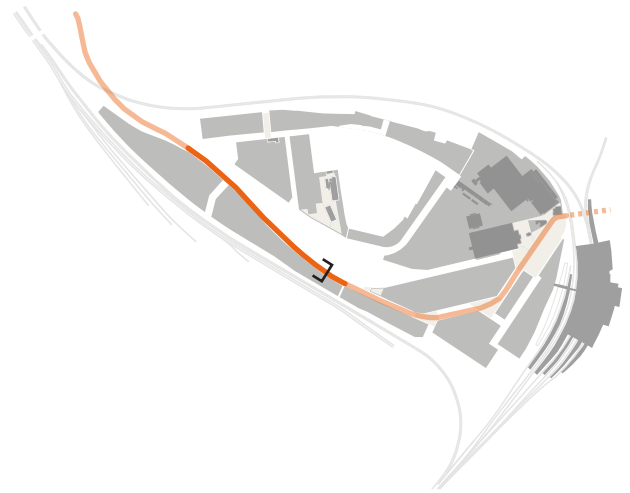
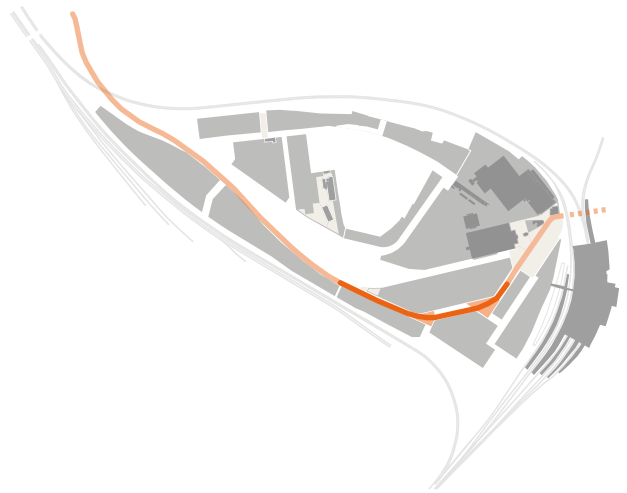

Fig.148 Illustrative section showing the option allowing both the on street parking and the central planted median



#### 4.5.7 Cinder Street

Fronted by shops, cafés, offices and residential entrances, Cinder Street will act as a destination within York Central. It forms the primary pedestrian and vehicular link between the New Square and the rest of York Central. The street should be generous in nature and provide places to sit for shoppers and workers on their breaks, space for ‘sometime uses’ such as markets.

The street will be defined by both the buildings which enclose it and the landscaping and areas of public realm that it connects from George Square through to Hudson Place, Wilton Place and New Square.

The following principles shall be applied when designing interfaces with Cinder Street:

**A central planted median shall be placed between Hudson and Wilton Place. This shall be broken only by pedestrian crossing points.**

**Pedestrian footways shall be a minimum of 4m wide.**



Fig.149 Street market, Paris



Fig.150 Marylebone Highstreet, London

### 4.5.8 Cinder Street: George Square

George Square acts as the western gateway to the Station Quarter and is intended as a predominantly hardscaped space looking out over the park. There is potential to include a playground element/boules/fitness component for use by local community residents and worker.

**A dedicated cycleway shall be provided along the park edge**

**Cycling shall be permitted within the public realm.**

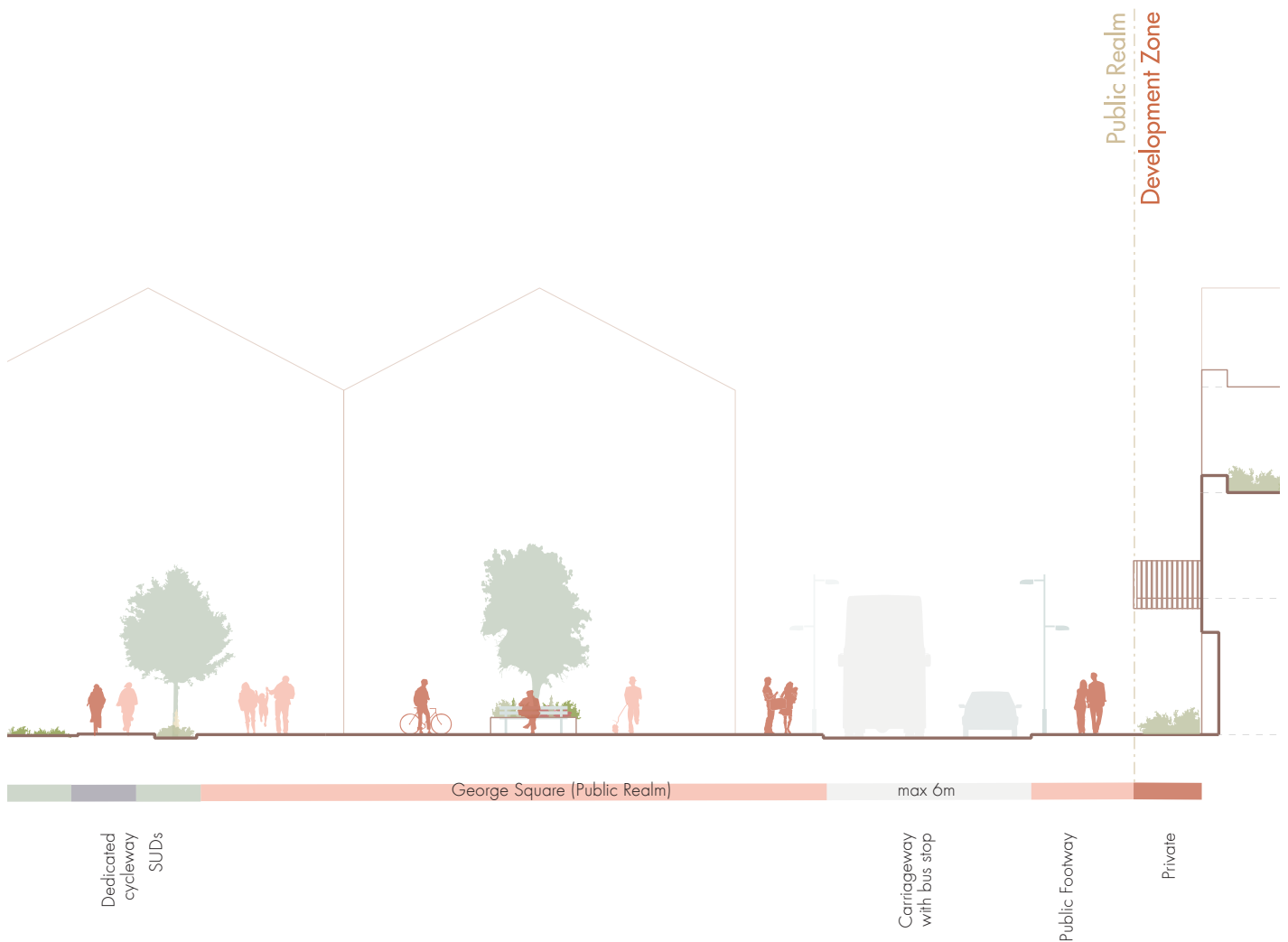
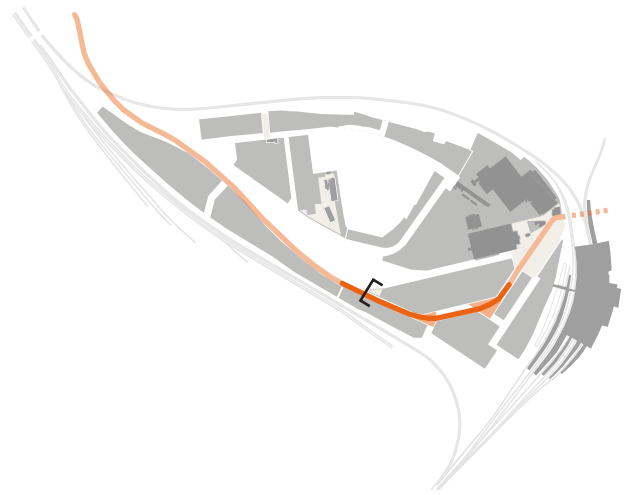

Fig.151 Illustrative section showing possible arrangement on George Square

#### 4.5.9 Cinder Street: Hudson/Wilton Place

Hudson/Wilton Place shall be designed as pedestrian priority spaces.

Cycling shall be permitted within the public realm.

Places to sit shall be included in the landscape/hardscape design.

Biophilia shall be a consideration of the landscape/hardscape proposals.



Fig.152 Kings Square York

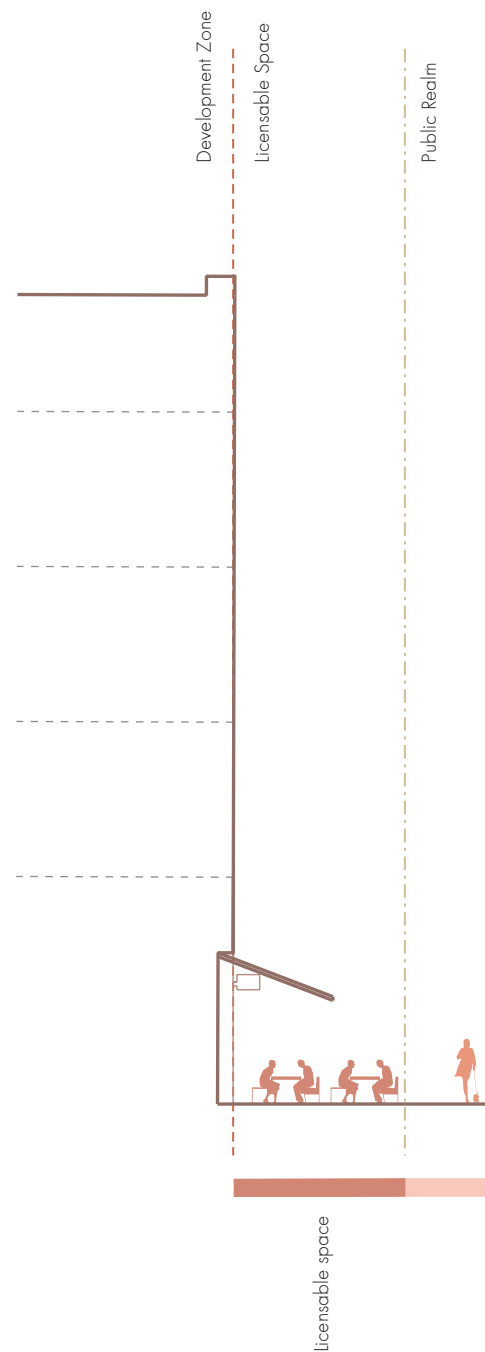

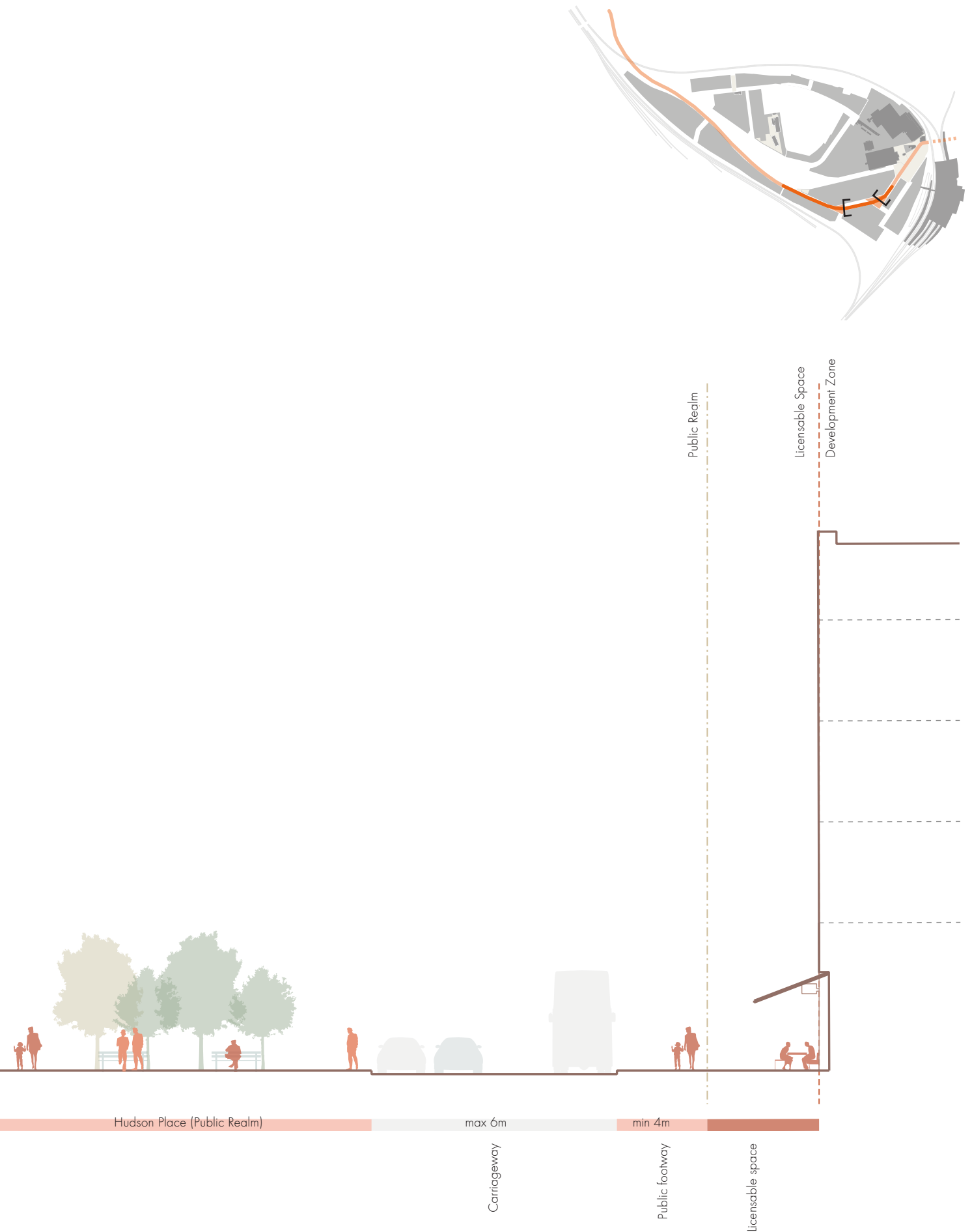

Fig.153 Illustrative section showing possible arrangement for Hudson Place

#### 4.5.10 Cinder Street: Planted median

This typical section through Cinder Street shows the central planted median, a wide pavement to the north side of the street creating a generous public space in the centre of Station Quarter.

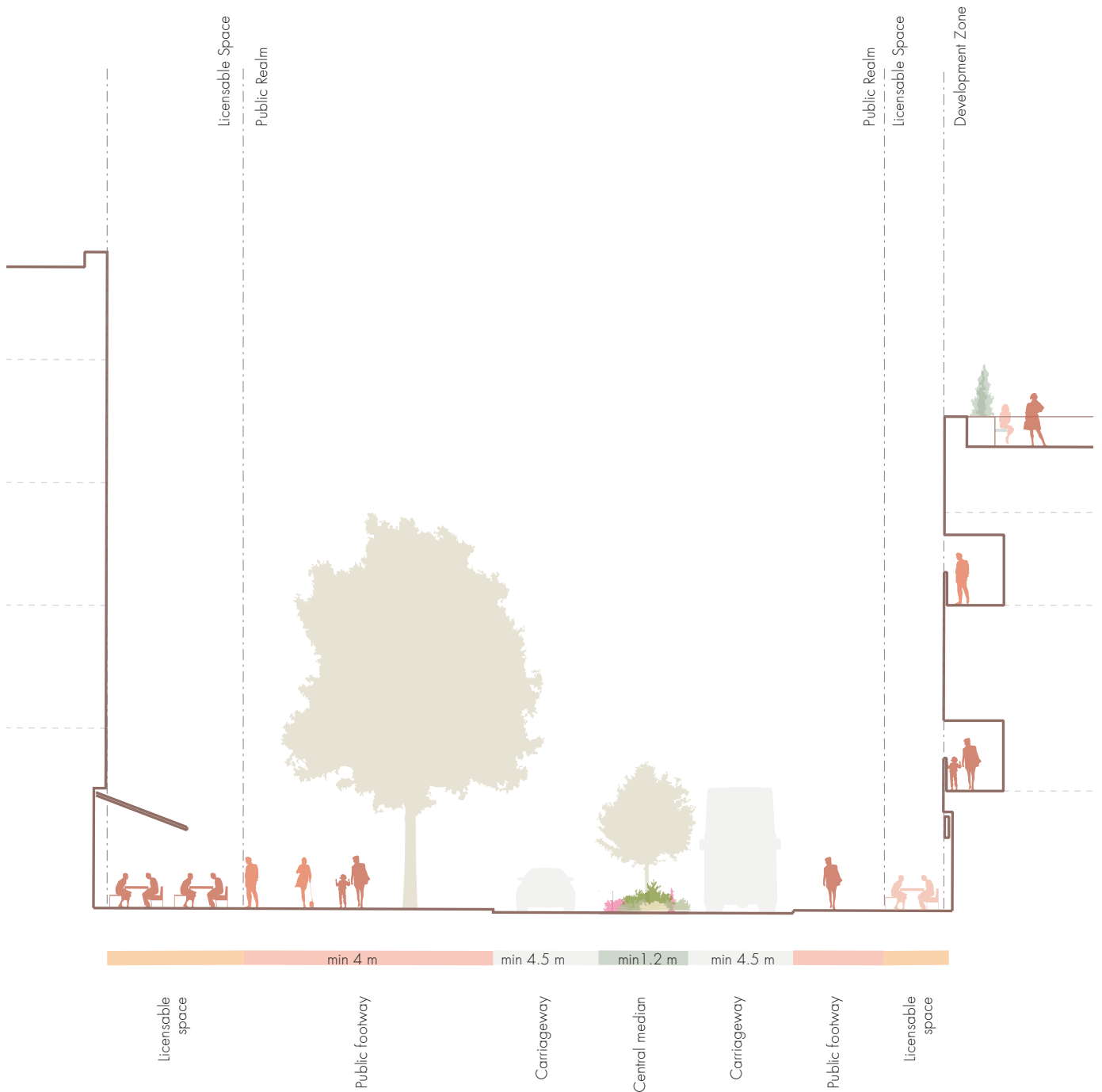
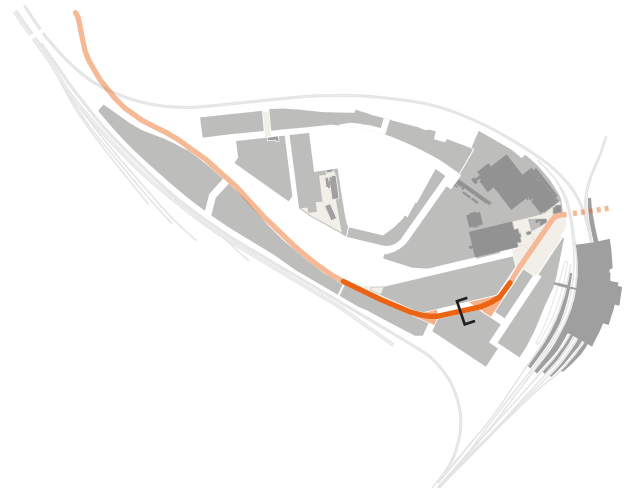

Fig.154 Illustrative section showing Cinder Street with planted median in the carriageway



#### 4.5.11 Cinder Street: Bus stop before New Square

Where a bus stop is provided within Cinder Street it may be necessary for the public footway to sit within the Development Zone. This may be provided as a building set back or via an undercroft arrangement.

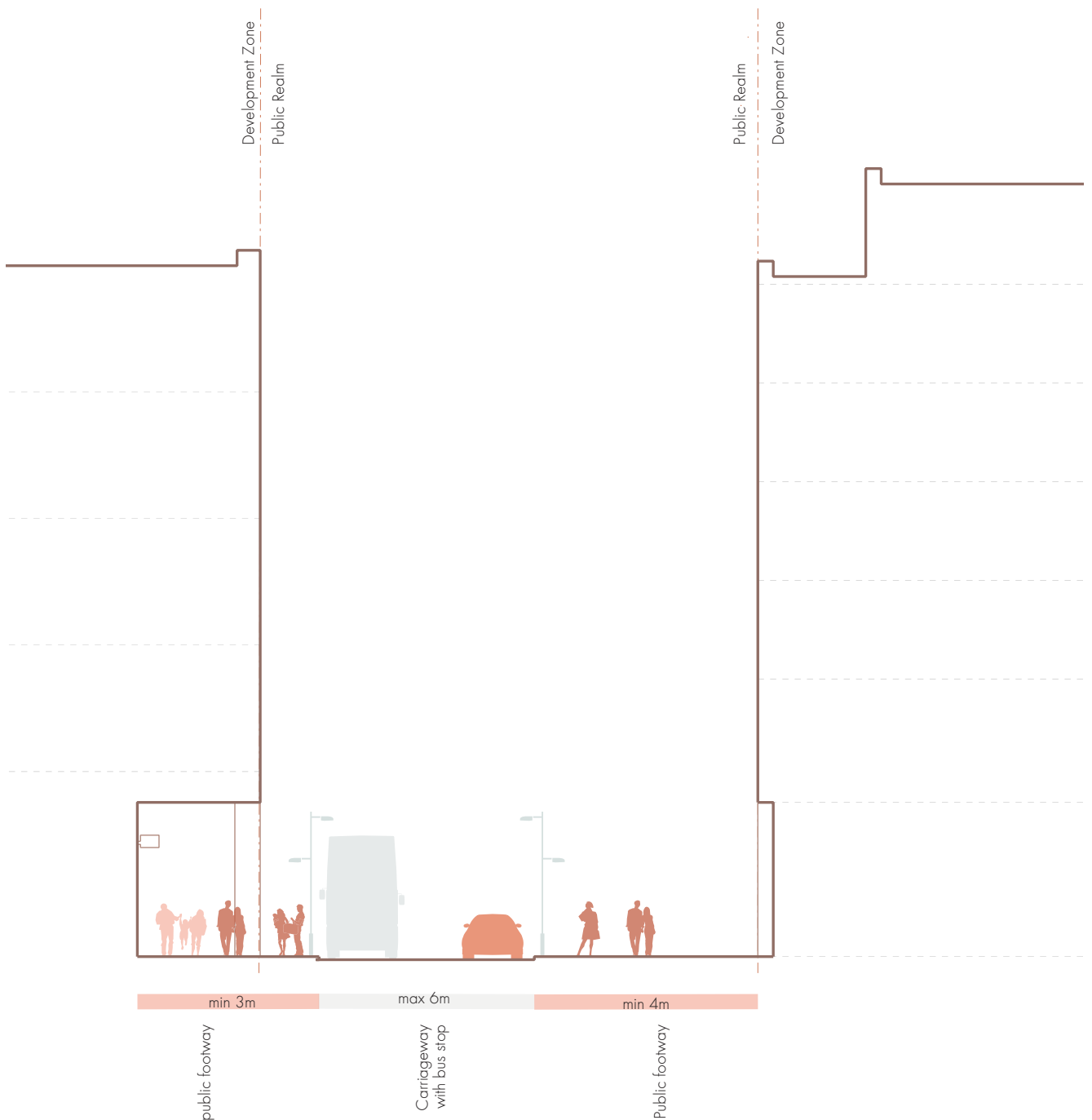
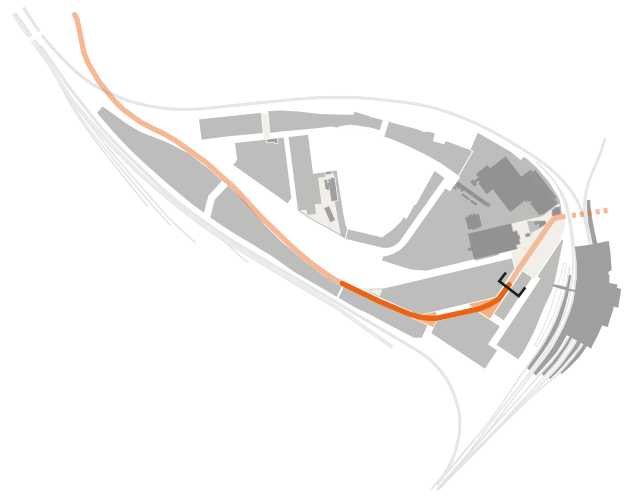
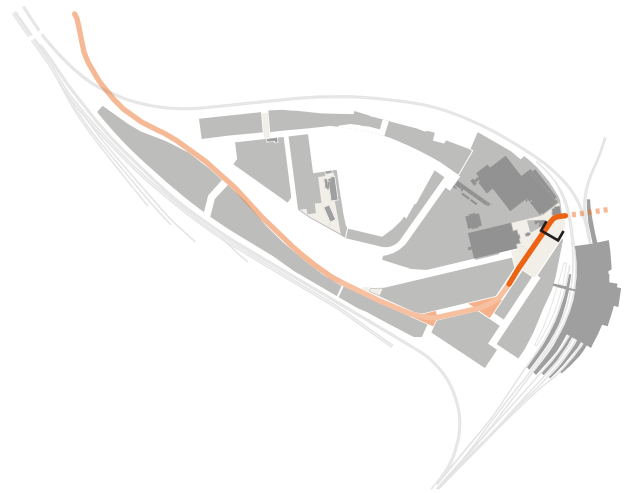

Fig.155 Illustrative section showing development requirement adjacent to bus stops



#### 4.5.12 Leeman Road East

Leeman Road East passes through New Square and divides the space into two new areas of public realm, Museum Gateway which is centred on the National Railway Museum and Station Gateway, which comprises the Coal Drops and Station Entrance.

New Square will include one signalised pedestrian crossing on the key desire line between the National Railway Museum and Station.

An additional crossing between the Leeman Road Tunnel and the National Railway Museum will be considered. See section “4.11 Road Crossings”.

There is no requirement for designated ‘footways’ in this area as the entire space outside the line of the carriageway is intended to be pedestrianised public realm.

Beginning in line with the coal drops, a dedicated cycleway shall be provided along the north edge of the carriageway and this will extend through the Leeman Road Tunnel to connect to the existing cycle network at Lendal Arch and Scarborough Bridge cycle route.

The public realm edge immediately to north of the Coal Drops shall not be used as a footway. Measures to discourage pedestrian use of this area should be adopted, for example through tree planting, landscaping, and/or use of deterrent surfacing.

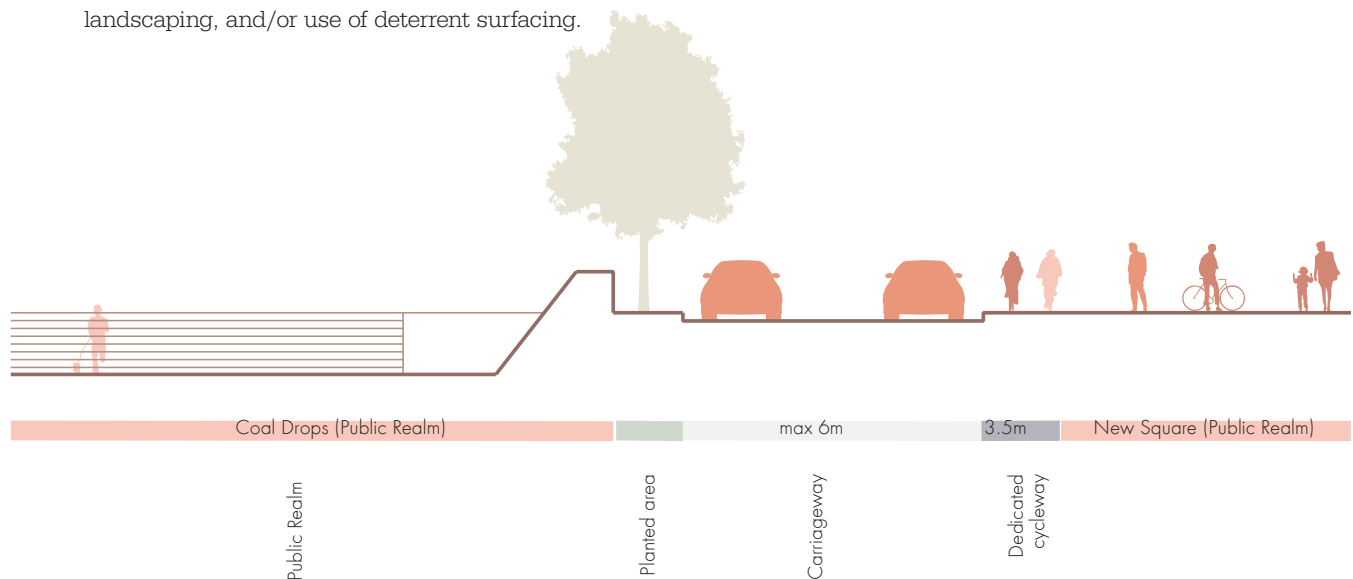

Fig.156 Illustrative section showing carriageway adjacent to Coal Drops



Fig.157 Railway sleepers used as benches in public square



Fig.160 Hope Street, Liverpool



Fig.158 Plaza de la luna, Madrid



Fig.161 David H Koch Plaza, New York



Fig.159 Veenendaal, Netherlands



Fig.162 Stranden, Aker Brygge

## 4.6 SECONDARY STREETS

The secondary streets of York Central provide access to properties and through routes within the residential area, permitted residential and commercial parking. They are intended for predominantly private vehicular traffic, taxis and cycles and include footways which form a key part of the pedestrian movement network.

Leeman Road West and Foundry Way provide access through the Foundry Village, Central Park and rear of the National Railway Museum. These streets comprise a carriageway with marked cycleway, dedicated pedestrian footways on either side, landscaping/tree planting. The qualities of the streets vary according to their immediate context and the building typologies which front them.

**The design of secondary streets must encourage low vehicular speed appropriate to the local environment and promote pedestrian and cyclist connectivity.**

**The carriageway shall be a maximum width of 5.5m.**

**Some limited and controlled on street parking shall be permitted appropriate to the needs of the adjacent communities. Where this occurs, to encourage low vehicle speeds, the carriageway shall narrow to 5m. No more than four parking**

**bays shall be placed together before they are broken by a soft landscape zone or street tree.**

**Junctions and areas where the secondary street forms part of public open spaces will be of an enhanced material palette and shall be fully integrated with the design proposals for the public open space. See 4.14 "Material palette".**

**Street trees shall be provided at regular intervals on one side or both sides of the road.**

**Cycle parking shall be provided within the public realm.**

**Places to sit and appropriate street furniture must be provided at regular intervals.**

**A dedicated pedestrian footway shall be provided on both sides of the carriageway with a minimum width of 2m.**

Electric vehicle charging points may be integrated as appropriate.

An appropriate number of spaces for car sharing schemes should be provided.

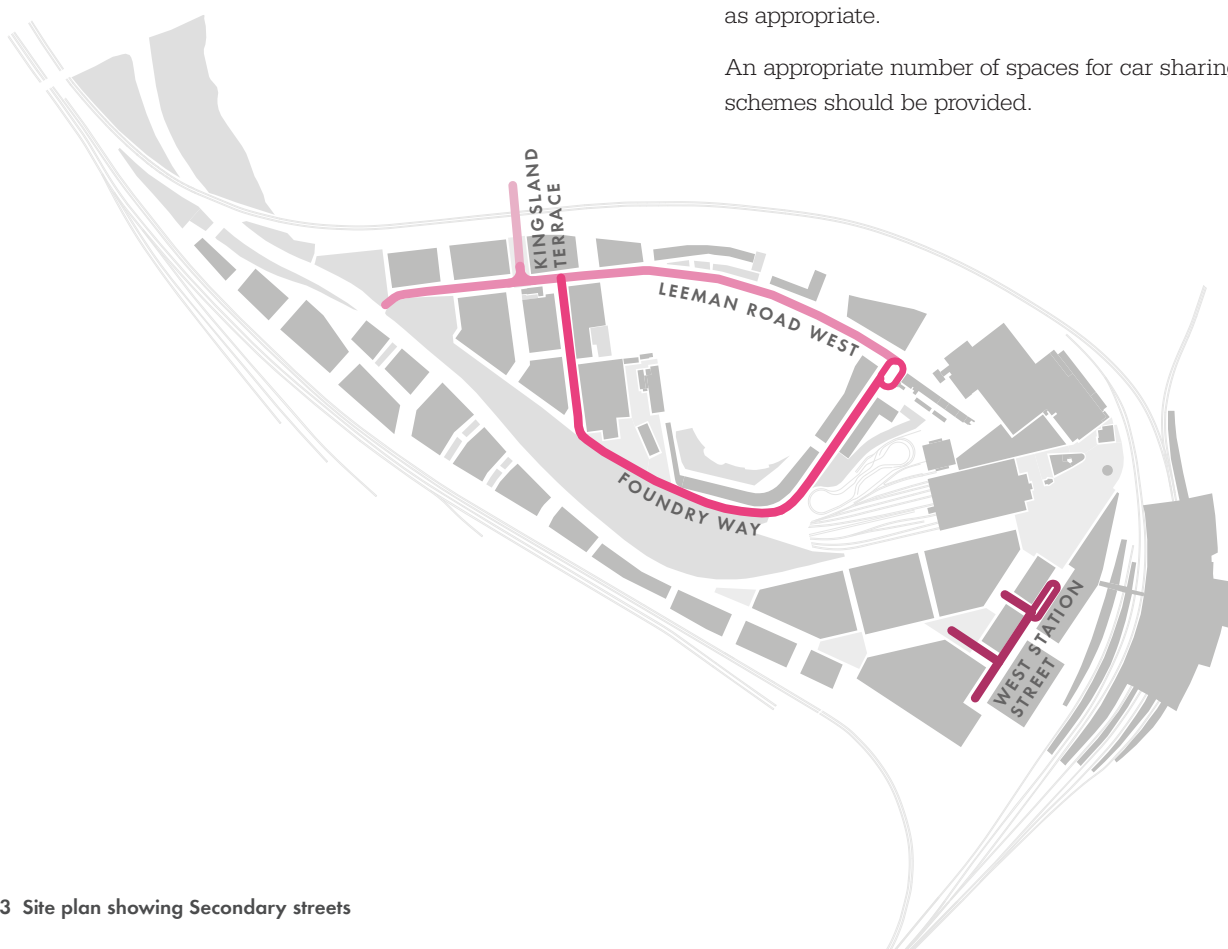

Fig.163 Site plan showing Secondary streets



Fig.164 Henry Street, New York



Fig.166 Derwenthorpe, York



Fig.165 Cambridge, England



Fig.167 Charenton-le-Pont Town Centre, France

#### 4.6.1 Leeman Road West

Leeman Road West is an existing roadway. Kerbs, lighting and surfacing may be adjusted to enhance the street and to enhance the street and reflect reduced traffic flows. The existing Leeman Road has been terminated where it passes through the National Railway Museum. The street connects to the northern most site access via an underpass to Kingsland Terrace and forms a new public open space - the Foundry Square. It also forms a junction with Park Street, provides access for deliveries and maintenance to the National Railway Museum, and provides vehicular access to the existing Siemens Rail Yard site.

**On street parking shall be permitted with the exception of the area around the 'Foundry Square'**

**Provision for delivery and service access for the Railway Museum must be maintained.**

**Access to Siemens Rail Yard shall be maintained.**

**The street design shall be fully integrated with the design of the Foundry Square. If the infrastructure of the street comes in advance of a Reserved Matters Application for the square the carriageway shall be designed to meet with adopted space principles as a minimum see "4.2 Street Adoption"**

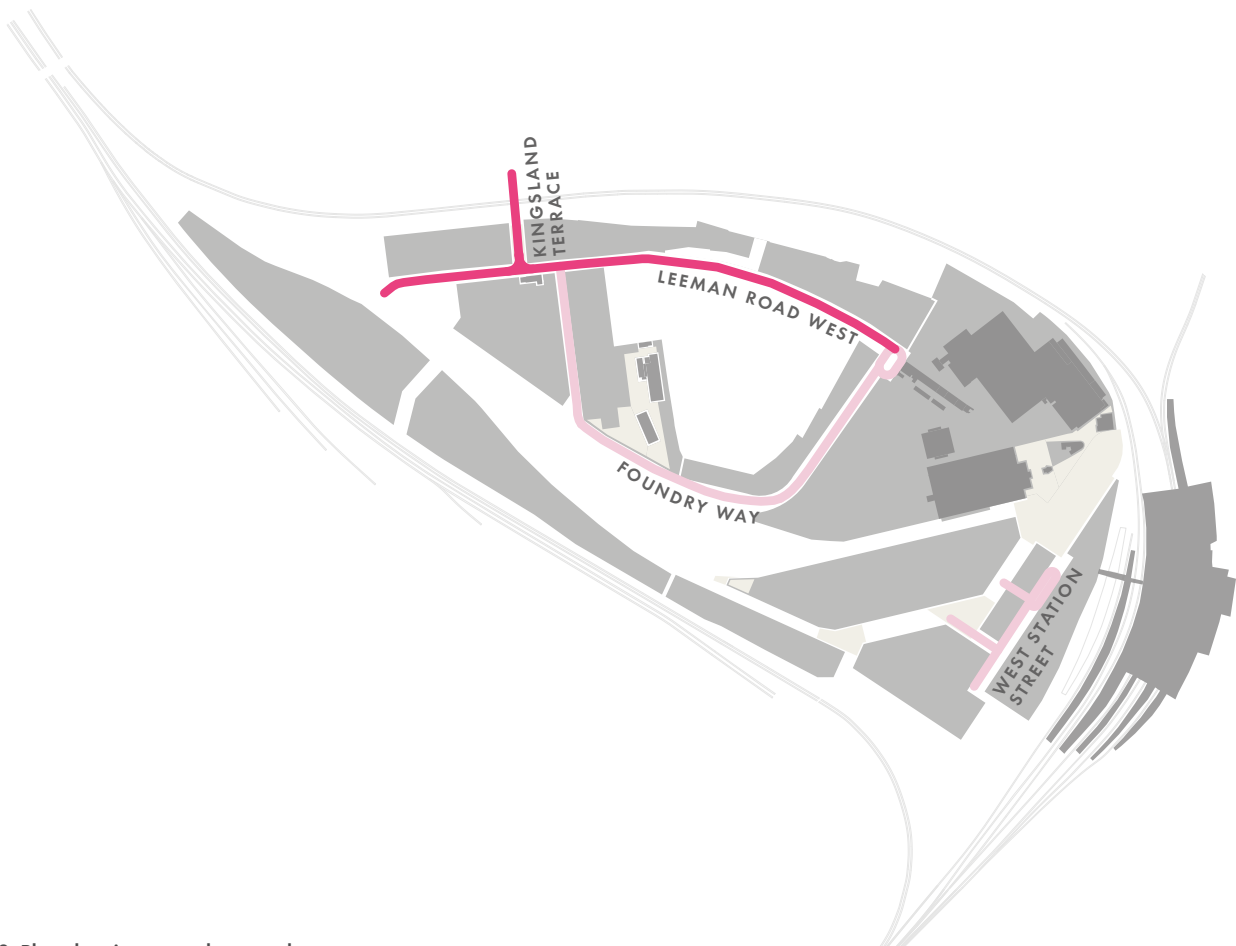

Fig.168 Plan showing secondary roads

### 4.6.2 Leeman Road West: Foundry Square

A pedestrian footway of minimum width of 2m shall be provided on one side of the street. The opposite footway shall be a minimum width of 1.2m and maximum width of 2m.

A landscape buffer zone with graded levels shall be incorporated where there is a height differential of greater than 0.5m between the residential/retail entrance levels and the carriageway.

**When upgrading Leeman Road West in the vicinity of the existing Leeman Road underpass beneath the railway, opportunities for reducing traffic flow shall be explored in conjunction with the Highway Authority.**

**On street parking shall not be permitted in Foundry Square.**

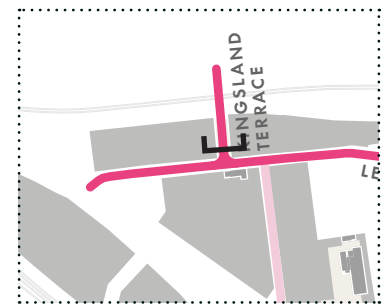
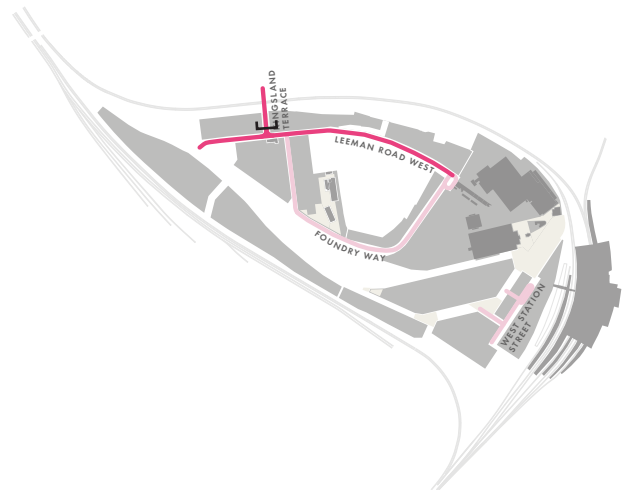

Zoom in

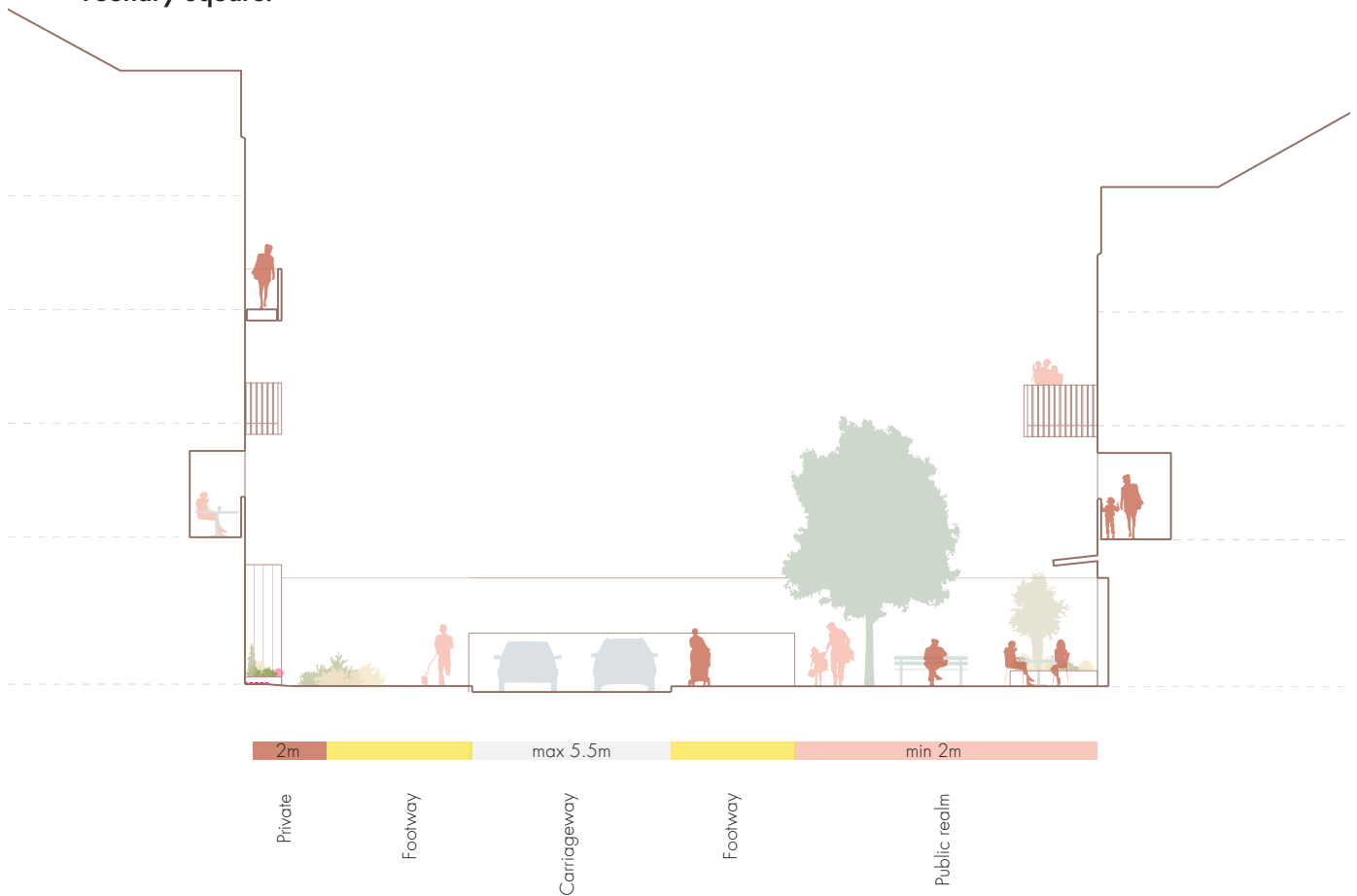
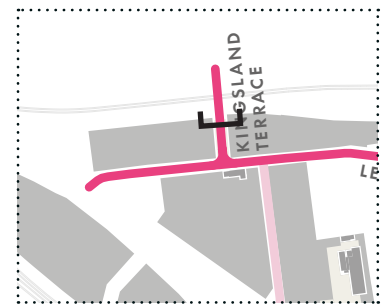
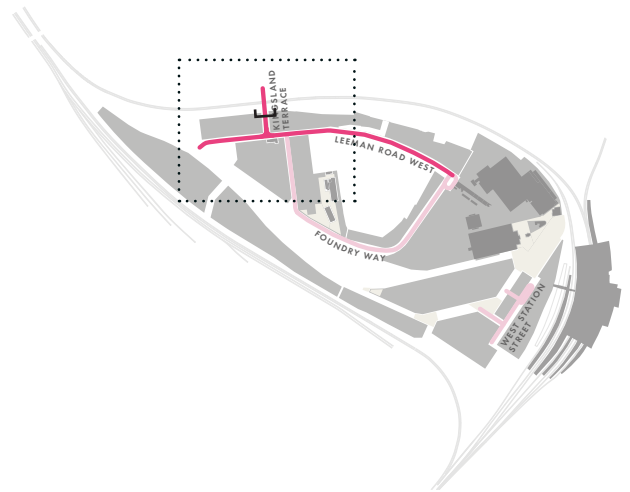

Fig.169 Illustrative section showing Leeman road underpass

### 4.6.3 Foundry Square

This section, cut further towards the bridge, shows the road dropping relative to the ground level of buildings either side. The footway will follow the road both sides and the gently sloping ground up to the buildings will be landscaped and planted.



Zoom in

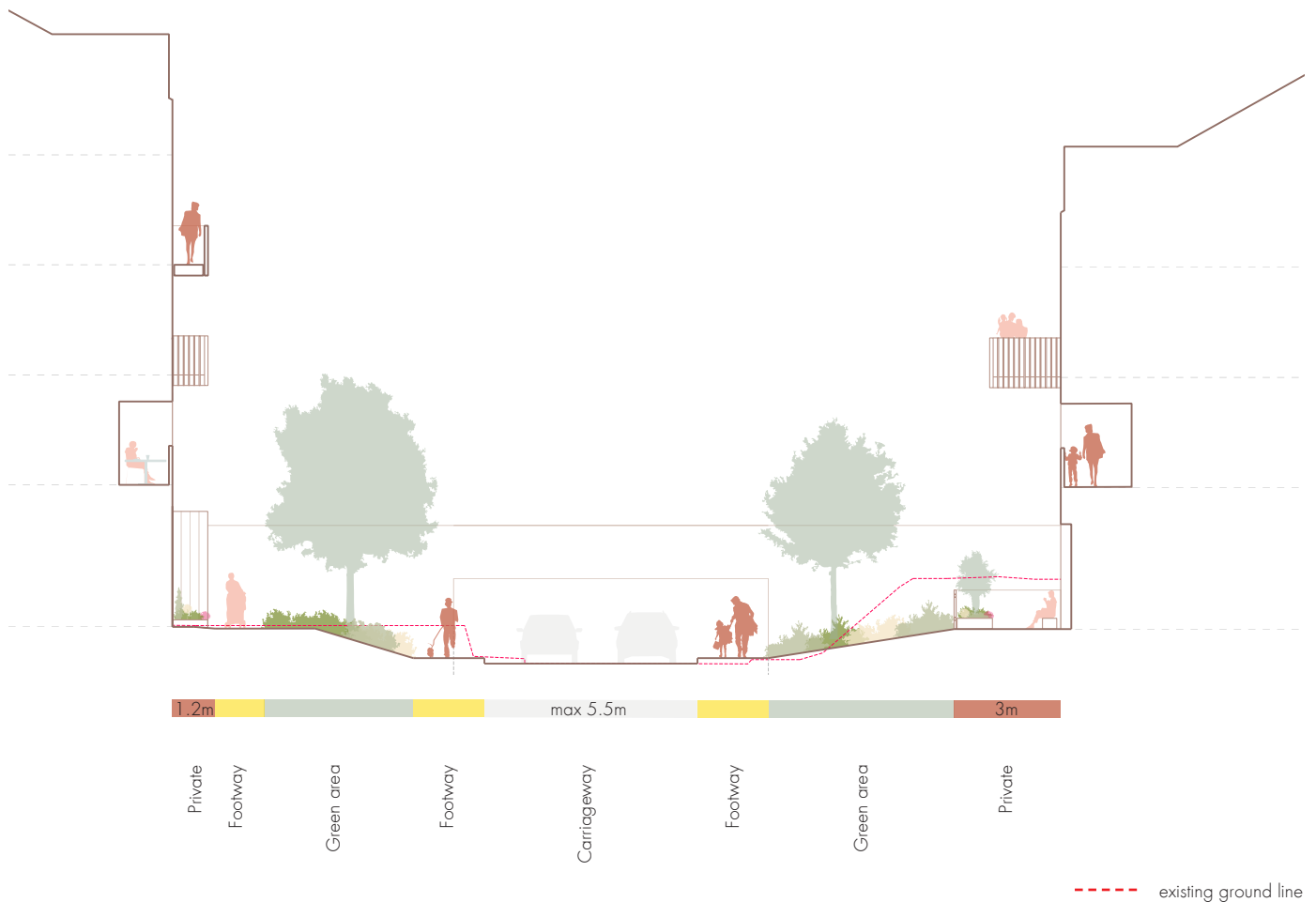

Fig.170 Illustrative section showing Leeman Road underpass



4.6.4 Leeman Road West: Foundry Square section through the existing building

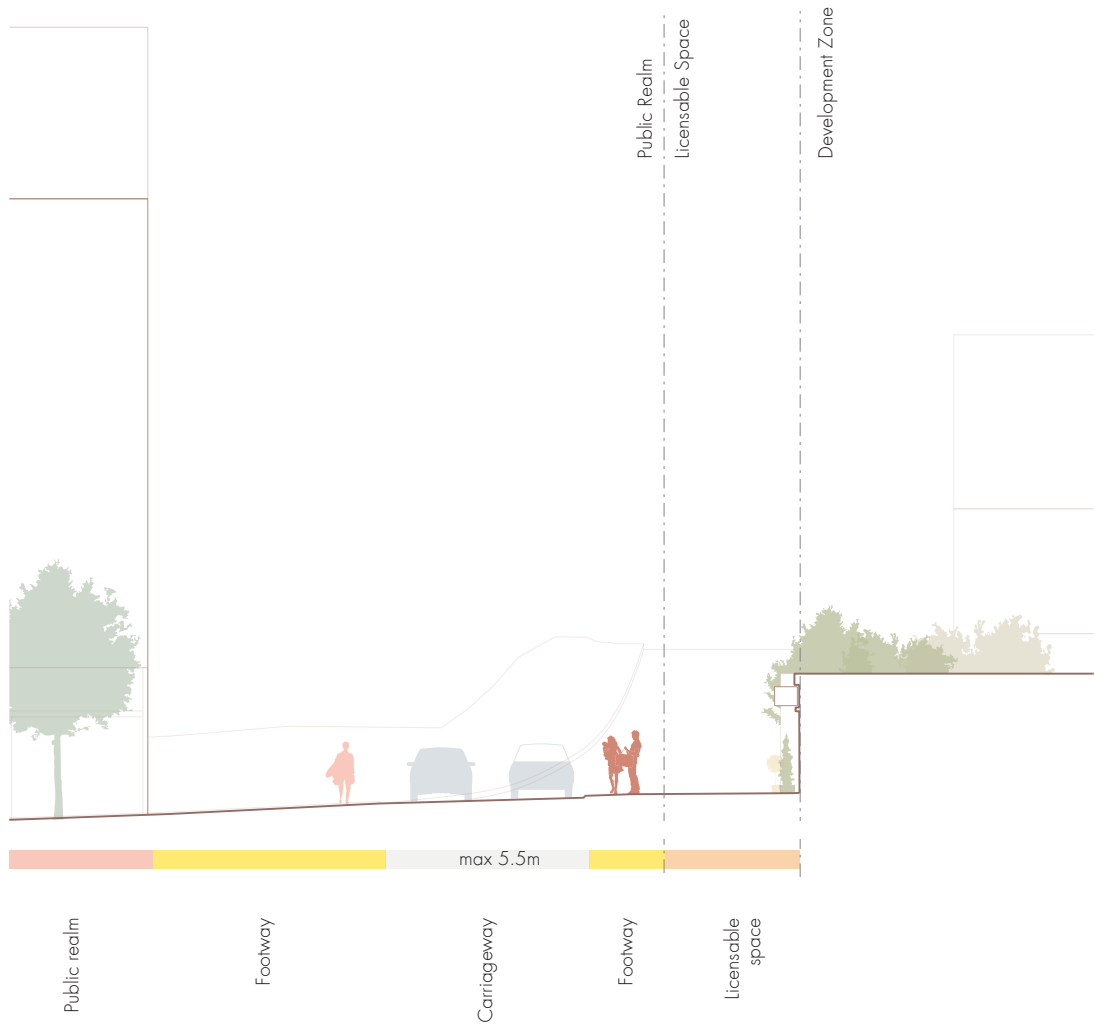
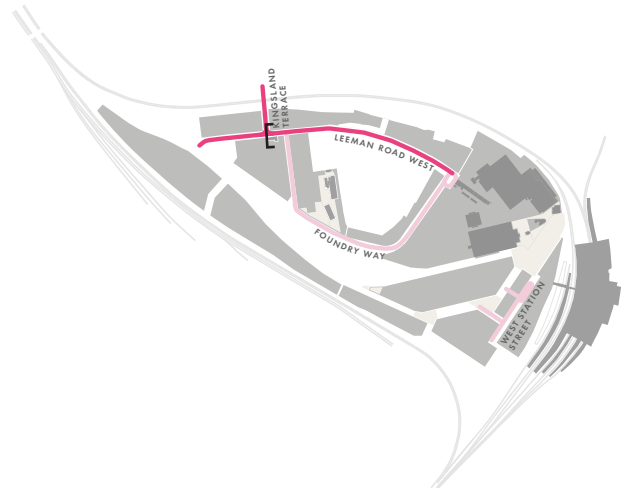

Fig.171 Illustrative section through Foundry Square showing proposed relationship with existing building

#### 4.6.5 Leeman Road West: Section showing no build zone

Where there are Townscape considerations which preclude building in certain areas of the site (see Chapter 02: Heights, Massing and Levels), these spaces should be used to positively contribute to the streetscape either as residents gardens, community gardens, play areas, skate parks or 'teen trail' leisure areas.

**In all cases, where a residence is adjacent to a play space or leisure space buildings habitable rooms shall be set back by a minimum of 10m.**

Refer to chapter 02: Building Heights Levels and Massing

#### 4.6.6 Leeman Road West: Section onto St Peters Quarter



Fig.172 02: Illustrative section opposite to St. Peter's quarter showing no build zone

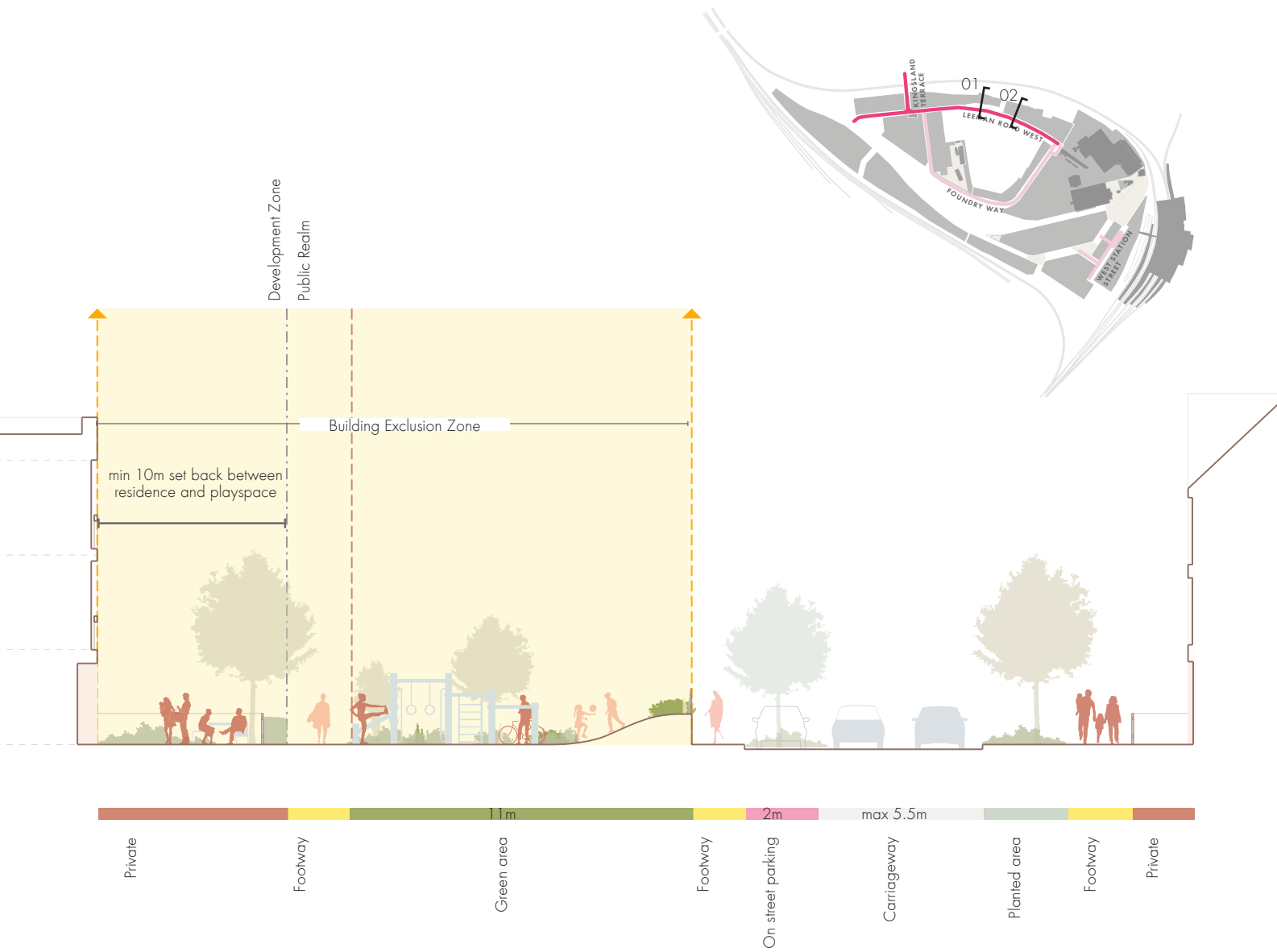
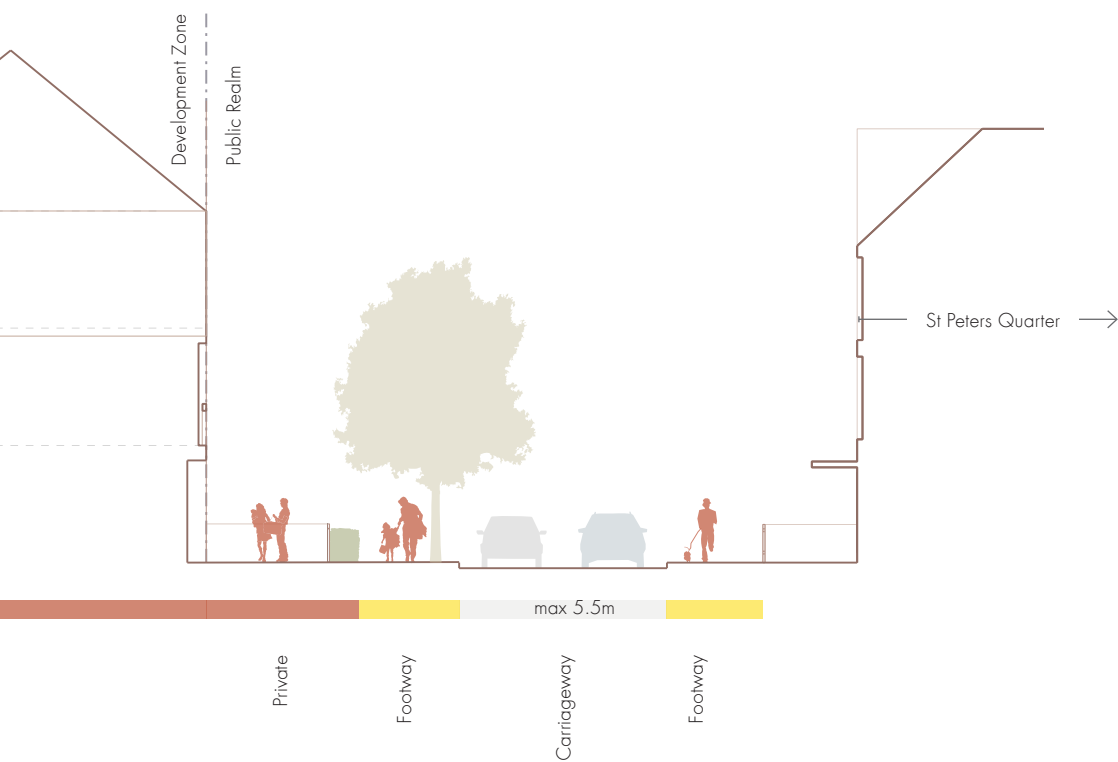
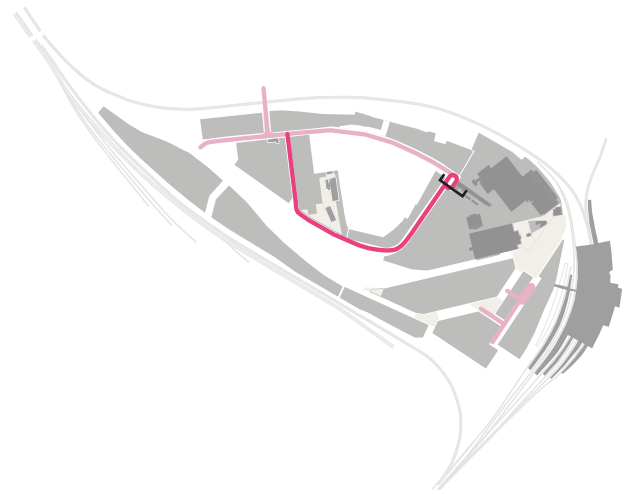

Fig.173 01: Illustrative section showing building exclusion zone





#### 4.6.7 National Railway Museum Access and Delivery

The National Railway Museum proposals will seek to maximise permeability of the site for pedestrian access whilst maintaining security for the site.

In addition to the guidelines set out in the preceding pages the following requirements shall be met:

**Access and egress from the National Railway Museum for delivery and maintenance access must be incorporated into the road design.**



Fig.174 Illustrative section showing level access to the National Railway Museum

### 4.6.8 Foundry Way

Foundry Way must include an unbroken line of street trees on the footway closest to the park.

Where on street parking is provided the carriageway width shall narrow to a minimum of 3.7m

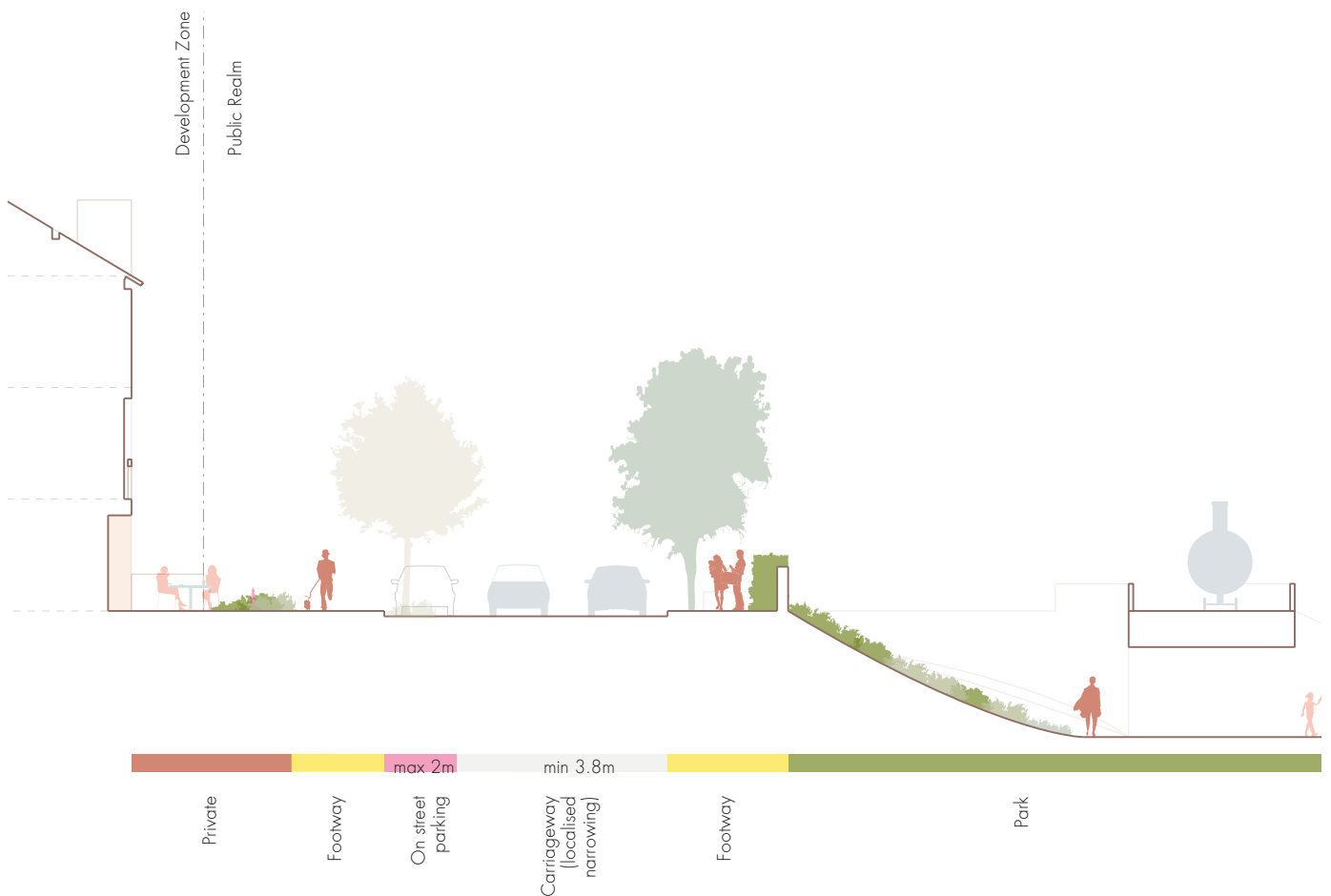
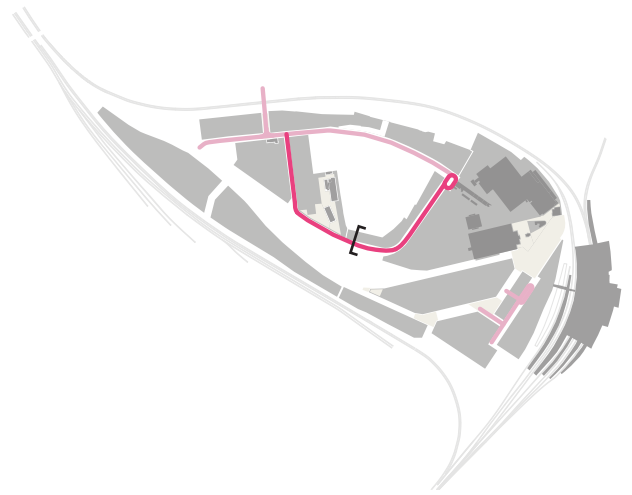

Fig.175 Illustrative section showing residential building facing the street and the Park

## 4.7 TERTIARY STREETS

**Tertiary streets run through neighbourhoods and connect homes and businesses to the primary and secondary street network. These streets may be through routes or for access only. Tertiary streets should feel intimate in scale and promote interaction and social networks between neighbours and communities.**

Tertiary streets should promote pedestrian and cycle priority. These streets might include 'Mews Typologies' see Chapter 05 and may be reduced to a minimum of 12m wide - back to front or front to front, where window arrangements are designed to overcome any overlooking issues.

**The design of tertiary streets must encourage low vehicular speed appropriate to the local environment and promote pedestrian and cyclist connectivity.** Along tertiary streets the provision of dedicated walking routes will be subject to consideration of the likely volumes, speeds and composition of traffic likely to be using the link.

Where a tertiary street forms a rear access to a property or properties, principles of Crime Prevention Through Environmental Design (CPTED) should be considered.

**Tertiary streets shall be designed to allow access for emergency vehicles.**

**The carriageway shall be a maximum width of 5m.**

**Some limited and controlled on street parking shall be permitted appropriate to the needs of the residents. Where this occurs, to encourage low vehicle speeds, the carriageway shall narrow (minimum width 3.7m). No more than four parking bays shall be placed together before they are broken by a soft landscape zone or street tree.**



Fig.176 Site plan showing tertiary streets on illustrative scheme



Fig.177 Dujardin Mews, London



Fig.179 St Johns Hill, Clapham



Fig.178 Harvard Gardens, London



Fig.180 Accordia, Cambridge

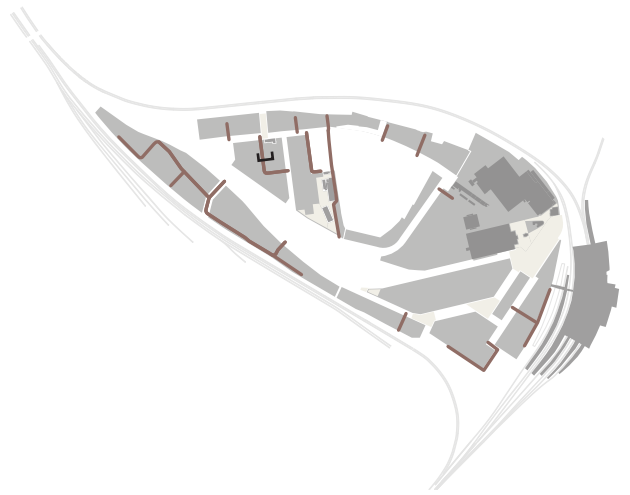

#### 4.7.1 Foundry Village: Cycle route into Park

This route is expected to be heavily used by cycles as it aligns with one of the key cycle routes into Central Park.

In addition to the guidelines set out in the preceding pages the following requirements shall be met:

**Residences shall be set back by a minimum distance of 6m from the cycle route**

**A landscape buffer zone shall be provided between residences and the cycle route.**

**Footways shall be provided on both sides of the cycle route.**

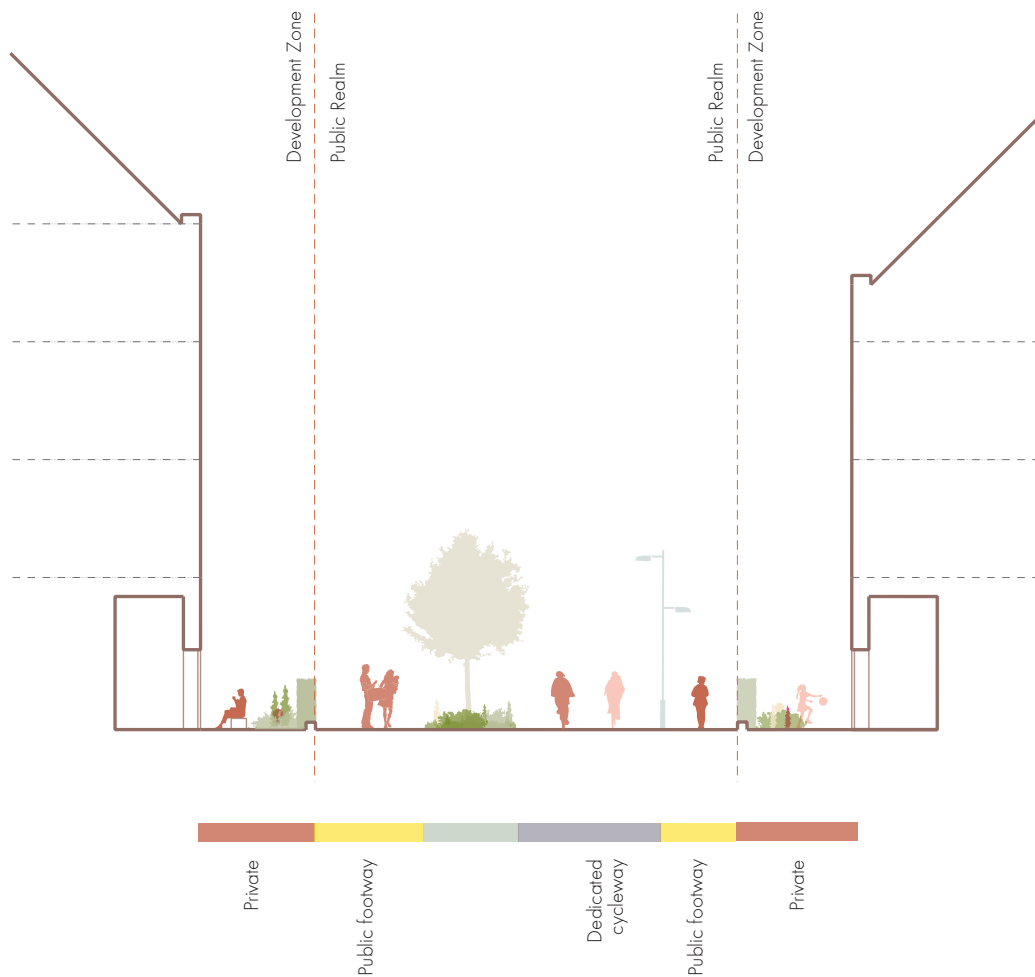

Fig.181 Illustrative section through residences and dedicated cycleway



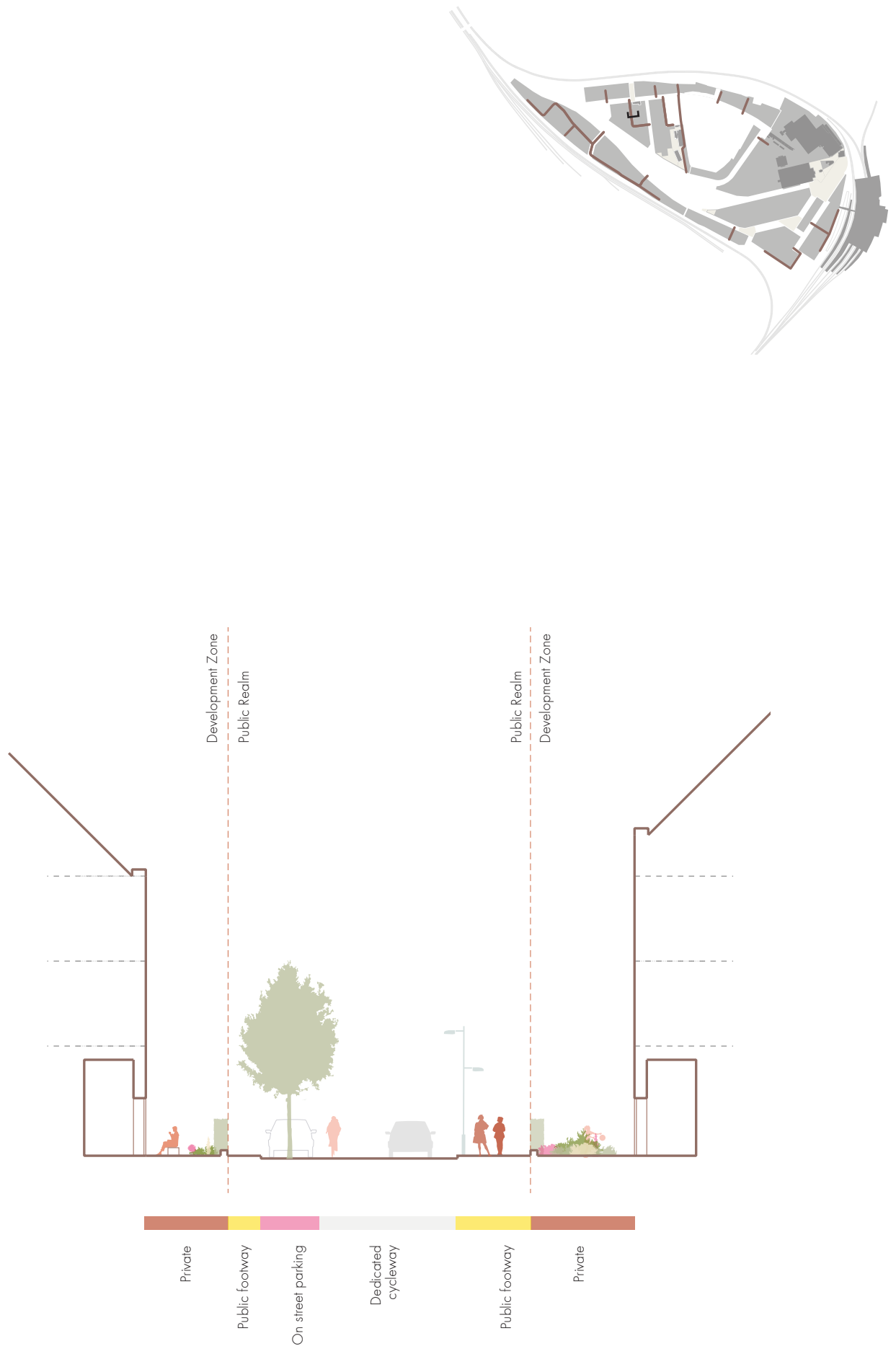
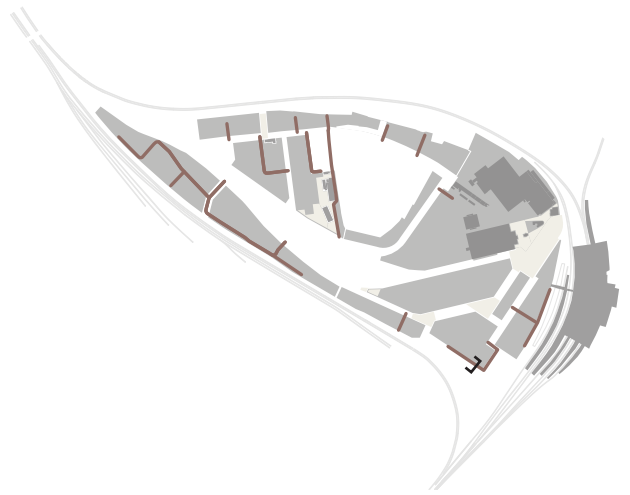

Fig.182 Illustrative section through residences and tertiary street (cycleway joins carriageway)



#### 4.7.2 Station Quarter access to the Railway Operating Centre (ROC)

**Pedestrian and vehicular access must be maintained to the ROC premises.**

This route is an important connection to established business on the existing site and to new residences facing the southern site perimeter.

**Any street proposals shall be designed to make a positive contribution to the access and egress experience to this premises.**

**Street trees and/or soft landscape planting shall be provided at regular intervals along this route.**

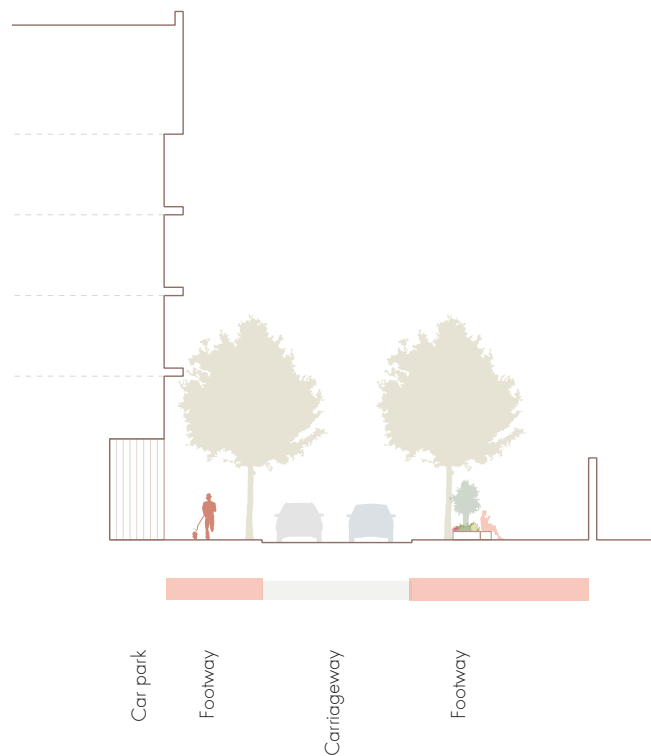

Fig.183 Illustrative section through car park and ROC

### 4.7.3 Station Quarter access road adjacent to station

The access road that borders the station lies along one of the most visible aspects of the site and as such it forms an important streetscape and elevation to the site.

A portion of this land is safeguarded for future rail capacity schemes at the station. 'Meanwhile uses' will be required in this area in the early phases of the scheme.

**Any proposals shall be designed to make a positive contribution to the aspect of the site from the station platforms.**

**Street trees and/or soft landscape planting shall be provided at regular intervals along this route.**



Fig.184 Illustrative section through access road adjacent to station



#### 4.7.4 Carlisle Street

A Mews typology that is intimate in scale is strongly encouraged along this street.

Bays of buildings may overhang the public realm.

In addition to the guidelines set out in the preceding pages the following requirements shall be met:

**The proposal for Carlisle Street must be cognisant of the existing buildings.**



Fig.185 Illustrative section showing a possible arrangement for a mews typology on Carlisle Street

#### 4.7.5 York Yard South

In addition to the guidelines set out in the preceding pages the following requirements shall be met:

**Where access roads run immediately adjacent to the site perimeter a landscape buffer zone of minimum 5m shall be provided see 'Site Perimeter' Chapter 03.**

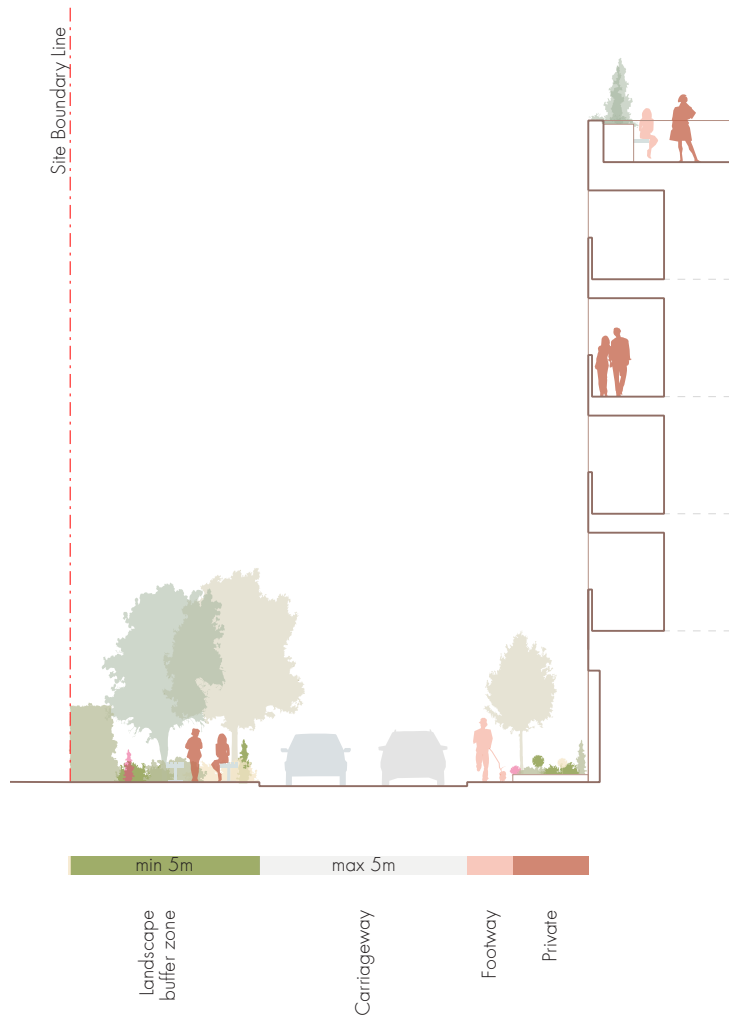
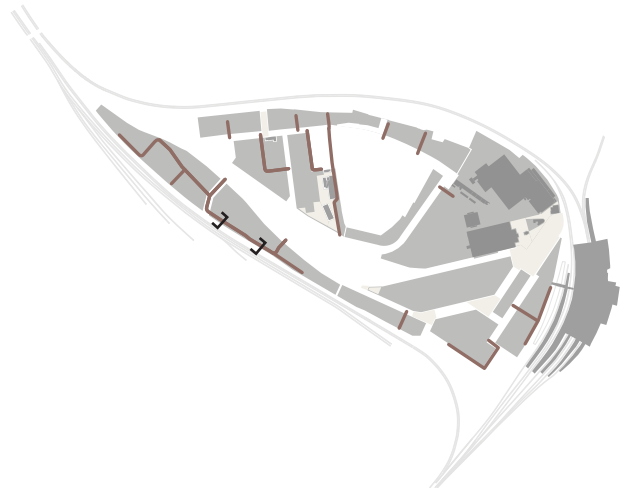

Fig.186 Illustrative section showing building adjacent to roadway

## 4.8 FOOT STREETS

To promote sustainable means of travel and pedestrian connectivity, York Central will add to the city's existing network of Foot streets and provide a framework of dedicated pedestrian routes between key public spaces within the site. These are intended to provide convenient and direct routes for pedestrians within the development site and to help foster a sense of place and community.

York has one of the largest pedestrian zones in Europe. Many areas within York city centre are designated as pedestrian foot streets, with restrictions to vehicle access between certain times of day or 24 hours.

It is intended that the York Central site adds to this network and contributes to the pedestrian connectivity through the city.

**Foot streets shall be designed to be pedestrian priority spaces.**

**The material palette selected in the design of foot streets shall be cognisant of the visual perception and comfort of pedestrians.**

**Where vehicle access is required material selection shall be appropriate to allow the anticipated passage of vehicles.**

**Cycling shall be permitted in all foot streets.**

**No road marking shall be permissible.**



Fig.187 Site plan showing foot streets, play streets and snickets in illustrative scheme



Fig.188 Pavilion Road, London



Fig.189 New Road, Brighton



Fig.190 Kensington Street, Sydney



Fig.191 Low Peter Gate, York

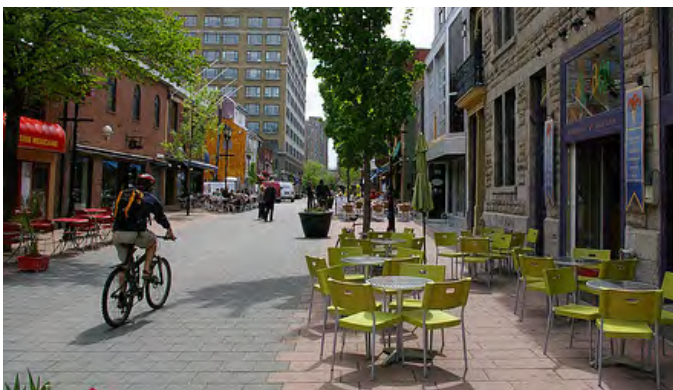

Fig.192 Woonerf street, Netherlands



Fig.193 Pedestrianised street, Buenos Aires

#### 4.8.1 Hudson Boulevard

Hudson Boulevard is intended as a wide open pedestrian street planted with trees and populated with pedestrians, and people sitting out in cafés/restaurants/retail.

This street forms a key edge to the park and will also provide a route for the passage of trains for display within New Square.

In addition to the guidelines set out in the preceding pages the following requirements shall be met:

**Hudson Boulevard shall require access to vehicles to service adjacent buildings. This shall be restricted to certain times of day.**

**A dedicated cycleway shall be provided.**

**The surface treatment and landscape strategy must be appropriate for use by vehicular traffic (service, maintenance and delivery only).**

**Hudson Boulevard shall include rail tracks which facilitate the exhibition of trains in Museum Gateway.**

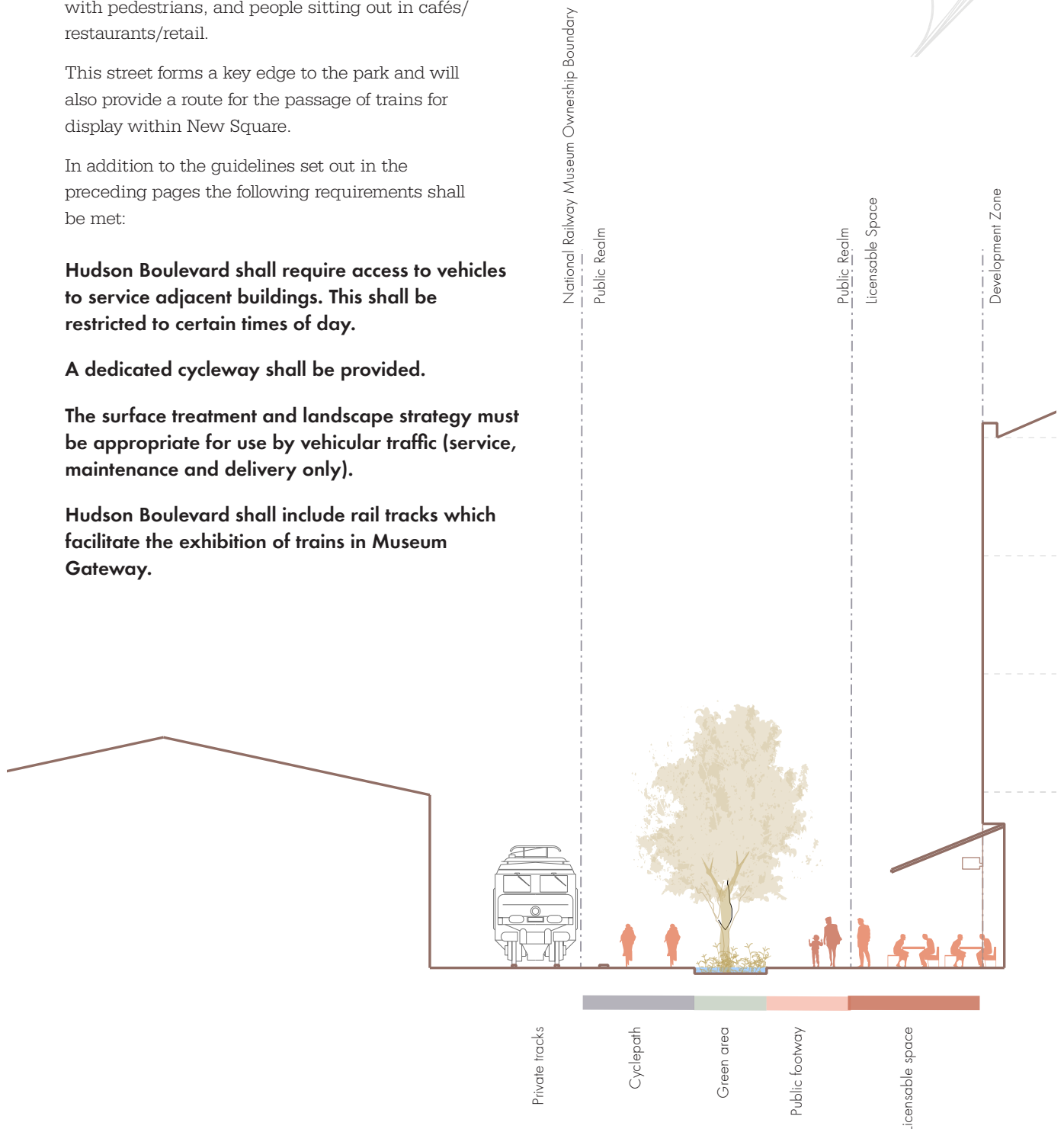

Fig.194 Hudson Boulevard: Illustrative section showing commercial ground floor with seating area, facing onto National Railway Museum and park with dedicated cycle lane



**4.8.2 Cinder Lane and Hudson Lane**

Cinder and Hudson Lane are intended as small scale streets which provide passage between Hudson Boulevard and Cinder Street. Additionally, they provide service access to the buildings around the Cinder Yards.



In addition to the guidelines set out in the preceding pages the following requirements shall be met:

**Maximum width of 18m**

**Vehicles access shall be restricted to certain times of day and limited to the minimum possible portion of the streets length to be agreed with the CYC.**

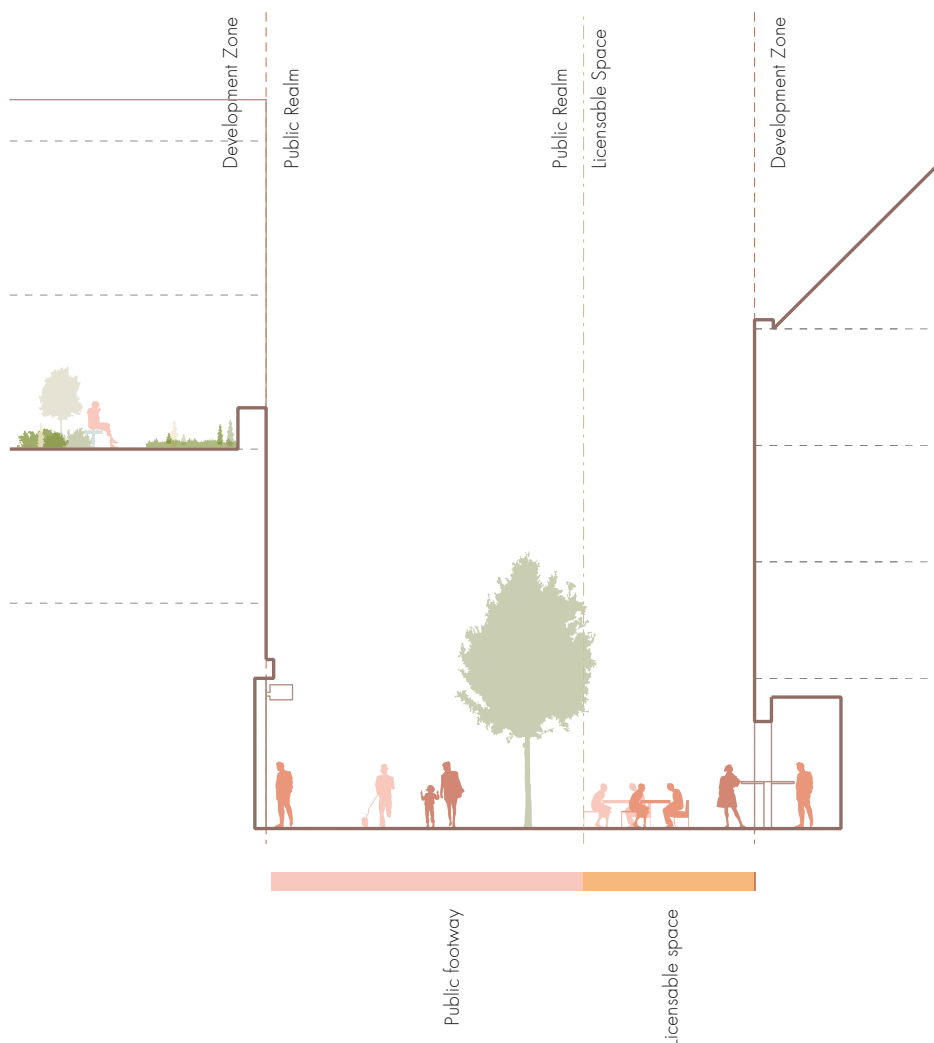

Fig.195 Cinder Lane/Hudson Lane: Illustrative section showing pedestrian route



### 4.8.3 New Square: Coal Drop Boulevard

In addition to the guidelines set out in the preceding pages the following requirements shall be met:

**Minimum public pedestrian zone 5m between Coal Drop edge and building lines.**

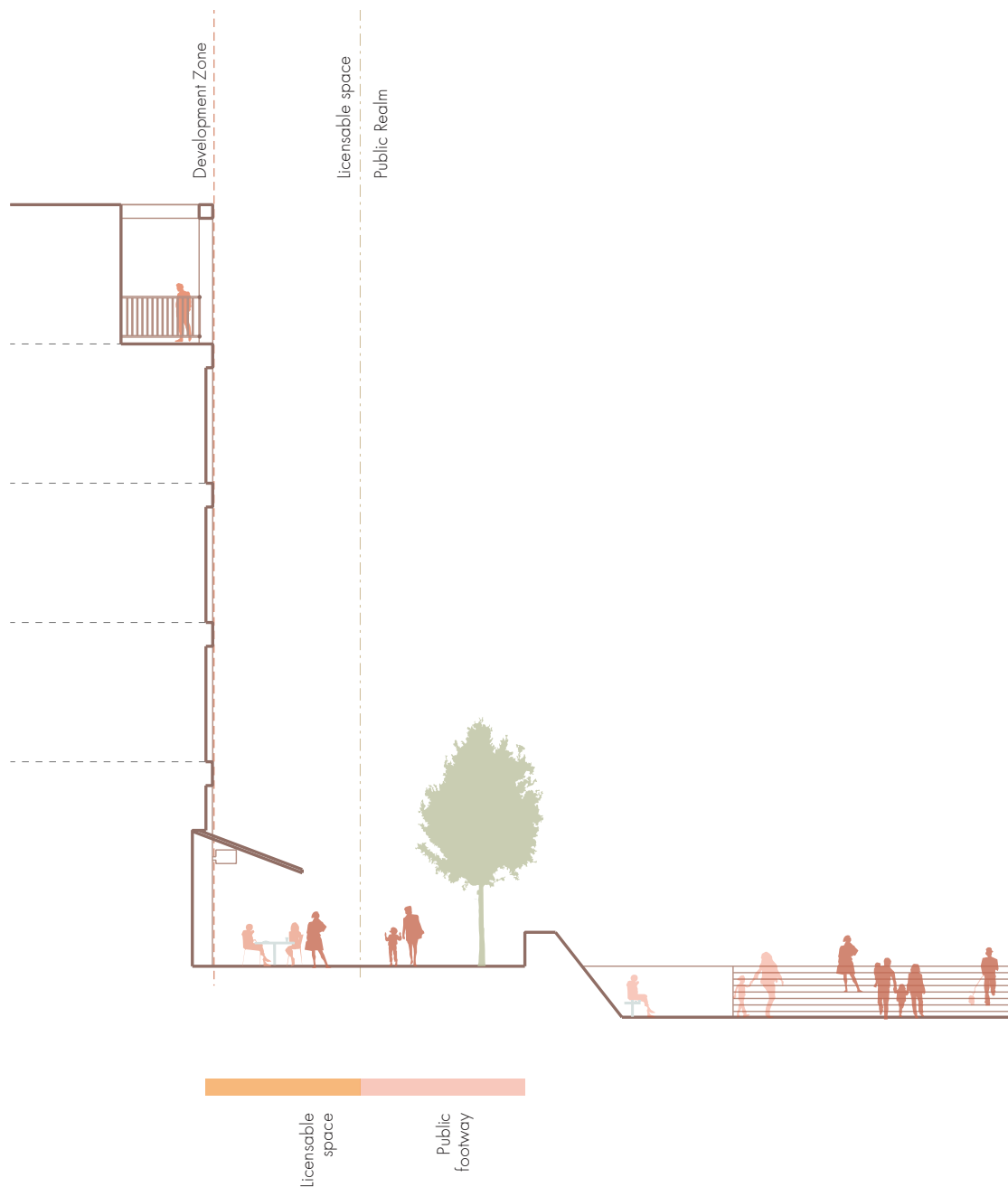

Fig.196 Illustrative section showing pedestrian boulevard adjacent to the Coal Drops

**4.8.4 Foundry Way: Mansion Block Facing onto Reeds Garden**

In addition to the guidelines set out in the preceding pages the following requirements shall be met:

**Vehicle access shall not be permitted.**

**Landscape screening shall be required between the residences and main public park.**

The inclusion of a residents footway is encouraged. This should not be gated but made to feel 'private' through the scale and treatment of the route.

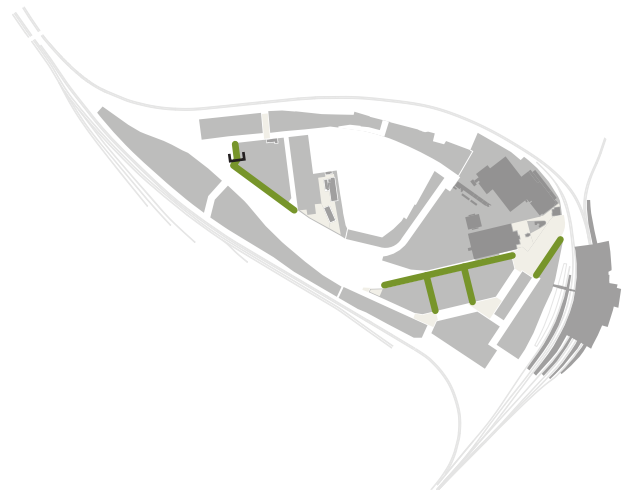

Fig.197 Accordia, Cambridge

Fig.199 Accordia, Cambridge

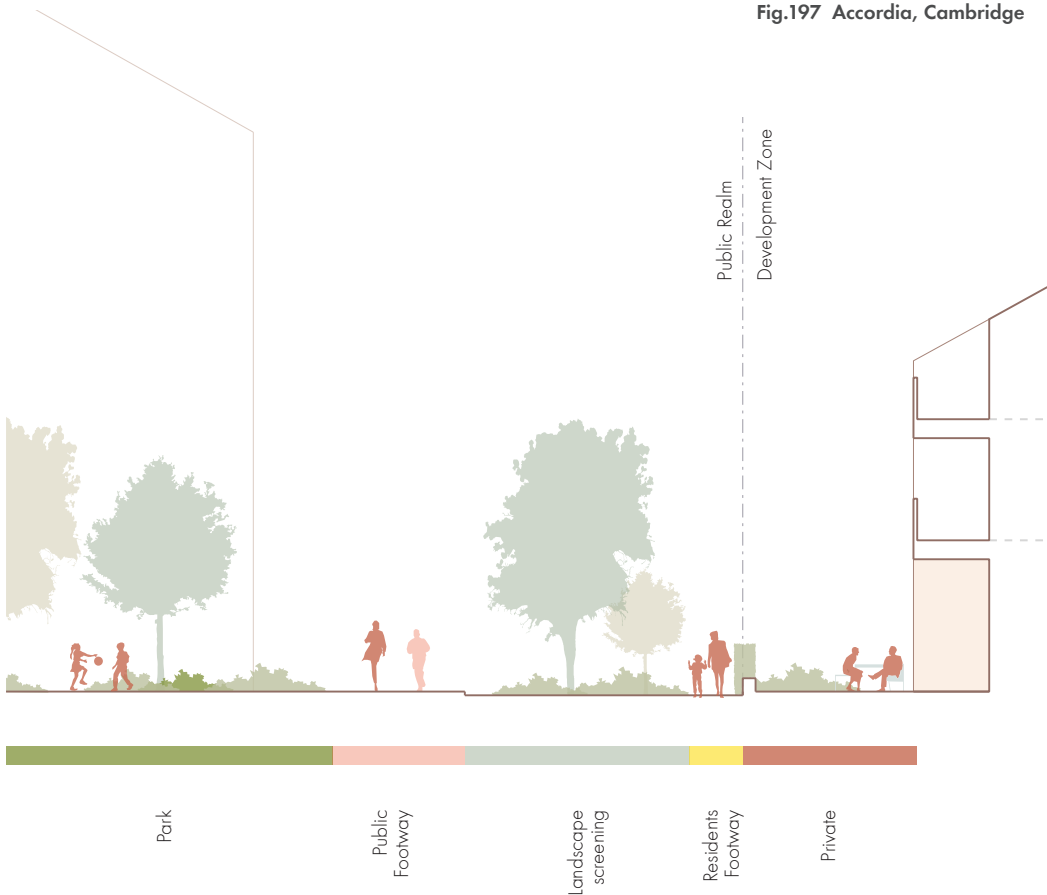

Fig.198 Illustrative section showing 19.5 m street residential terraced block housing (on plot parking) to retail ground floor use

## 4.9 PLAY STREETS

**Design for play is an important component of a human centred approach to the design of streets. A child friendly environment is a vital part of creating inclusive cities that work for everyone. Play streets are part of the site wide approach to play which is designed to support children to get around independently, have a strong contact with nature, and to grow up in a healthy and happy environment with lots of opportunities for play. Play streets should also be inclusive of adults and teens and designed to foster inclusive communities through the integration of community gardens, food growing spaces and nature or fitness**

---

A number of play streets are proposed within the site in the Foundry Village, York Yard South and Station Quarter. These spaces are intended to be used by the residential community of York Central and provide a safe environment, where children of various ages can play. The spaces should include a component of community use such as allotment gardens or communal growing spaces and include areas which appeal to teenagers e.g. fitness equipment.

The design of each play street must contribute to the place making of the area. These should incorporate soft landscaping features and opportunities for children to engage with nature, with space explicitly given over to 'nature play' which could be combined with neighbourhood gardens or vegetable patches. It is intended that the play streets act as 'green fingers' of space which connect the residential neighbourhoods to the Central Park. A play street shall be provided within each of the following Development Zones: M, J and E.

**Play streets shall be car free with no car parking.**

**Play streets shall be designed to include areas which appeal to various age groups of children and teens.**

**Play areas shall be fully accessible between dawn and dusk.**

**Play areas shall not be situated at the rear of dwellings.**

**Play streets must include a significant component of soft landscape and 'nature play'.**

**Play streets should be designed flexibly to allow for any significant change within the local demographic of a community e.g. if residential blocks are approved for a change of use to be a retirement community the play space may be modified to grant additional space for the neighbourhood garden component of the street.**

**Each play street shall be designed to have different landscape characters and different activities on offer.**



Fig.200 Fitness trail play



Fig.202 Playground, Amsterdam



Fig.201 Beuningenplein Playground, Amsterdam



Fig.203 Wakenwerksplaats, Amsterdam



Fig.204 Handyside Gardens, London

#### 4.9.1 Play Street

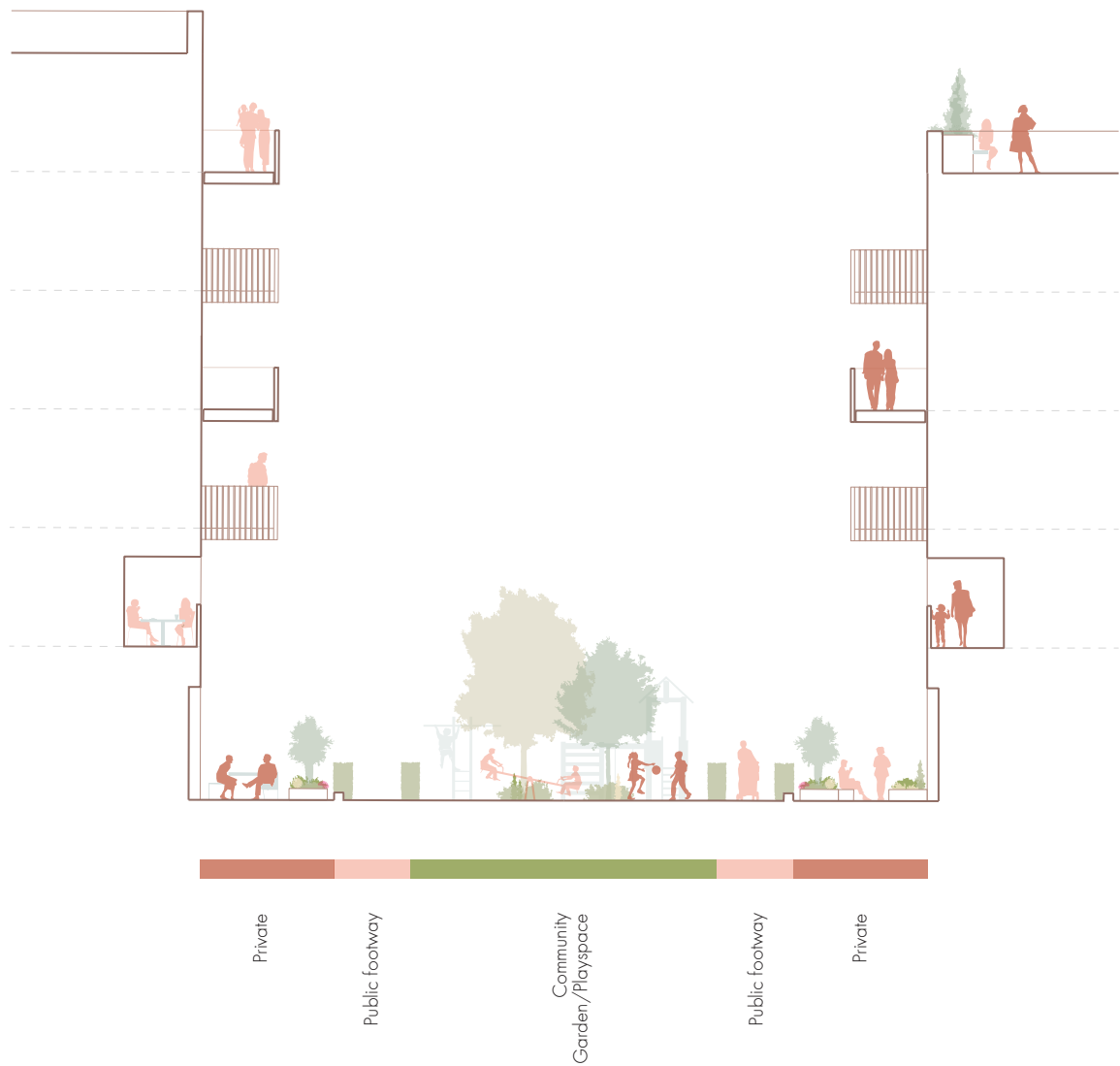

Fig.205 Illustrative section showing a typical playground between two residential blocks

4.9.2 Illustrative playstreet plan

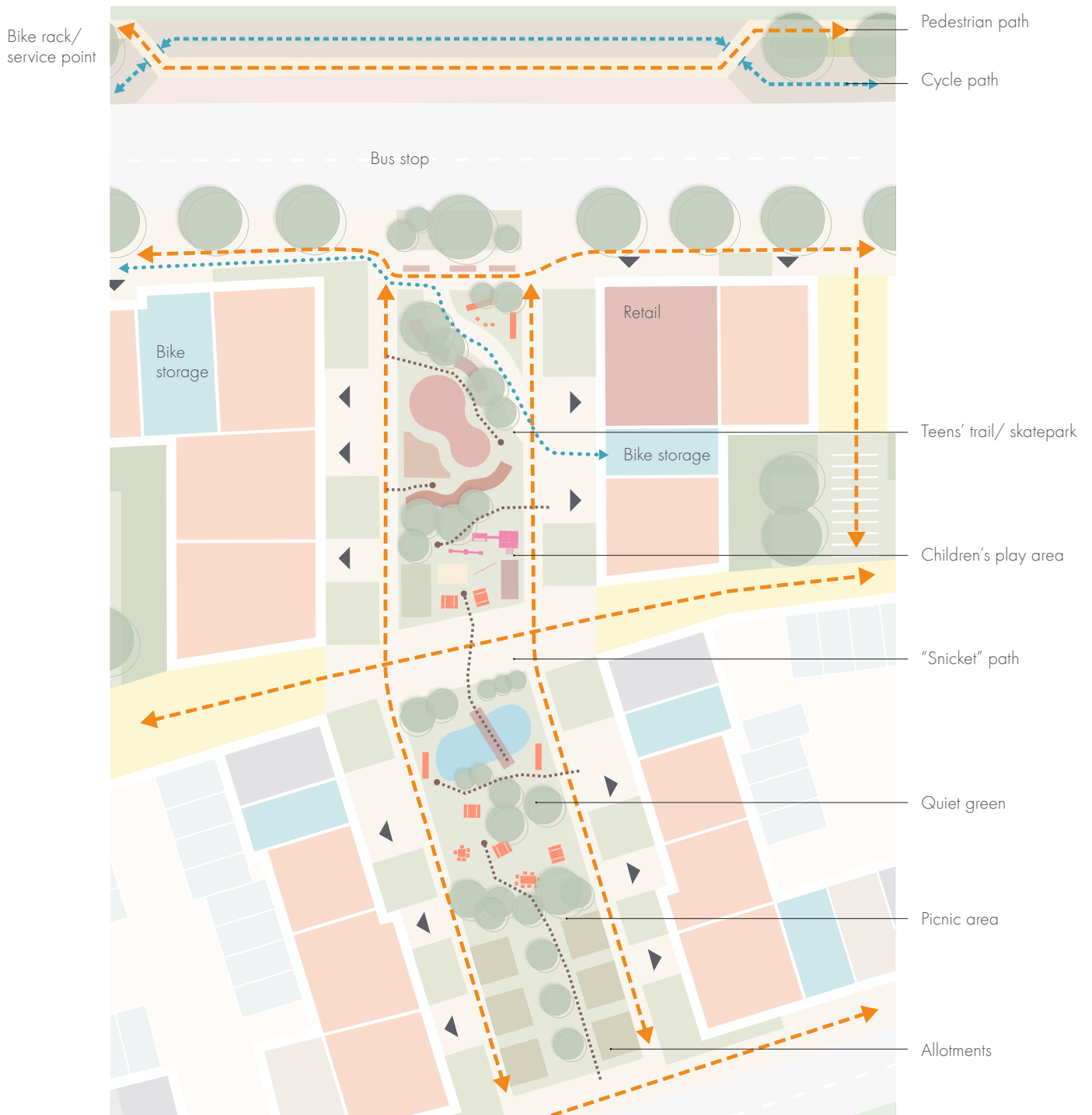

Fig.206 Illustrative plan of a typical play street

## 4.10 SNICKETS

**Part of the unique character of the existing street scape of York is the network of alleyways and passages - 'snickets'- between buildings and fences that allow pedestrians to easily and directly traverse the city's streets. The 'snicket' streets of York Central should be connected in the same way and continue this interconnectivity.**

---

The numerous existing snickets in York provide different functions connecting parallel streets, providing access to building entrances or side access and light. They may be open to the sky, covered, or partially covered.

The snickets are intended to provide improved pedestrian connectivity between streets and blocks and provide a choice of journey for workers, visitors and residents.

Snickets may be public, semi-public/private, or residents only but should be overtly characterised by their human scale and intimate nature.

Snickets should only be included in the design of streets and building arrangements where they perform a genuine function within a street or community.

Principles of Crime Prevention Through Environmental Design (CPTED) should be considered. Gates should be provided where a snicket forms a rear access to a group of houses and/or gardens.

They should have a clear line of sight from beginning to end and be overlooked where possible with a gable end window or window.

**Snickets must provide a convenient and direct pedestrian connection between or through a block, following pedestrian desire lines.**

**Snickets have a minimum width of 1.5m**

**Vehicles shall not be permitted.**

**Where snickets pass through private, semi-public/private areas consideration shall be given to security and crime prevention.**





Fig.207 Dujardin Mews, London



Fig.209 Lady Pecketts Yard



Fig.208 St Johns Hill, Clapham



Fig.210 Norman Court



Fig.211 Coffee Yard



Fig.212 gated snicket

## 4.11 ROAD CROSSINGS

Pedestrian crossing points shall be provided based on pedestrian desire lines. These shall generally take the form of “courtesy crossings” unless traffic and pedestrian flow determines that a more formalised crossing arrangement is required. e.g between Station Gateway and Museum Gateway.

‘Courtesy crossings’ are uncontrolled crossings without signals which rely on vehicles slowing down to let pedestrians cross.

Crossings shall be demarcated by a change in surface material see “4.14 Material palette” or as a public art feature.

The location of crossing points may be combined with localised narrowing of the carriageway to reduce the crossing distance for pedestrians and to encourage a reduction in vehicle speed on the approach to the crossing point. On Park Street, crossings should be a minimum width of 3.0m.

Where crossing is required through a planted median the soft planting shall stop and a change of surface introduced that facilitates safe pedestrian crossing.

Dropped kerbs shall be provided at crossing points along with tactile “blister” paving to demarcate crossing points for the visually impaired.



Fig.213 Pedestrian crossings demarcated with a public art feature



Fig.214 Courtesy crossing with change of surface material

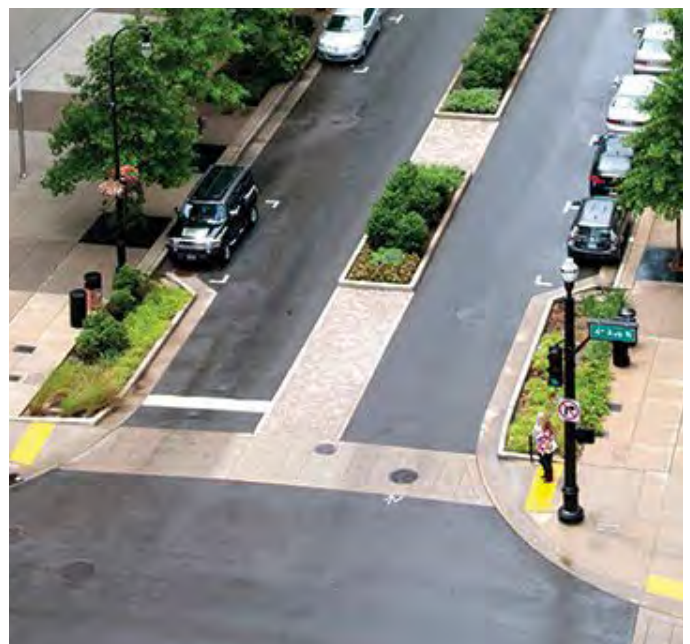

Fig.215 Courtesy crossing within planted medians

## 4.12 ROAD AND RAILWAY CROSSING POINTS

Where the National Railway Museum access line crosses the proposed Leeman Road carriageway, a crossing point shall be provided. This shall take the form of embedded rail within the adopted public highway.

Measures to secure the safe passage of rail locomotives and rolling stock shall be established through provision of gates which can be closed across the carriageway, footways and cycleways.

These shall respond sensitively to the site and be contemporary in their form.

When not in use, these crossing points will allow the unimpeded flow of pedestrians, cyclists and vehicles, with the alignment of the embedded rail oriented perpendicular, or near perpendicular, to the direction of highway movement to reduce the risk of wheel slip or cyclists' wheels becoming caught between the rail and adjoining surfacing.

When the access line is in use, the crossing point will be marshalled by National Railway Museum staff.



Fig.216 Embedded tracks within public highway



Fig.217 Train on route to 'Deutsche Technikmuseum' via Park am Gleisdreieck, Berlin



Fig.218 Tracks set into park landscape Park am Gleisdreieck, Berlin

## 4.13 STREET TREE FRAMEWORK

**Streets trees are an integral component of the green infrastructure of urban development and provide a wide range of benefits to their surroundings; most importantly improving the health and quality of life of those that live, work and visit York Central.2**

**On the north/south and west/east green corridors (refer to “3.2 Ecology”) street trees shall be planted in combination with hedgerow to provide ecological permeability throughout the wider site.**

Areas of rough grassland adjacent to the hedgerow will provide an additional habitat, creating a mosaic that is favourable to invertebrates and foraging birds.

Street tree species shall be selected to provide seasonal interest, colour, texture and form at different times of the year.

Different placement and styles of planting shall be used to complement the character of the street. Some streets should have uniform planting with trees planted at regular intervals matched on both sides (e.g. streets located on Southern side of York Central) while other streets should have irregular tree planting on both sides along their entire length (e.g. streets located on the northern side of York Central).

Adequate space between trees and street lights and signage should be allowed for to ensure that future growth will not impede their beam and sighting.

The positioning of a tree in the proximity of buildings should consider and allow crown growth and for its natural movement in windy conditions.

Trees in Park Street shall be used for traffic calming: highlighting intersections, reducing physical and optical width, but not obstructing sight lines to pedestrian crossing points.

The different root systems of trees shall be considered. Trees with invasive root systems, such as Populus (Poplar or Aspen), or Salix (Willow) should not be planted in streets.

In selecting tree species, priority shall be given to wildlife friendly UK native species that require less maintenance and irrigation.

**The design shall aspire to implement the best practice guidance set out in “Trees in Hard Landscapes” published by Trees & Design Action Group.**



**Fig.219 Beckfield Ln, York where trees are used to complement the character of the street**

## 4.14 MATERIAL PALETTE

The York Central material selection is to comprise four distinct yet complementary palettes corresponding to the development's character areas and street hierarchy, with the overall look and feel of each to comply with the requirements set out in this guide.

Public realm material shall complement the character of the buildings as set out in chapter 08 Typologies and 06/07 Appearance.

Materials shall be selected according to the following:

- Fitness for purpose
- Consistency of use across the site
- Ease of maintenance and replacement
- Sustainable sourcing
- Efficiency and sustainability
- Embodied energy over the full lifespan of the product
- Durability
- Design life cycle impact
- Capacity for re-use or recycling
- All materials shall comply with CYC specifications.

All adopted roads shall comply with CYC standards and requirements as a minimum. All materials in this area shall be approved by the CYC.



Fig.220 Diagram showing site wide material strategy

#### 4.14.1 Civic Palette

The Civic palette is to be used in the New Square, and is comprised predominantly of hard surfaces.

The use of natural stones is strongly recommended (i.e. Yorkstone, granite, basalt) and should tie into the overall design language of the particular areas in which they are used. Within the Coal Drops area, the use of black basalt is strongly encouraged, so as to evoke a sense of the area's historical use and railway heritage.

It is recommended to use stone setts as paving for the carriageway.

Channel drains shall be discreet and well integrated with the surrounding paving areas.



Basalt black setts

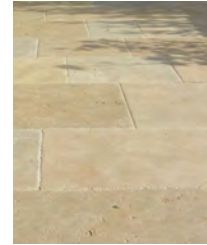

Yorkstone flags



Rail edge integration

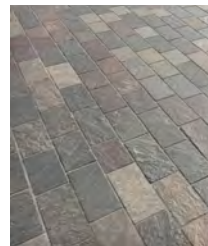

Granite setts



Yorkstone tree pit setts

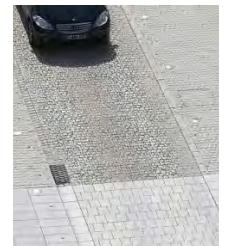

Use of stone setts on a carriageway

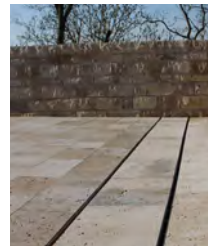

Slot drains



Bespoke channel drain made of stone

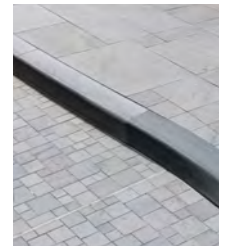

Stone raised kerb

#### 4.14.2 Primary Palette (A & B)

Materials should be selected and arranged in order to clearly distinguish the hierarchical relevance of these areas in relation to the wider streetscape character.

Materials must allow for a wide range of variation in the size of units or elements, finishes and colours (e.g. in-situ concrete with exposed aggregates, resin bound gravel, tar and chip and bitmac surfacing).

Materials must be robust and provide good slip resistance and compressive strength, ensuring they will be appropriate for vehicle traffic areas as well as pedestrian pavements.

Pavements for heavier vehicular usage, such as carriageways should be paved with hot rolled asphalt (in accordance with the relevant Highway standards) with stone gutters and kerbs.



Recycled paving units



Exposed aggregates



Tar and chip



In-situ concrete with exposed aggregate

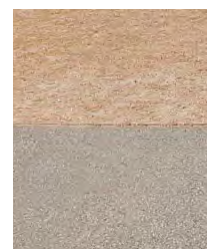

Self bound gravel used in combination with in situ concrete



Hot rolled asphalt

### Primary Palette A

The Primary palette A is to be applied in the main connective spine road (Park street), Park Plaza, Hudson Boulevard and Station Quarter.

The following materials should be used in this area: in-situ concrete with exposed aggregates, resin bound gravel, tar and chip and bitmac surfacing.

### Primary Palette B (Foundry Yard palette)

The Primary palette B is to be applied in the Foundry Yard.

The following materials should be used in this area: self-binding gravel and in-situ concrete

The use of recycled materials is encouraged in this area

#### 4.14.3 Residential Palette ( A & B)

Durability and low maintenance shall be a key consideration informing material selection.

All materials shall be robust and provide good slip resistance and compressive strength, ensuring they will be appropriate for vehicle trafficked areas as well as pedestrian pavements.

Materials shall allow for a wide range of variation in the size of units or elements, finishes and colours (e.g. precast concrete units, resin bound gravel and bitmac surfacing).

Pavements for heavier vehicular usage, such as carriageways should be paved with hot rolled asphalt (in accordance with the relevant Highway standards).

Wet pour rubber surfacing shall be used in the formal playground areas or other suitable equivalent.

Resin bound gravel shall be used for the segregated cycleways in order to tie in with the materiality of the park



Bespoke precast concrete units

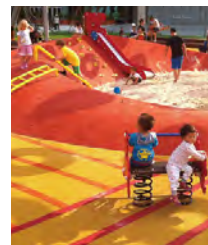

Wet pour rubber surfacing



Resin bound gravel



Precast concrete - small units

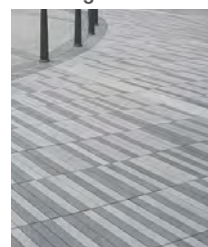

Precast concrete - small units

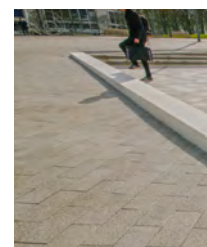

Precast concrete - large units

#### Residential Palette A

The residential palette A is to be applied in areas such as Leeman Road West and Foundry Way.

Large pre-cast units should be used in all footways within this area in order to clearly distinguish the hierarchical relevance of these areas in relation to the wider streetscape character.

#### Residential Palette B

The residential palette B is to be applied in areas such as Foundry Village, Foundry Terrace, Leeman Yard and York Yard South.

Residential B is composed of the same materials as Residential Palette A but requires smaller unit sizes to reflect the more intimate nature of the streets and building typologies of the different character areas they are in.

### 4.14.4 Park Palette

**The park palette is comprised predominantly of softscaping.**

Materials should be characterised by permeability, low maintenance and limited impact on the quality of the natural environment (e.g. resin bound gravel, self-binding gravel).

The use of resin is recommended bound gravel is recommended on the main footpaths (including cycleways) and self binding gravel on the secondary footpaths.

Where appropriate, materials shall integrate or establish a relationship with the railway heritage present on site (i.e. ballast, railway lines).

Durability and sustainability shall be the key criteria informing material selection - and the use of recycled material is encouraged - in these areas.

The use of recycled materials is encouraged in this area.

Bespoke concrete or natural stone shall be used on special features



Timber bridges



Ballast



Self-binding gravel used next to seating areas



Metal Edge (recycled rails)



Special feature made with bespoke concrete units

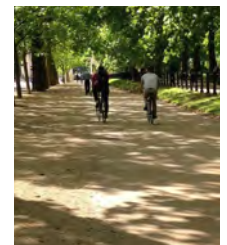

Resin bound gravel used on cycleways



## 4.15 STREET FURNITURE

Street furniture is a vital component of usable streetscapes and open spaces and, when strategically sited and comprising well-chosen materials, it enhances and complements the spaces in which it is located. Street furniture inspired by the site's pre-rail and railway heritage, and the skill, craft and mechanical production associated with this, is encouraged.

### 4.15.1 Street Furniture

The following principles shall be observed when developing the street furniture strategy and character:

Street furniture shall comply with relevant standards and requirements in order to ensure users' health and safety.

The design of street furniture shall consistently reflect the hierarchy of streets and open spaces, as set out on page 4.1 "Street hierarchy".

Street furniture shall respond to the particular identity of each neighbourhood, enhancing each area's urban and landscape characters to reinforce its sense of place and create comfortable and pleasant environments.

The use of recycled site materials in the design of street furniture is encouraged.

The materiality of street furniture shall respond to the site's railway heritage.



Fig.221 Cycle Stand precedents



Fig.222 Bench precedents



Fig.223 Litter bin precedent



Fig.224 Recycling bin

## 4.16 LIGHTING

**Lighting is to be utilised to enhance York Central’s architectural features and provide visual comfort while helping to create spaces that are inspiring and adaptable. A well-integrated lighting design will be crucial to providing safe places for pedestrians and cyclists while minimising unnecessary light pollution.**

---

The following principles shall be observed when developing the lighting strategy and character:

The lighting design shall ensure sufficient light levels so as to safely light pedestrian and vehicular trafficked areas, whilst minimising light spillage.

Bollard lighting should be avoided on major routes as it does not project sufficient light at the right height and distorts the available light due to the ‘up-lighting’ effect; making it difficult to recognise facial features and as a result causes an increase in the fear of crime.

The use of lighting in ecological habitat zones (refer “3.2 Ecology strategy”) shall be limited to areas where it is essential for safety, security or a requirement for movement of vehicles.

When designing street lighting, it is strongly recommended that advice is sought from specialist lighting consultant.

The selected lighting fixtures and design of lighting levels should consistently reflect the hierarchy of streets and open spaces, as set out in 4.1 “Street hierarchy”.

The lighting design shall respond to the particular identity of each neighbourhood, enhancing each area’s urban and landscape characters to reinforce its sense of place and create secure and pleasant environments. Lighting elements should have a sustainable life cycle and minimum impact on the environment.

Minimising potentially obtrusive light poles and other armatures within the public realm by concealing light fittings within street furniture or buildings where feasible is encouraged.

Where practicable (secondary routes), lights shall be designed to be directed at the ground or low level lighting considered as an alternative to traditional street light design.

Where streets consist of predominately Mews housing typologies, lighting should be integrated within the building design.

In addition to permanent functional and feature lighting, temporary lighting shall be considered for festivals and other temporary events. The use of theatrical lighting in the form of temporary site-specific installations is encouraged to activate the area after dark.



Fig.225 Square and civic space precedent



Fig.226 Detailed lighting element precedent



Fig.227 Streets and neighbourhood edges precedent

## 4.17 WAYFINDING

The following principles should be observed when developing the wayfinding strategy and character.

---

**Wayfinding and signage elements shall consistently reflect the hierarchy of streets and open spaces, as set out in 4.1 "Street hierarchy".**

**Wayfinding elements shall be legible and accessible to all through the use of clear and consistent graphics.**

**The scale and composition of signage shall be sympathetic to the space or building to which it relates as well as the overall character of the public realm.**

**The wayfinding strategy shall be developed to be complementary to CYC standards.**

Wayfinding should not rely exclusively on text-based signage, but utilise more information systems, including interactive signage, braille language and globally recognised iconography.

Wayfinding and signage incorporating interpretive elements that help to express the site's historical and environmental narrative are strongly encouraged.

When designing wayfinding signage it is strongly recommended that advice is sought from a specialist wayfinding consultant.



Fig.228 Street signage precedent



Fig.231 Street signage precedent



Fig.229 Public space wayfinding precedent



Fig.232 Public space wayfinding precedent



Fig.230 Public space wayfinding precedent



Fig.233 Signature element precedent



## 5 HERITAGE ASSETS

This section provides guidance for the treatment of heritage assets on the site that are proposed to be retained within the Masterplan. It provides a summary of the issues to be considered when working on or near one of these buildings, and provides guidance on conservation and adaptation. This section should be read in conjunction with the York Central Heritage Statement.

## 5.1 INTRODUCTION

**This chapter is divided into two parts - the first sections contain general guidance which applies to all retained heritage assets in York Central. The later sections cover each of the heritage assets by Character Area. The guidance on the assets includes a brief note on their significance and their potential for re-use.**

### 5.1.1 York Central

Prior to the birth of the railways, York Central was largely agricultural. The site today is largely brownfield containing a number of built structures related to the railway industry, which act as reminders of York's history as a railway manufacturing hub and centre of railway administration.

### 5.1.2 Above ground assets

Designated heritage assets within the site comprise the Goods Station (now the National Railway Museum), Weigh Office and the Gate Piers and Gates which are Grade II listed.

Non-designated heritage assets to be retained within the site include buildings associated with the railway industry. These comprise -

- Coal Manager's Office, Bullnose Building
- Former North Eastern Railway horse stables
- Albion Iron Foundry Shop
- Albion Iron Foundry Warehouse
- Albion Iron Foundry Smith's office
- York North Engine Shed (largely rebuilt and now National Railway Museum)
- Hydraulic Power House
- Red brick building off Leeman Road
- Learning Platform

Also included for possible retention are

- Generator Building
- Fire House
- Alliance House
- Carriage Works Mess Room

The group value of the Former Goods Station, Weigh Office, Gate Piers, Bullnose Building and horse stables together is of high significance.

The York North Engine Shed and Hydraulic Power House are adjacent to this collection of buildings but have medium significance as a group.

The Albion Foundry buildings have medium significance as a group.

The significance of each individual heritage asset is noted in the later sections in this chapter, alongside a brief note of the asset's former function and history, where known. Significance levels assigned are based on an assessment set out in the Heritage Statement submitted with this application.

Significance is assigned as high, medium or low. It should be noted that 'low' significance denotes 'some' significance, rather than 'no' significance. The assets have all been considered worthy of retention, offering opportunities for re-use which will contribute to the regeneration of York Central.

**The development of York Central is to be cognisant of the heritage assets on the site and of their significance.**

**Retained heritage assets are to be treated in accordance with good conservation practice.**

### 5.1.3 Archaeology

A Roman burial ground has also been identified on site beneath the present station and immediately to the north of it. Further Roman burials are known on Holgate Road, Blossom Street and throughout the vicinity. Geological sink holes and buried wetland along the path of Holgate Beck allude to evidence of prehistoric activity. Refer to the Archaeology and Built Heritage report for further discussion.

**The development of York Central shall be cognisant of the potential for significant archaeological assets on the site.**



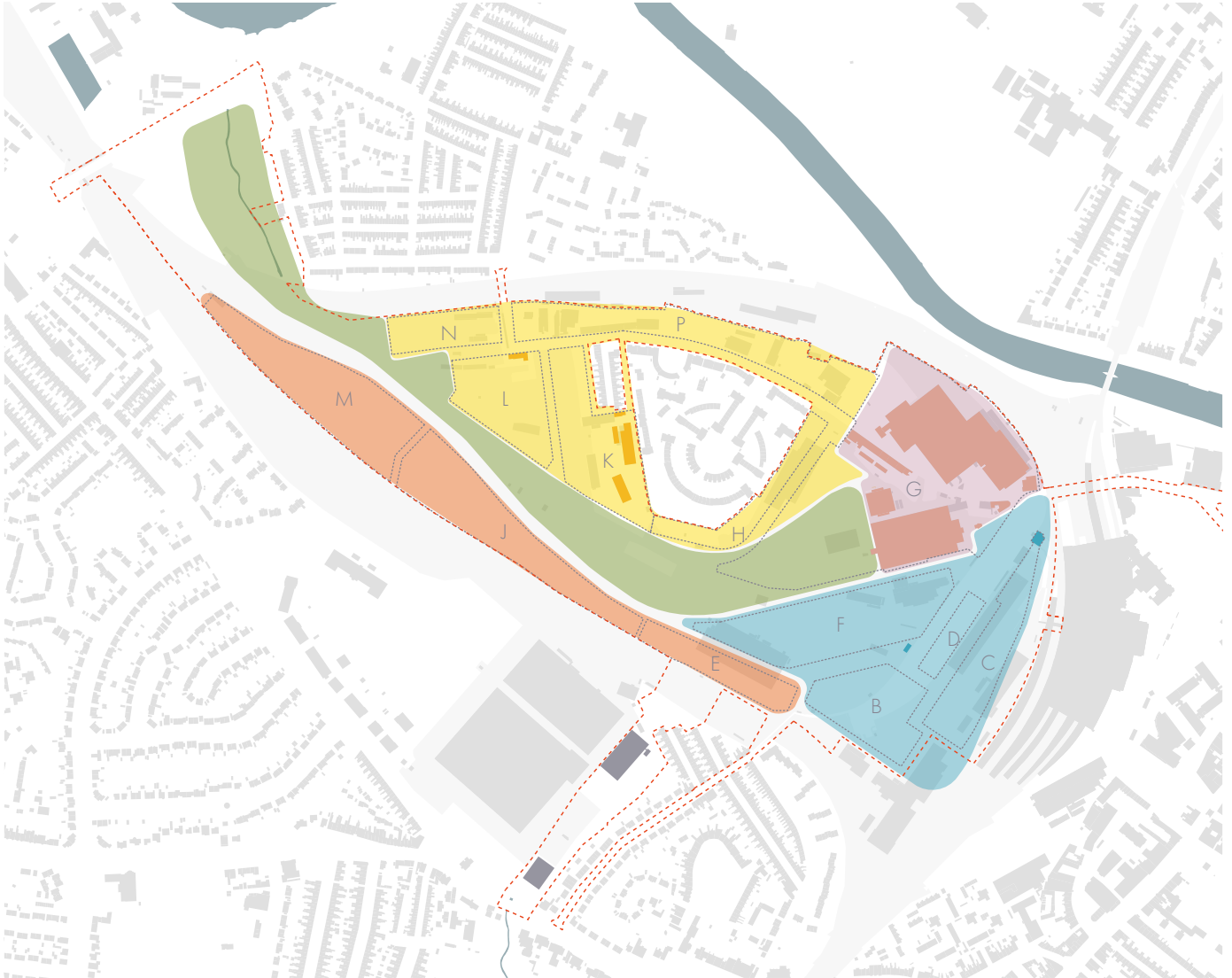

Fig.234 Plan of heritage assets in each Character Area of York Central. For each heritage asset, refer to the Character Area

- Central Park (for treatment of heritage assets, including railway objects, refer to page 58)
- National Railway Museum, refer to page 152
- Station Quarter, refer to page 160
- York Yard South (no built heritage assets retained in this Character Area)
- Foundry Quarter, refer to page 154
- Chancery Rise, refer to page 163

## 5.2 GENERAL GUIDANCE

The following guidance applies broadly to all heritage assets on York Central site - both designated and non-designated. Where the heritage asset is Listed works may require Listed Building Consent in addition to a RMA. Notwithstanding the following guidance, the developer of each heritage asset is responsible for obtaining the appropriate consents for the proposed works.

### 5.2.1 New Extensions

New insertions or interventions shall continue the industrial aesthetic in a sympathetic, contemporary manner.

When adjoining heritage buildings - designated and non-designated - extensions shall respect the form and detailing of the historic buildings.

**New structures shall not obscure original window and door openings; arches and surrounds; piers, plinths panels and bays; or ornamental features such as cornices and string courses should be retained.**



Fig.235 Example of contemporary extension to an industrial heritage asset (Albert Works, Sheffield)



Fig.236 Example of contemporary interventions in brickwork (Seta Bonet architects)



Fig.237 New windows and entrance at the Eberhard Faber Pencil Factory, Brooklyn

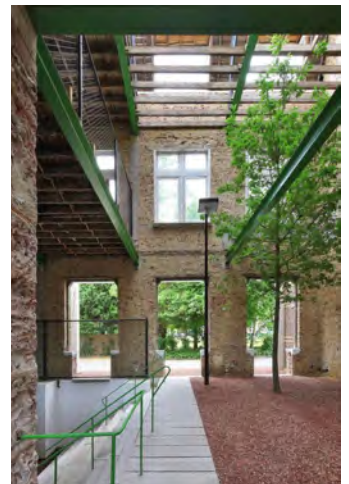

Fig.238 Industrial space re-used, Melle, Belgium, part open space, part care home

5.2.2 Roofs

Roofs to heritage assets shall retain their basic form with alterations kept to the minimum.

Every effort shall be made to minimise the raising of roof levels and to avoid the consequent thickening of the eaves and verge details.

There shall be no visible UPVC rainwater goods.

Replacement of stone slate or tile roof coverings shall match the original slate or tile roof covering.

When replacing existing non-original concrete tiles, felt or corrugated metal pitched roofs, reinstatement of the original slate or tile material is strongly encouraged. If considered appropriate, metal sheet material may be used as an alternative. The colour of metal roofs shall match the grey-blue colour of lead or slates.

Artificial slates, synthetic clay tiles, tile effect metal sheet will not be acceptable.

Rooflights in former railway sheds should be arranged in a linear fashion, not dotted around.

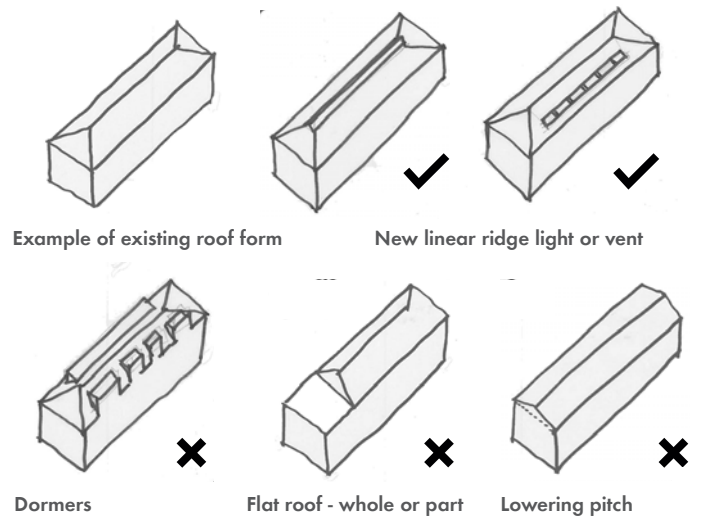

Fig.239 Form of roofs to heritage assets

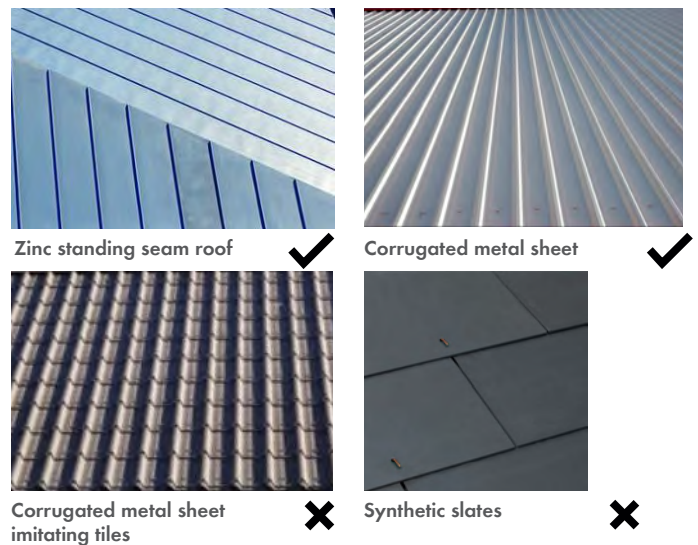

Fig.240 Acceptable and non acceptable materials

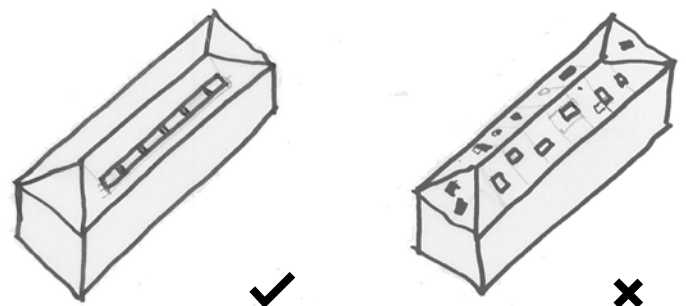

Fig.241 Rooflights to railway sheds

### 5.2.3 Walls

Exposed brickwork including characteristic brick details shall remain exposed. External brickwork shall not be concealed behind, for instance, external insulation or over-cladding.

Over-cleaning of masonry is to be avoided.

Masonry walls shall be repaired using appropriate techniques according to good conservation practice.

This is likely to include repointing in lime-based mortar. Wherever practicable, cement pointing should be replaced with lime-based mortar pointing, subject to trials and assessment.



Fig.242 Existing railway shed in the Albion Foundry area



Fig.243 Inappropriate cement pointing



Fig.244 Cement pointing ideally should be replaced with lime-based mortar pointing



Fig.245 Exterior insulation covering brick details on historic building in Germany



### 5.2.4 Windows and doors

**Fenestration shall continue the industrial aesthetic in pattern and in material.**

The re-use, repair and upgrade of original historic windows will always be the preferred solution.

New or replacement timber and metal windows may be an acceptable alternative.

**There shall be no UPVC windows or doors.**



Fig.246 Existing iron window could be retained and repaired



Fig.247 Examples of good metal contemporary windows and doors



Fig.248 PVC window



## 5.3 NATIONAL RAILWAY MUSEUM

The National Railway Museum is the main cultural focus of York Central and will play a central role in the regeneration of the site. The museum contains a large proportion of the York Central's heritage buildings. This section outlines the role the museum will play in York Central, lists its heritage assets and briefly describes the potential developments under consideration by the museum.

### 5.3.1 Role of the National Rail Museum

The National Railway Museum is the main cultural focus of the York Central site and will play a central role in the regeneration of the site. Already a great draw for visitors to York, the museum aims to increase its visitor numbers, and to “radically improve the breadth and depth of public experience and engagement”

The Museum's interest and guardianship extends to the public space around the museum, including the 'Museum Gateway' (the western half of New Square) and the connection through to Leeman Road West. The development of the museum will frame the western half of New Square and support activities which take place in the square. The museum buildings, both new and old, will have a civic role to play in the New Square.

### 5.3.2 Museum buildings

The National Railway Museum area of the Masterplan contains a large proportion of the York Central's heritage buildings. The existing buildings are the Former Goods Station and the North York Engine Shed, Bullnose building, Weigh Office, the Hydraulic Power House (operational Network Rail building), the Learning Platform, and the Former North Eastern Railway horse stable. Together these form a cohesive group.

In line with its own Conservation Management Plan and this Design Guide the Museum will evolve Masterplan proposals that improve the setting and understanding of heritage assets and accord with good conservation practice.

### 5.3.3 Development of the Museum

The heritage buildings are under the stewardship of the National Railway Museum who will develop proposals for their sympathetic conservation and continued long term use.

New buildings in this area will be the new gallery and extensions to the museum. Mews buildings may be introduced in association with the horse stables. New buildings will complement and enhance the existing heritage assets, and create a significant new public building for the city of York.

The process of design and development of these new buildings will be taken forward by the National Railway Museum. The development will be a significant and integral part of the Masterplan. No specific guidance is provided in this chapter, but reference is made in Chapter 2 to the parameters for height and massing and the boundary of the museum area.

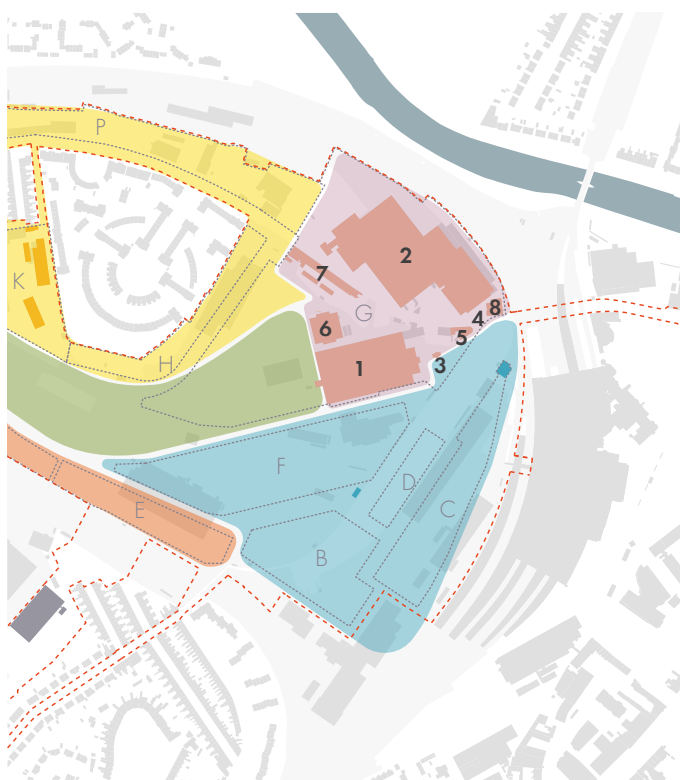
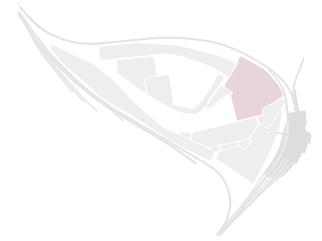

Fig.249 National Railway Museum heritage assets

- 1 Former Goods Station
- 2 York North Engine Shed
- 3 Weigh Office
- 4 Gate Piers
- 5 Bullnose Building (former Coal Manager's Office)
- 6 Learning Platform
- 7 Stables
- 8 Hydraulic Power House (operational Network Rail building)



1 Former Goods Station (Grade II listed)



5 Bullnose Building (former Coal Manager's Office) (non-designated)



2 York North Engine Shed (non-designated)



6 Learning Platform (not separately listed)



3 Weigh Office (Grade II listed)



7 Stables (non-designated)



4 Gate Piers (Grade II listed)



8 Hydraulic Power House (non-designated)

Fig.250 Photographs of heritage assets in the National Railway Museum area

## 5.4 FOUNDRY QUARTER

This section lists the heritage assets in the Foundry Quarter and their designations, briefly describing their historical function and their significance. Guidance is offered regarding potential changes to the external appearance of the buildings, and where new extensions may be considered.

### 5.4.1 Introduction

The Foundry Quarter contains a number of retained non-designated heritage assets, including buildings of the former Albion Iron Foundry, and a small building on Leeman Road. These heritage assets will be fully integrated into York Central's new development. Indeed, they will be 'anchors' for the making of public and community places in the primarily residential development around them.

For guidance on the locations of new buildings and additions forming the new Foundry Yard around the old Albion Foundry buildings, refer to Chapter 2. For the landscaping and character of this new public place refer to Chapter 3. For outline general guidance on treatment of the retained heritage assets, refer to section 5.2 in this chapter.



Fig.251 Foundry Quarter heritage assets



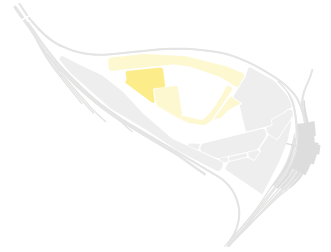

1 Foundry Yard



3 Albion Iron Foundry Warehouse ('Engine Shed')



1 Foundry Yard



4 Smith's Shop Office



2 Albion Iron Foundry Shop



5 1930s Leeman Road building

## 5.4.2 Albion Iron Foundry Shop

Unlisted - Medium Significance

Designed by architect Charles Toft and built in the 1870s.

**Both the shop and parallel brick shed shall be retained and adapted for new uses.**

**The shop itself shall not be extended. External elevations shall remain free of any new building.**

Subsidiary structures such as porches or canopies may be placed over openings on the short sides of the building.

### Main Shop

Individual rooflights are discouraged in the long clay tile roof. If rooflights are required, a long central glazed rooflight or clerestory may be considered instead.

**New window and door openings are to be kept to a minimum.**

Any new opening must be carefully designed but may be differentiated from the original arched openings to read as a clearly modern insertion.

### Parallel brick shed

New rooflights in the slate-covered roof may be considered.

Any new window and door openings should respond to the bay pattern of the existing brickwork.



Fig.252 Albion Iron Foundry shop - main building - east facade



Fig.253 Albion Iron Foundry shop - main building - west facade



Fig.254 Albion Iron Foundry shop - parallel brick shed - west facade



Fig.255 Albion Iron Foundry shop - parallel brick shed

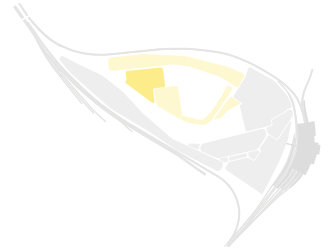

### 5.4.3 Albion Iron Foundry Warehouse ('Engine Shed')

Unlisted - Medium Significance

**The warehouse shall be retained and adapted for new uses.**

Development may adjoin part or all of the west elevation.

**A minimum of three full elevations shall remain free of extensions.**

Subsidiary structures such as canopies or porches may be placed over door openings on the short sides of the building.

New rooflights in the slate-covered roof may be considered.

New window or door openings in brick walls should be differentiated from the original arched openings to read as a clearly modern insertion.



Fig.256 'Engine Shed' north facade



Fig.257 'Engine Shed' north facade east facade

#### 5.4.4 Smith's Shop Office

Unlisted - Medium Significance

**The building is to be retained and repaired.**

It may be altered and extended to accommodate new uses.

**There shall be no extensions to south or east sides, although a porch or canopy may be considered.**

An extension may be considered to the west side, but should be subservient to the original office building.

**Chimneys shall be retained** (even if rebuilt)

Soil pipes and redundant services shall be removed from the front and east elevation.

**New dormers shall be avoided on the south slope.**

Dormers may be considered for the hips and north slope.

**Any new window openings shall match existing details.**

**Timber sash windows with suitable fenestration pattern consistent with the original date of the building are to be installed.**



Fig.258 South frontage of Smith's Shop Office



Fig.259 East frontage of Smith's Shop Office

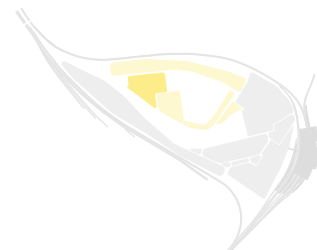

#### 5.4.5 1930s Leeman Road building

Unlisted - Low Significance

**The building is to be retained and repaired.**

The building may be altered and extended to accommodate new uses.

**Fenestration pattern in existing windows is to be retained.**

The building may be extended to first floor level.

**Any extension at first floor level shall occupy no more than 60% of the roof footprint, and be set back from the ground floor elevations.**

**Any extension at upper floor level shall be in a material to contrast with brick base, such as glass or metal.**



Fig.260 1930s building seen from Leeman Road



Fig.261 South elevation of 1930s Leeman Road building



Fig.262 Example of a roof extension in material contrasting with the brick base

## 5.5 STATION QUARTER

This section lists the heritage assets in Station Quarter and their designations, briefly noting their historical function and their significance. Guidance is offered regarding potential changes to the external appearance of the buildings, where new extensions may be considered, or if the building may even be relocated.

### 5.5.1 Introduction

The Station Quarter will retain one large and two small heritage assets. The Coal Drops, currently used as a carpark, forms a substantial brick basin in the east of the site. The smaller assets are the former Generator Building which sits on the brick railway viaduct at the north end of Station Quarter, and the former Fire House located more towards the centre of Station Quarter or other suitable location.

The Generator Building forms an attractive, solid 'stop-end' to the new development on the east side of New Square. The Fire House, a timber structure, has the potential to be dismantled and re-erected in another location in York Central. Both could be adapted for new uses.

For the intended character of the public open spaces in which these heritage assets sit, refer to Chapter 3. For outline general guidance on treatment of the retained heritage assets, refer to section 5.2 in this chapter.

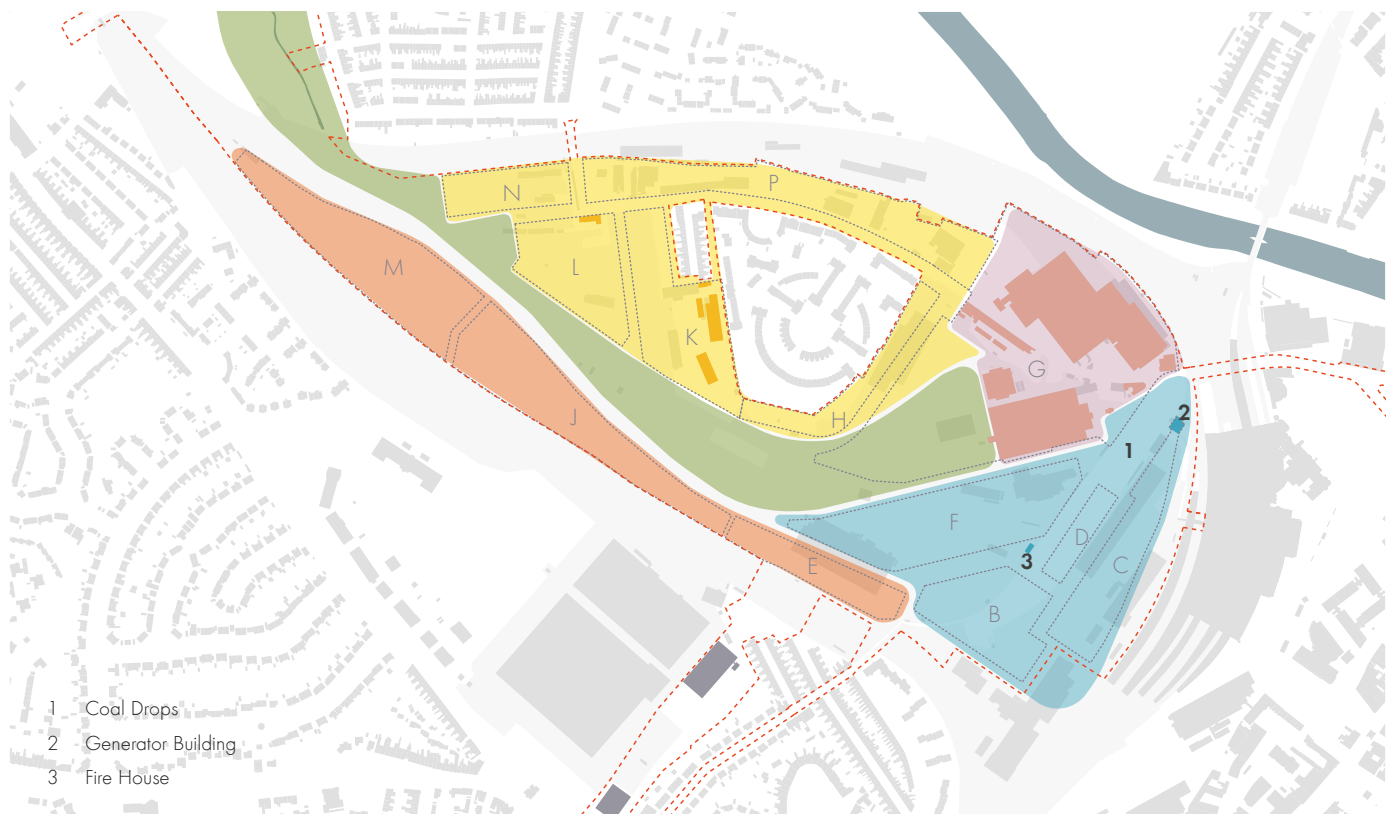

Fig.263 Station Quarter heritage assets



### 5.5.2 Coal Drops

Unlisted - medium significance

The Coal Drops have been considerably altered over time but still have aesthetic value in their buttressed walls and dramatic changes in level. Proposals incorporate the Coal Drops into the landscape scheme for New Square.

**The Coal Drops shall be retained, along with partial conservation and re-use, along with substantial landscape improvements and interpretation.** Refer to Chapter 03 public Open Space for landscape proposals.

More of the parapet wall may be exposed on the wall side following the adjustments to landscape levels in New Square. **Contrasting brick should be used for areas for repair or infill so that the original railway level may be discerned.**



Fig.264 Coal Drops seen from the south



Fig.265 East face of the Coal Drops with the National Railway Museum beyond

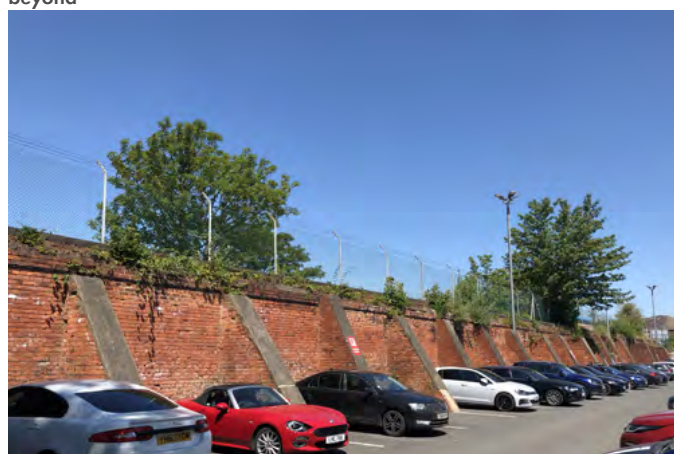

Fig.266 Coal drops with the original coal cells trimmed back to form buttresses



### 5.5.3 Generator Building

Unlisted - low/medium significance

**The building may be retained or demolished.**

It may be altered and extended to accommodate new uses.

New windows may be formed in other faces of the building, overlooking the new square and towards Marble Arch.

The building sits on the viaduct, and there will be a level change between the square and the 'ground floor' of the Generator Building. Step-free entry into the Generator Building may be achieved through an adjoining new building, or through new ramp, steps or lift integrated into the landscape design of the square.

**Windows on the elevations facing away from the square shall retain the existing fenestration pattern, even if replaced with new.**

The building may be extended at first floor level, but avoiding obscuring views of gables of York Station.

**Any extension at upper floor level shall be in a material to contrast with brick base, such as glass or metal.**

### 5.5.4 Fire House

Not designated - low/medium significance

This small timber shed off Cinder Lane appears on maps of 1930s but may be older. Known to Network Rail as the Fire House it is currently assumed to have stored a fire engine.

It is recommended the shed should be carefully recorded and dismantled for re-erection elsewhere in York Central.

Suggested locations might include the Foundry Yard or Central Park.

Historic maps indicate rail tracks running into the building: the new location should position the shed parallel to tracks or a similar sweeping element in the landscape, so it reads in a similar way.



Fig.268 Generator building seen from the west



Fig.269 Generator building seen from the east



Fig.267 The Fire House viewed from the west



## 5.6 CHANCERY RISE

The heritage assets face onto Chancery Rise, which is lined on its opposite side by the wall to back gardens of local houses. Both Alliance House and the Carriage Works Mess Room have high communal and historical significance as part of a group of buildings representing a major part of York's railway history.

### 5.6.1 Carriage Works Stores and Office

Unlisted - High significance

The building is also known as Alliance House.

**The building may be retained or demolished.**

The building's retention and re-purposing is encouraged. The building may be altered and extended to accommodate new uses.

Effort should be made to retain original windows where these exist.



Fig.270 Carriage works stores and office, also known as Alliance House

### 5.6.2 Carriage Works Mess Room

Unlisted - Medium significance

**The building may be retained or demolished.**

The building's retention and re-purposing is encouraged. The building may be altered and extended to accommodate new uses..



Fig.271 Carriage works mess room



## 6 APPEARANCE SITE WIDE

This section outlines how the different spaces and buildings across the site should be articulated. It sets out common guidelines for the composition of different building elements, materiality, proportion and palettes of materials. The chapter contains guidance for the qualitative aspects of the appearance of public spaces and buildings.

## 6.1 INTRODUCTION

**This chapter covers aspects of the appearance of York Central's new buildings which are common to all the Character Areas. Chapter 07 contains guidelines that are specific to each Character Area. The guidelines steer the appearance of the "background" buildings which together will form the most of York Central's urban fabric, but also point out opportunities for "foreground" buildings.**

---

Of the masterplan principles, three in particular guide the appearance of York Central as part of the city:

"The unique character and history of the site shall inform the design response."

The railway heritage of the site is an essential ingredient of this new part of York.

The railway heritage will be in the DNA of the new places in York Central and the buildings which form them.

York Central's new buildings will draw on the industrial heritage of the site – evolving the typology of robust brick structures which once housed railway activities to become contemporary buildings for housing, workspaces, shops, hotels and community spaces. The language of robust brick industrial buildings will be developed and elaborated to accommodate and reflect these new uses.

Design shall "respect and enhance the heritage buildings and the historic city, considering urban grain and proportions in relation to both the local and wider context".

The buildings in York Central shall also look beyond the immediate railway heritage to the wider city context, to the walled city and the surrounding city villages.

York contains a great variety of architectural styles and materials, but throughout its different localities the city possesses particular characteristics which together create an essential "Yorkness". This "Yorkness" includes a special "human scale" – an intimacy of scale and quality variously described as "diversity, contrasts and surprises", "quirkiness", and even "higgledy-piggledy-ness" within a regular urban grain.

The urban grain varies from the grain of the walled city to the looser grain of the city villages. This grain provides the regular framework within which buildings vary in form and pattern, with a rich diversity of detail, a mix of formality and informality.

In appearance, the resulting mix of form and pattern within a rhythm has been defined as a kind of "uniform irregularity" discussed in more detail in 6.2 below.

A very few buildings in special locations shall stand out from the urban fabric of York Central. These shall be considered *foreground* buildings, and are discussed in 6.4 below.

"York Central shall seem an extension of the existing city fabric, and not a distinct new place"

The overall form of the new urban quarter in York Central shall nestle naturally into the city.

From afar, York Central should have the same texture and tone as the existing city – roofs and walls matching the existing in appearance and rhythm.

In density, York Central will match the historic city, but in the generosity and frequency of green spaces it will resemble more the nearby York city villages. The character of the York Central buildings and spaces will combine both in a 21st century model of the Garden City. It will follow in the steps of New Earswick: in its integration of landscape and building affording "charming peeps of the countryside or secluded gardens from the street", homes with a "cheerful outlook" (Parker and Unwin 1901) and the buildings "well built, convenient, healthy and artistic in design" (New Earswick Brochure 1913).

Images right: Photographs of York buildings showing they vary in character from the "higgledy-piggledy-ness of the medieval streets, through the robust brick structures of York's industrial history, to the bucolic charms of New Earswick and the York suburbs. These qualities shall be brought through into York Central's Character Areas.



Fig.272 Robust brick structures of York Central Fig.273 Robust brick warehouse buildings on the Ouse river bank



Fig.274 Chapter House street, York

Fig.275 Glimpses of York Minster across the rooftops

Fig.276 higgledy-piggledy streets



Fig.277 Quirkiness and human scale in the medieval streets of York

Fig.278 "Charming peeps of secluded gardens" in New Earswick (quotation by Parker & Unwin)

## 6.2 “UNIFORM IRREGULARITY”

“Uniform irregularity” is used here to describe the mix of form and pattern which characterises the buildings forming York’s streets. The term aims to communicate the diversity yet consistency of the city’s built fabric. Facades of these buildings offer variations on a theme, forming a cohesive environment - one which forms the “background” to York streets and that delights with its regular-irregular rhythm.

### 6.2.1 “Uniform irregularity” and Character Areas

Buildings throughout York Central will together exhibit this “uniform irregularity”. Some key buildings - called “foreground buildings” - will stand out from and punctuate this rhythm of “uniform irregularity”. These are described in 6.4 below.

The degree of “uniform irregularity” will vary according to Character Areas shown in the plan below.

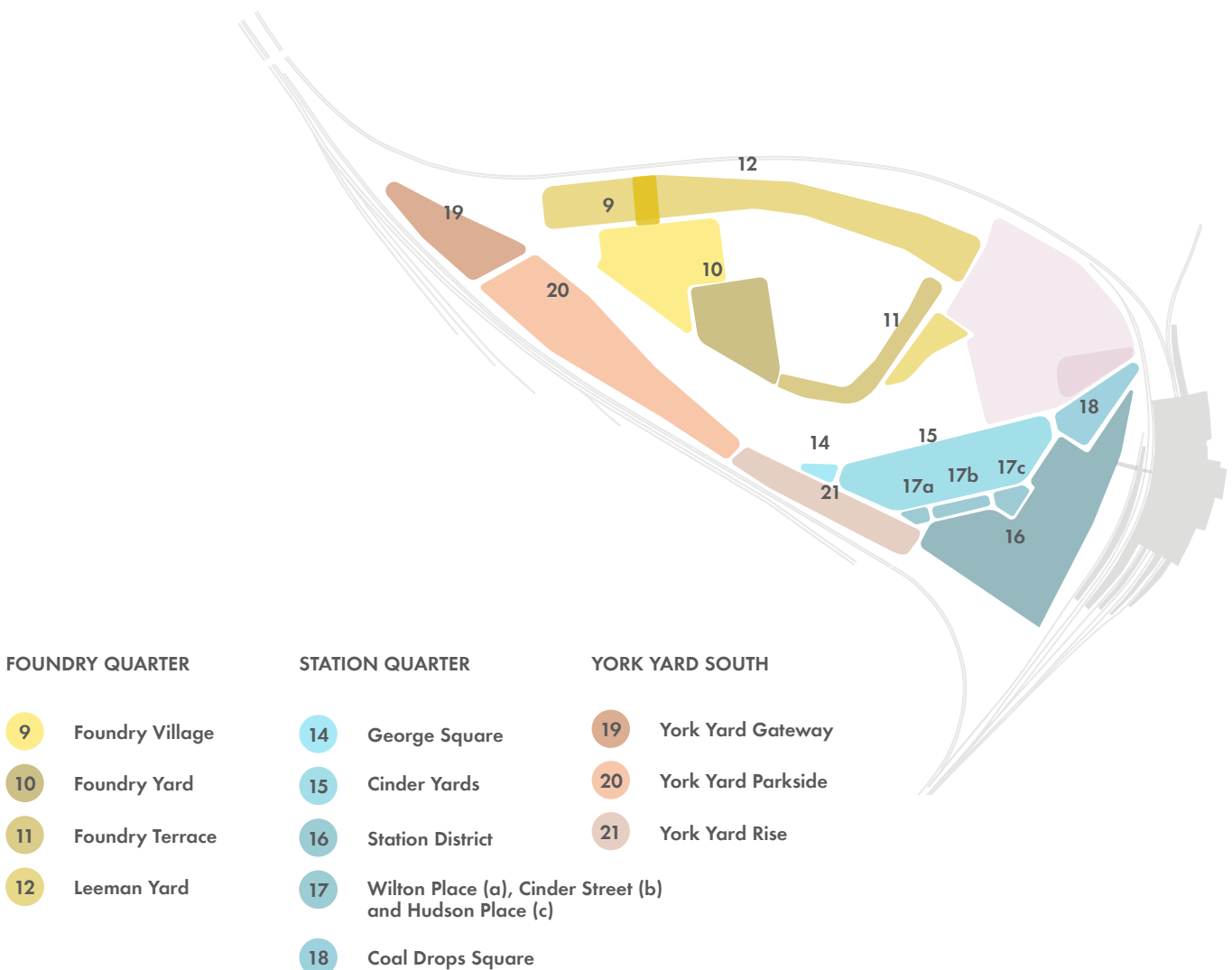

Fig.279 Character Areas which exhibit varying degrees of “uniform irregularity”

### 6.2.2 Sliding scale of “uniform irregularity”

The degree of “uniform irregularity” in the building composition shall vary across the site, from more uniform in the Station Quarter, through the predominantly regular but quirky terraces of the Foundry Village, to the highly modelled and varied mansion blocks of Leeman Yard and York Yard South. The sliding scale of “uniform irregularity” is illustrated below.

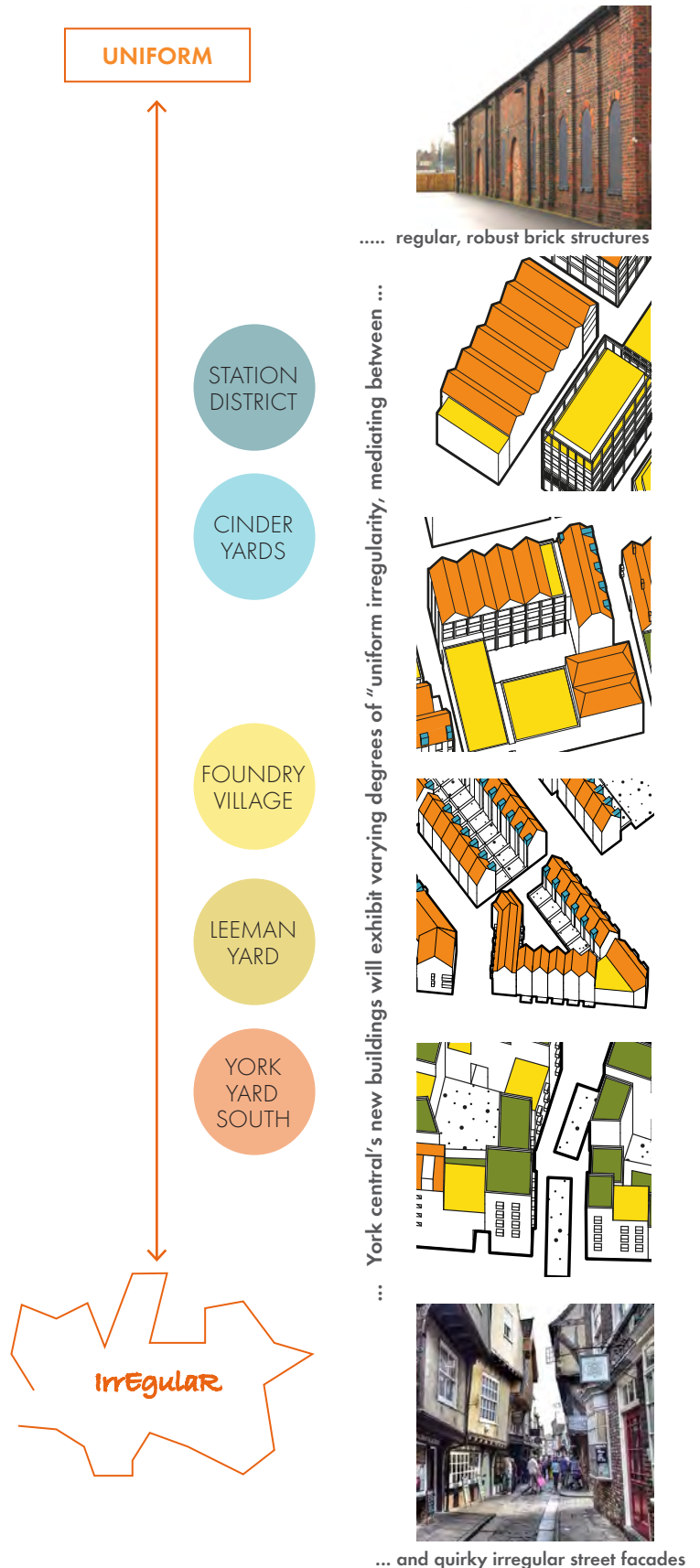

Fig.280 Sliding scale of “uniform irregularity” for the development zones in York Central

## 6.3 GRAIN

The development of York Central shall bring in the urban grain from the surrounding city to inhabit and intensify the site's existing grain left by now departed railway industry. The development shall transition from the tight grain of the walled city east of the site to the looser grain of the city villages to the west of the site.

### 6.3.1 Urban grain

Prior to the arrival of the railway, the site of York Central was agricultural and it had no urban grain of its own. As a former railway yard it currently has a grain of railway tracks and large footprint buildings. This grain is authentic to the site but, being a function of transport and industry, it does not translate directly into places for living and working in the city. To accommodate these new uses in its buildings and urban places, the York Central development shall bring in and adapt the grain from the surrounding city.

Some of the new building types in York Central are unprecedented in York: commercial buildings with large floor plates are essential for a certain scale of modern business; apartment blocks are needed with the potential to contain a high density of smaller scale flats. The familiar urban grain of the medieval city and York's urban villages will be adapted for these new building types. This new, adapted urban grain will incorporate the human scale, snickets and permeability of the historic city.

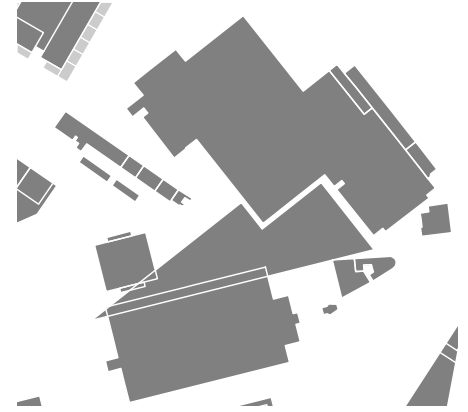

Fig.281 Grain diagram, National Railway Museum

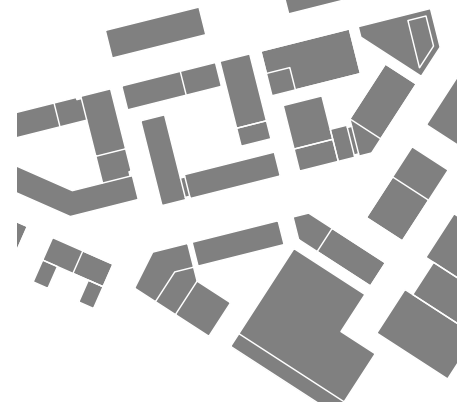

Fig.282 illustrative grain diagram, Station Quarter



Fig.283 illustrative grain diagram York Yard South

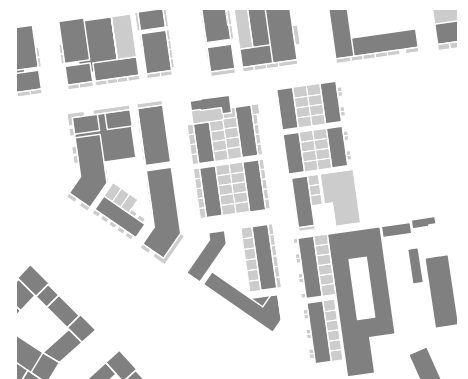

Fig.284 Illustrative grain diagram, Foundry Quarter



## 6.4 BACKGROUND AND FOREGROUND BUILDINGS

Most of the buildings which will form this matrix of “uniform irregularity” will be *background* buildings. A very few buildings, in key locations in York Central, will be *foreground* buildings which will stand out from the background buildings in their appearance. These buildings will exploit views within York Central, provide a focus in public spaces, and bring in the York qualities of surprise and contrast.

### 6.4.1 Background buildings

Almost all of the buildings which will form York’s matrix of “uniform irregularity” are *background* buildings. These buildings may well have their quirks and be quite diverse, but they do not shout or jostle for attention. Instead, together with their neighbours, these buildings form a cohesive urban environment, rich with contrasts and surprises, but run through with a certain consistency. The visual pleasure and interest in this environment comes from the assemblage of buildings with a common theme - a rhythm arising out of variations on this theme.

### 6.4.2 Foreground buildings

Into this background matrix will be set a few select, *foreground* buildings. These buildings may depart from the rules for “appearance” which the *background* buildings must generally obey. *Foreground* buildings may use different facade materials from the predominant brick, different forms to the primarily rectilinear forms of the background buildings, their facade emphasis may be horizontal rather than vertical, the colour palette may vary. These buildings however must still obey the massing and townscape rules which apply to York Central, and be sympathetic to surroundings and contextual in their design.

Refer to Chapter 07 for foreground buildings in each Character Areas.



Fig.285 Locations for “foreground” buildings

## 6.5 ROOFS SITE WIDE

This describes the site wide approach to the design of the roofscape of York Central. It includes a description of the range of materials which may be used across the whole of the site, and the typical details which will apply across all Character Areas. Aspects of roof design special to each Character Area are then covered in the individual Character Area sections.

### 6.5.1 Roofscape

York's roofscape is a characteristic part of the city, seen from high vantage points within and around the city. The roofscape of York Central is a critical part of the new development and how it will nestle into the historic city as "an extension of the existing city fabric, and not a distinct new place"

Roof forms should be designed so that they settle within the city fabric such that the landmark buildings such as York Minster, the Principal Hotel, the St Wilfred's church and the Grand Hotel remain dominant features on the city skyline.

The texture of the York Central roofscape shall be similar to that of the surrounding historic city. The

roofscape shall be formed predominantly of pitched roofs, in combination with flat roof terraces. All roofs and terraces shall be fairly small scale and there shall be a variety of levels and orientation. The grain and direction of roofs shall respect the street pattern, being either parallel or perpendicular to it. Pitched roofs may vary in material and slope. The roofscape for each plot within a Development Zone shall contribute to this overall texture.

Large expanses of flat or pitched roofs which catch the eye and appear alien in short and long distance views will not be acceptable. The scale of large roofs and rooflines on larger building blocks shall be broken down to achieve visually a similar scale to the roofs in the surrounding inhabited city – a "human scale" rather than an industrial scale.



Fig.286 View of York Minster within the existing roofscape of York



Fig.287 Grain and variety of York's roofline



Fig.288 Very large scale, repetitive industrial roofs ❌



Fig.291 Small scale roofs to houses on St Andrewgate ✔️



Fig.289 Large scale clay tiled roof to Coppergate shopping Centre ❌



Fig.292 Small scale roofs to houses on George Street ✔️



Fig.290 Large flat roof to Post Office ❌



Fig.293 Large riverside buildings along the Foss ✔️

### 6.5.2 Roofline and Skyline

**A “uniform irregularity” of the roofline and skyline shall be achieved overall at York Central.**

The roofline and skyline of each Development Zone shall contribute to this “uniform irregularity”. Variation to the roofline shall result from any combination of the following: parapets (including stepped parapets), gables and dormers.

The skyline may be varied and broken down in scale using different heights of roof, and/or party wall parapets, and/or ventilation chimneys where appropriate.

Chimneys shall be of high quality, contemporary in detail, and generally of brick to match the facade walling.



Fig.294 Existing York roofscape variety



Fig.295 Existing York roofscape variety



Fig.296 An example of good contemporary chimney design in Accordia, Cambridge

### 6.5.3 Roof materials

Pitched roofs on York Central buildings shall be covered in plain clay tiles, or curved clay pantiles, or natural slates to BS EN 12326-1. These roof coverings may be used anywhere on the York Central site.

Roof pitches shall typically be between 35° and 45° (to facilitate the use of clay plain tiles and pantiles) and 25° to 30° to facilitate slate. Roof pitches and detailing shall relate to the material used.

Occasional pitched roofs and commercial roofs may be covered in metal (such as lead or zinc). Metal clad pitched roofs may also be appropriate if complimentary to the building design and in natural colours such as zinc, copper or lead.

Flat roofs shall either be occupied terraces or be planted – either with ‘green’ or ‘brown’ roofs.

Brown roofs shall be on high level roofs only, and shall always have parapets.



Fig.297 Plain clay tiles



Fig.298 Curved clay pantiles



Fig.299 Lake District slates



Fig.300 Welsh slates



Fig.301 Green roof



Fig.302 Brown roof

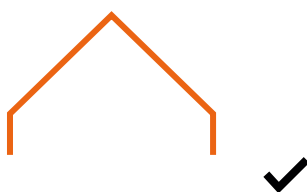

Fig.303 35° - 45° clay tiles roof



Fig.304 Predominantly pitched roof



Fig.305 Predominantly flat roof



Fig.306 25° - 30° slate roof



Fig.307 Predominantly pitched roof



Fig.308 Too shallow pitch

## 6.6 ROOF EDGES

The quality of roof edges will be critical in defining the quality of the streets in York Central. Existing traditional buildings in York exhibit a variety of eaves, verges and parapets, which all contribute to the attractive and highly modelled roofline of the city streets. New buildings shall take their cue from these details.

### 6.6.1 Eaves

Modelled, projecting eaves cornices are a feature of many of the more substantial, traditional York buildings.

Treatment of the eaves of substantial buildings within York Central shall take their cue from these York traditional details, interpreting them in a contemporary way.

**Refer to Character Areas for recommended treatment of eaves details.**



Fig.309 Examples of the many different existing eaves details in York



Fig.310 Example of a contemporary eaves detail

### 6.6.2 Gutters and downpipes

Refer to Character Areas for where gutters and downpipes may be exposed, and where they are required to be hidden.

**Any visible gutters and downpipes shall be metal (UPVC will not be acceptable).**

**Exposed gutters and downpipes shall be integrated with the facade design.**



Fig.311 Recessed downpipes



Fig.312 Hidden downpipes



Fig.313 Exposed downpipes integrated into facade design



Fig.314 Ill-considered downpipes

### 6.6.3 Gables and verges

Pitched roof gables to street frontages within the walled city usually have masonry parapets or a projecting verge detail including a decorative barge-board and/or bracket. Simple tiled verges may also be found.

The gabled parapets of the existing 19th century railway buildings around York Central frequently feature a brickwork corbel to the top edge. In some cases, gables are topped by a projecting verge with barge-board and bracket.

The pitched roof gables and verges of new buildings within York Central are to take their cue from these existing details.

The design of gables and verges may vary depending on Character Area. Refer to the Character Area sections in Chapter 07.

**There shall be no box verges on any building**



Fig.315 Examples of existing modelled gables in York



Fig.316 Contemporary modelled verges



Fig.317 Contemporary projecting verge



Fig.318 Plain tiled verge

#### 6.6.4 Parapets

York rooflines “acknowledge the human scale with modelling or decorative parapets”. Parapets have a variety of detail ranging from plain solid walling with a small projecting coping, through those with string courses and balustrades, to much more elaborate pierced parapets to special or landmark buildings.

**The new buildings within York Central shall employ a range of contemporary masonry parapet details to enrich the skyline seen both from within York Central and beyond.**

**Buildings whose tops are seen from the city walls, rising above the train shed roof of York station, shall have a distinctive parapet incorporating openwork through which sky can be seen.**

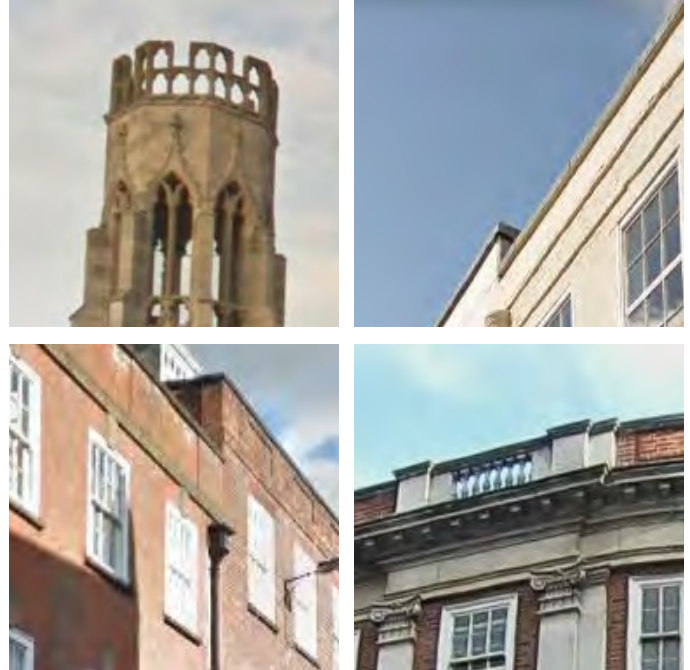

Fig.319 Examples of historic modelled parapets in York

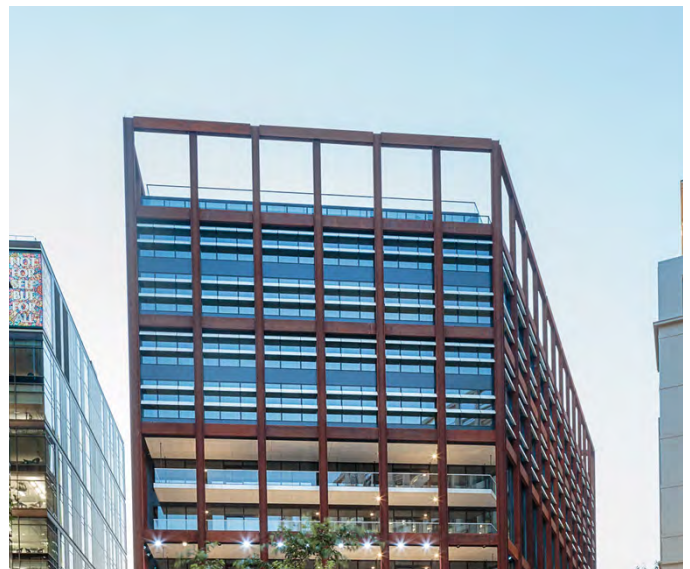

Fig.320 Example of modern openwork parapet





### 6.6.5 Chimneys

The variation of the roofline using 'chimneys' for light ventilation is strongly encouraged. Chimneys shall be contemporary in detail.



Fig.321 Examples of contemporary chimneys



## 6.7 DORMER WINDOWS

This describes the site wide approach to the design of the dormer windows in York Central. It includes a description of the range of materials which may be used across the whole of the site, and the typical details which will apply across all Character Areas.

### 6.7.1 Dormers

York's historic dormers include Georgian dormers set back from the roof edge and less seen from the street, and Victorian dormers brought forward to become part of the picturesque roofline and street frontage. Dormers in York Central may follow either pattern (set back or brought forward), but reinterpreted in a contemporary manner.

**Dormers shall be designed as an integral part of the street facade. Dormers shall be subsidiary to the main roof (not dominate in scale). Dormers shall respect elevation bay divisions. Gutters and downpipes to dormers must be discreet and integrated into the dormer design.** Dormers cheeks may be tiled in the same roofing material as the main roof, or may be clad in a contrasting material such as timber or metal. **Dormers shall be well-articulated in design and have crisp contemporary detailing. The window shall occupy the full front width of the dormer** (and not be a small opening in an over-sized dormer). In addition 'inverted dormers' may be used to form roof terraces in pitched roofs.

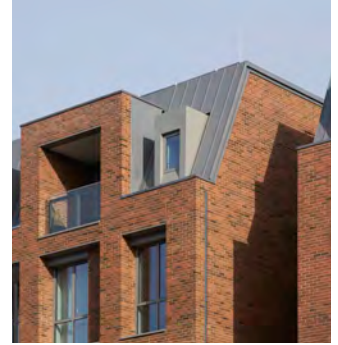

Fig.326 Examples of contemporary dormer windows



Fig.327 Examples of contemporary dormer windows at Derwenthorpe, York



Fig.328 Example of inverted dormer

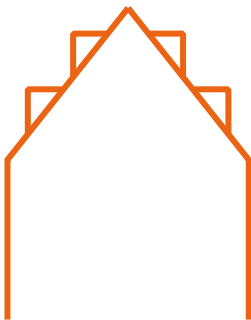

Fig.322 Double dormer

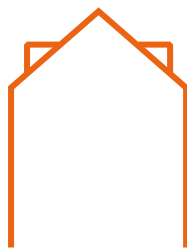

Fig.323 Set back dormer



Fig.324 On line of facade

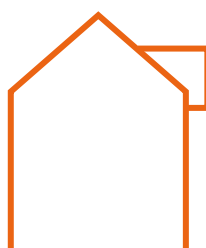

Fig.325 Dominating dormer



Fig.329 Not integrated with facade, dormer too big (dominates the roofline and elevation), windows too small, no articulation of dormer elevation, roof slope shows cheap roofing material, exposed gutter delivering to roof



## 6.8 SOLAR PANELS

The use of solar panels is encouraged, subject to their full integration into the design of roofs in York Central.

For slate roofs, solar photo-voltaic cells may be used which match the appearance of the natural slates used in the roof covering.

Solar panels in clay tile roofs must be carefully detailed to be integrated into the design of the roof and to sit flush with tile roof surface.

Solar roof panels should not dominate the appearance of the roofs.

**The use of solar panels should be avoided on the roofs of heritage buildings.**



Fig.330 Examples of PV cells with slate or tile appearance. ✓



Fig.331 Example of solar roof panels integrated into the roofscape, flush with the roof covering ✓

## 6.9 WALL MATERIALS SITE WIDE

This describes the site wide approach to the design of the external walling of York Central. It includes a description of the range of materials which may be used across the whole of the site, and the typical details which will apply across all Character Areas. Aspects of wall and elevation design special to each Character Area are then covered in the individual Character Area sections.

### 6.9.1 Brick

The built fabric of York Central is to have a robust character inspired by the industrial railway buildings on the York Central site. Brick will form a significant part of the walling of “background” buildings on the York Central site, but other robust, good quality walling materials will be included in the mix. The proportions of brick to other material will vary according to Character Area as shown in the diagram below.

Walling materials will share a similar colour range. Precedents for brick colours in this range include the existing brick railway sheds in the York Central site (deeper reds and browns), the Victorian terraced housing on the site and nearby (grey-buff), and Georgian industrial-domestic buildings on the riverfront (mottled pale reds, orange-grey).

### 6.9.2 Other materials

Other materials may be used in combination and contrast with brick, such as stone, high quality pre-cast concrete. Materials such as metal, terracotta or timber may also be employed. Innovative sustainable materials such as integrated photo voltaic cells are also encouraged.

The predominance of brick varies according to Character Area as shown below. Refer to each Character Area for details.

### 6.9.3 Texture and quality

The quality of the frontages in York is as much about texture and depth, as the colour or pattern of material. The alternative materials have been selected for their *textural* qualities.

More than simply the materials selected, the quality of the building facades will rely on how the materials are used and the way they are put together.



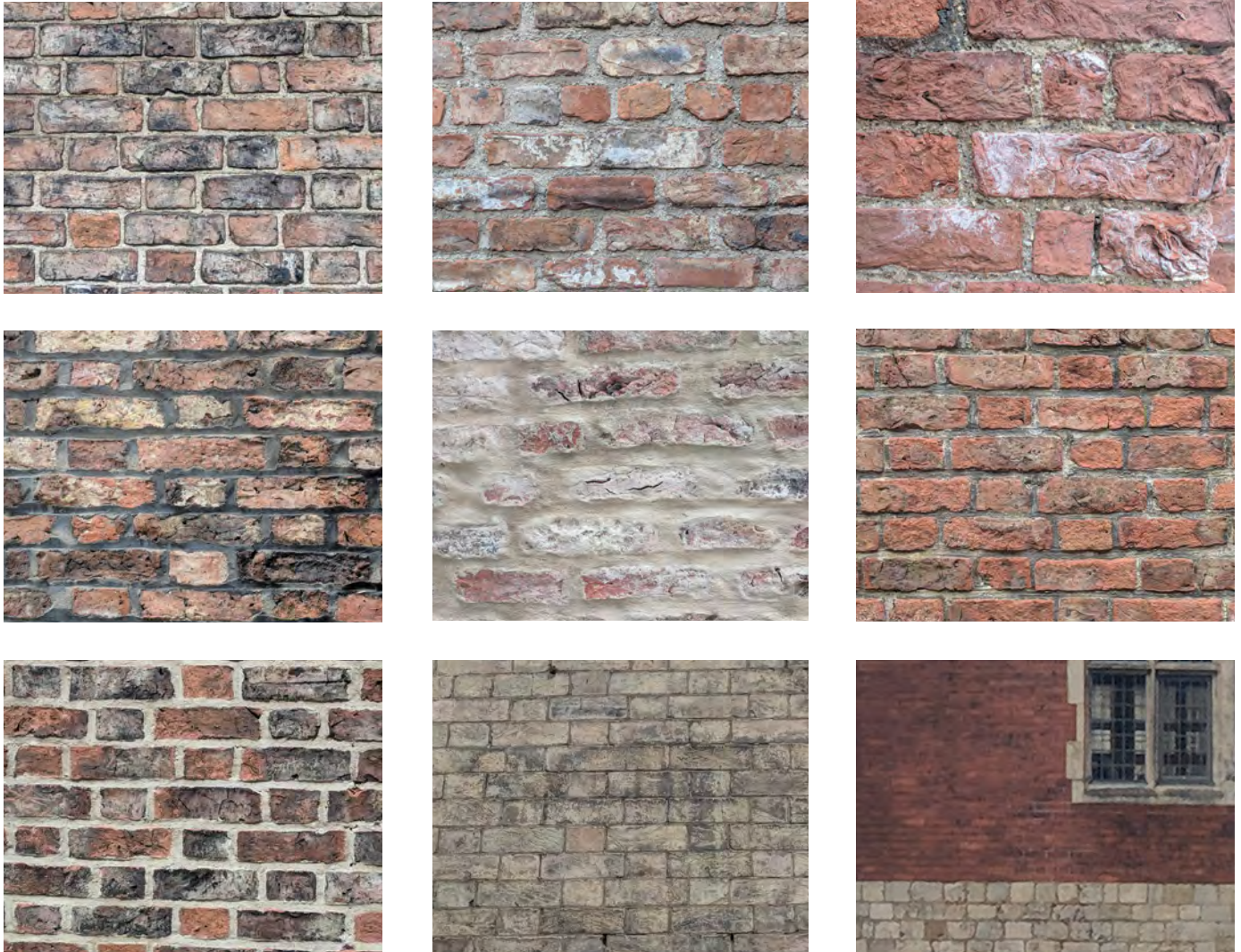

Fig.332 Selected examples of existing walling materials in York



Fig.333 The colours of masonry walling in York Central shall follow a similar palette to the existing in the historic city

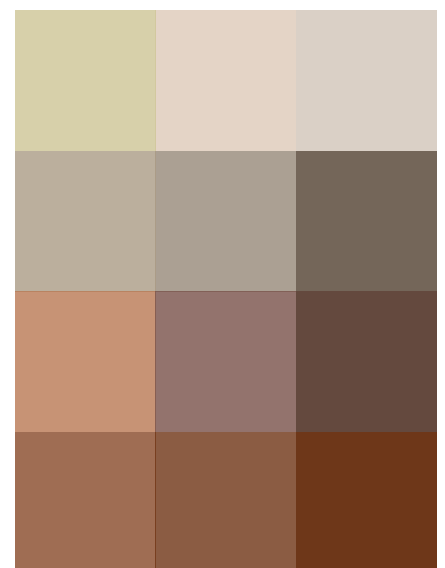
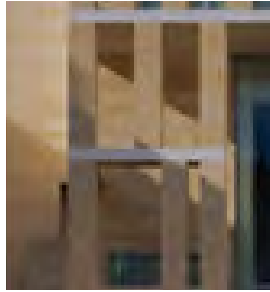

Fig.334 Colour palette for masonry walling in York Central



Stone



Terracotta



Zinc



Glazed brick

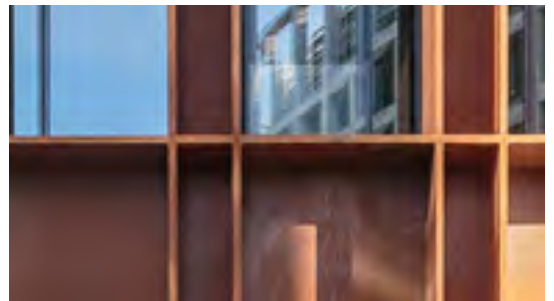

Corten

Fig.335 Examples of other (non-brick) materials which may be used for facades at York Central

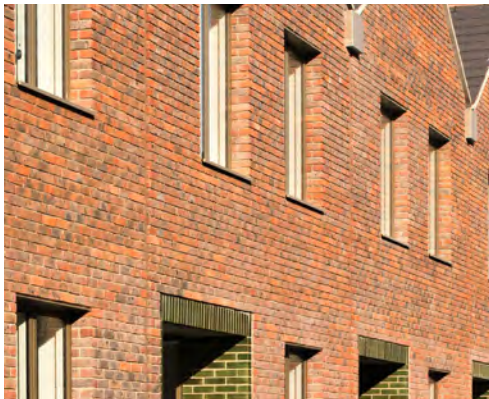

Fig.336 Examples of bricks and colours



Fig.337 Examples of colours of modern brickwork for York Central

#### 6.9.4 Brick detailing

The existing industrial buildings employ a range of brick details which help articulate the facades. Corbels, dentils, moulded bricks, pilasters, recessed panels, contrasting bands and string courses, rubbed brick window surrounds, segmental arches, flat arches – all add richness to even the humblest of the historic industrial buildings. The railway worker housing terraces on Garfield Terrace and nearby Streets use a contrasting brick as dressings to window surrounds.

**New buildings in York Central shall use a range of brick details to articulate and enrich the facades in 2 and 3 dimensions, and in a contemporary manner. This detailing shall be integrated with the overall modelling of the frontages.** (Refer to Character Areas for guidance on modelling)

Articulated brickwork may be used to provide texture and interest to facades.

**Windows on masonry buildings shall always have a reveal depth from the face of the wall of no less than 1 full brick (215mm) on buildings up to 3 storeys and 1.5 full brick length (327mm) above 3 storeys. This is to ensure that facades are modelled and buildings appear robust.**



Example of modern relief pattern to enrich brick facades



Example of cill and head details, and brick recesses used to articulate brick facades

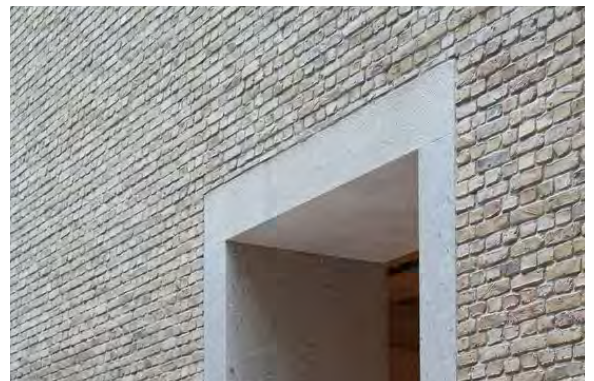

Example of a contrasting masonry material used to frame openings in brick walling



Example of a deeply articulated brickwork giving texture and depth to a facade surface

## 6.10 WINDOWS

This describes the site wide approach to the window design in York Central. It includes a description of the range of window materials which may be used across the whole of the site, and the typical details which apply across all Character Areas. Windows special to each Character Area are then covered in the individual Character Area

### 6.10.1 Arrangement and proportion

For all building types, the following general rules apply

**The arrangement of windows in brickwork walls shall, on the whole, be regular or have a regularly repeated pattern relating to the elevation bays**

**Windows will generally have a vertical (portrait) proportion rather than horizontal (landscape) proportion - in the window opening form and/or the fenestration pattern.**

**Window placement shall respect, correspond to and emphasise the elevational bays**

**Within each block, there shall be a degree of alteration and manipulation of window type, size, spacing, and subdivision to achieve the "uniform irregularity" desired across the site.**

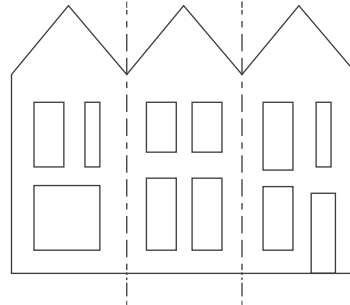

Fig.341 Regular window arrangement but with some variation

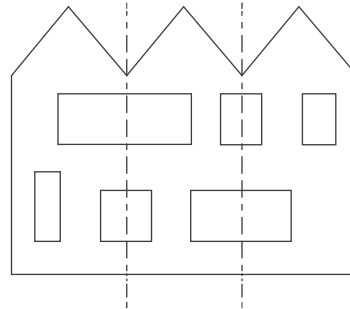

Fig.342 Window arrangement does not respect elevation bays

### 6.10.2 Material, colour and pattern

Materials used for window framing may be timber, aluminium, or steel.

Colours of window framing may be varied across the whole of York Central, reflecting the variety found in the surrounding city.

There may be a variety of fenestration patterns across York Central.

**Fenestration shall be contemporary in detail.**

**Window framing shall generally emphasise the vertical proportion, either in the form of the opening or the fenestration pattern.**

**There shall be no leaded lights, nor stuck-on glazing bars.**

**UPVC will not be acceptable.**



Fig.340 Metal-frame windows



Metal-frame windows



Fig.339 Timber-frame windows



Fig.338 PVC windows and/or leaded lights





## 6.11 BAY WINDOWS

This describes the site wide approach to the design of bay windows in York Central. It includes a description of the typical details which apply across all Character Areas. Bay windows special to each Character Area are then covered in the individual Character Area

### 6.11.1 Bay windows

Bay windows contribute to the “high degree of articulation of the street frontages in York” (Heritage Topic Paper). Within the walled city bays are often combined with jettied upper floors in medieval buildings. Bay windows to upper floors include delicate, shallow curved and canted bays to Georgian buildings. Bulkier Victorian masonry bays modulate facades at ground and upper floors.

- Bay windows may be used at ground floor or first floor level only, or
- Bay windows may form a tall stacked bay at more than one floor, but
- Bay windows shall generally not be used at topmost floor on buildings of 3 storeys or more
- **Bay windows will be contemporary in detail**



Fig.343 Bay window at Accordia, Cambridge



Fig.344 Bay windows at South Gardens. London

### 6.11.2 Jettied floors

Historic buildings on the Shambles, Low Petergate and Stonegate all offer examples of jettied floors, sometimes combined with bay windows. All building types may use jettied floors, in combination or not with bay windows (all within the Development Plot envelope).

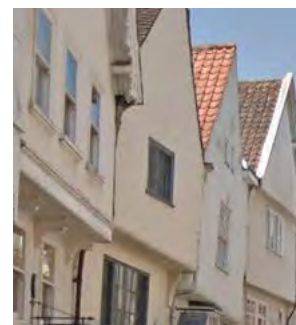

Fig.345 Examples of traditional jettied floors in York



A historic jettied floor in York



Fig.346 Example of contemporary jettied floors

### 6.11.3 Balconies

Precedents in the historic city include Georgian and Victorian balconies on industrial warehouses as well as houses. Some balconies are cantilevered or on brackets with lightweight balustrades, some sit above or are integrated with bay windows and porches. These precedents shall be interpreted in a contemporary manner for York Central.

**Balconies shall be used for York Central residential buildings to help modulate and layer the facades.**

**Residential buildings of all types shall make use of the following balcony types:**

- **Projecting**
- **Recessed**
- **Juliette**

Glass balustrade may only be used for recessed balconies where glass is in the same plane as windows.

**Glass balustrades shall not be used for projecting or juliette balconies.**

Metal balustrades are encouraged as being in keeping with the industrial heritage of the railway site, and the tradition of metalwork balustrades in York.

**Balustrades shall be contemporary in detail**

**Refer to Chapter 07 for guidance on how balconies may be used in each of the Character Areas.**

### 6.11.4 Balcony arrangement

**A combination of different balcony types shall be used to give “uniform irregularity” to the frontages to the park, streets and courtyards.**

**Balcony types shall be used to help delineate the elevation bays, emphasising the vertical bay divisions rather than horizontality of frontage.**

The smaller Housing Terraces and Mews should use shallow, or Juliette balconies, rather than deep projection balconies.



Fig.347 Projecting balcony



Fig.348 Recessed balcony



Fig.349 Juliette balcony

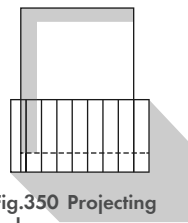

Fig.350 Projecting balcony

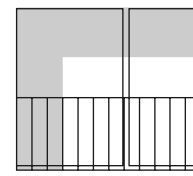

Fig.351 Recessed balcony

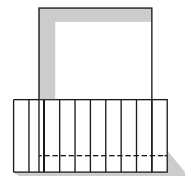
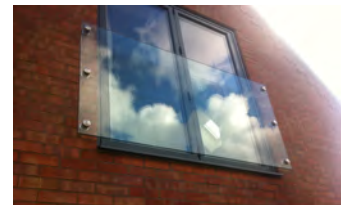

Fig.352 Juliette balcony



Glass balustrade in the same plane as windows ✓



Glass balustrade to juliette balconies ✗



Glass balustrade to projecting balconies ✗

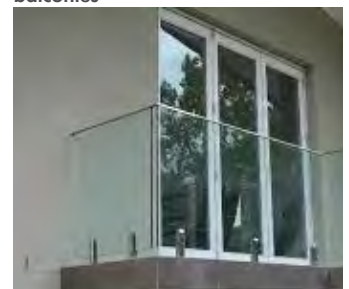

Glass balustrade to a projecting balcony ✗



Fig.353 Examples of contemporary design metal balcony balustrades



## 6.12 SHOPFRONTS

This describes the site wide approach to the shopfront design in York Central. It includes a description of the range of materials which may be used for shopfronts across the whole of the site, and the typical details which apply across all Character Areas.

### 6.12.1 Shopfronts

York contains a variety of good quality “frames” around shop windows providing visual support to the building above whilst allowing interaction with the street. Historic shopfronts are associated with smaller retail premises.

Shopfronts frames shall be in metal or timber.

**Shopfronts in York Central shall continue the scale, quality and variety of the historic frames, but reinterpret these in a contemporary manner.**

**Shopfronts shall provide variety in signage, use of awnings, fascias, positioning of signs.**

Awnings may be used.

**Shopfronts shall respect the elevational bays of the host building.**

**Shopfront fascias shall not dominate buildings facades.**



Fig.354 Examples of York city centre shopfronts

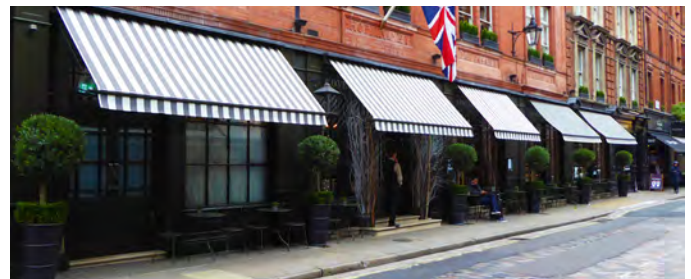

Fig.355 Example of a shopfront which respects the bays of this host building



Fig.356 Shopfront fascia dominates building





Fig.357 Example of a modern city centre street frontage showing varied signage, fascias, positioning of signs, use of awnings ✓



Fig.359 Individual contemporary shopfront design encouraged ✓



Fig.358 Example of a double height shopfront ✓



Fig.360 Individual contemporary shopfront design encouraged ✓

**6.12.2 Shopfront signage**

Signage shall be either hand-painted, or in deep relief

Hanging or projecting signs may be used

There shall be no flat vinyl banner signs



Fig.361 Signage in relief ✓



Fig.362 Hand-painted signs ✓



Fig.363 Hanging signs ✓



Fig.364 Projecting signs ✓



Fig.365 Hanging signs ✓



Fig.366 Vinyl signage ✗

## 6.13 INTEGRATING PUBLIC INFRASTRUCTURE AND BUILDING SERVICES

Ongoing maintenance of public infrastructure is essential. The visual appearance of structures providing access to this infrastructure for essential maintenance often undermines the qualities of a place. Integrating public infrastructure to avoid this is important and this section provides guidance in this regard.

### 6.13.1 Electrical substations

Where required, electrical substations shall be so located within the landscape as to be accessible by required maintenance and service vehicles whilst not detracting from the surrounding public realm.

Where electric substations are required in close proximity to residential neighbourhoods and public open space such as Central Park and New Square, they shall be sensitively integrated into the surrounding landscape so as not to introduce a negative character into the area and deter from public enjoyment of spaces. Examples of sensitively integrating substations would include constructing boundary treatments from materials appropriate to the surroundings or ensuring that boundary treatments contribute to ecological habitat corridors through hedge planting. **Where possible, electrical substations shall be integrated into building envelopes.**

### 6.13.2 Electrical junction boxes

Where required, electric junction boxes shall be so located as to not negatively impact upon the legibility or enjoyment of streets, residential neighbourhoods or public open spaces. Ideally junction boxes shall be situated against either hard or planted backdrops so as to lessen the visual impact of such elements. Junction boxes shall not be situated in close proximity to surrounding lighting, signage or street furniture so as to reduce visual clutter.

### 6.13.3 Manhole covers

Manhole covers shall be required across a range of situations including within street carriageways, footpaths and public open spaces. **The approach to manhole covers shall be based upon context, e.g. covers within footpaths or public spaces shall, where possible, utilise inset covers so designed as to seamlessly blend into the hard landscape.**

Where inset covers are used, paving shall be so laid and where necessary cut as to avoid unsightly or awkward transitions between covers and adjacent paving.

### 6.13.4 Electric vehicle charging points

Charging points for electric vehicles shall be sensitively integrated into the street design so as not to introduce a negative character into the area and deter from public enjoyment of spaces.

### 6.13.5 Services on facades

No cable runs or piped services shall be visible on facades. Rainwater downpipes are an exception to this guideline, integrated into the design of the facades.

### 6.13.6 External lights

Full integration of external lighting to buildings is encouraged in order both to minimise future retrofitting and to use buildings and their entrances, parking areas and side lanes to contribute to a legible, safe night time environment in the neighbourhoods.

### 6.13.7 Utility meters and boxes

**These shall be concealed behind architectural over-panels with robust closing and locking mechanisms, and fully integrated within the building walling where visible from the public realm.** The location of meters away from the plane of the main building facade is encouraged.

Passages shall be gated.

### 6.13.8 Dishes and antennae

A standard detail is encouraged to enable fixing of these if required. Dishes shall not be visible from the common domain, and shall always be fixed at the rear of buildings or a setback position at roof level. **These shall be concealed behind architectural over-panels with a robust closing and locking mechanism, and fully integrated within the building walling where visible from the public realm.**

### 6.13.9 Vents and flues

**These shall not be located on front facades. Vents and flues shall be routed to roof level where possible, set back from the building edge and integrated with the architectural design of the roofscape.**



Fig.367 Iron channel drain



Fig.368 Iron channel drain



Fig.369 Manhole cover



Fig.370 Manhole cover



Fig.371 Manhole cover



Fig.372 Manhole cover



## 6.14 PLOT BOUNDARIES AND FENCES

Fences shall not be placed where there are additional security measures and only where absolutely required.

As a rule security shall be achieved via window locking mechanisms. Barriers shall not be used as a security measure, principles of Crime Prevention Through Environmental Design (CPTED) should be considered.

Fences shall be in a palette in keeping with the surrounding context.



Fig.373 Barriers shall only be placed where required (note here the security grilles already over the windows)



Fig.374 Defensible spaces should only be demarcated where they form residential amenity



Fig.375 Railings should be designed to be in harmony with the landscape design







Fig.376 Screen and hedge



Fig.377 Timber screen



Fig.378 Wattle screen



Fig.379 Timber screen

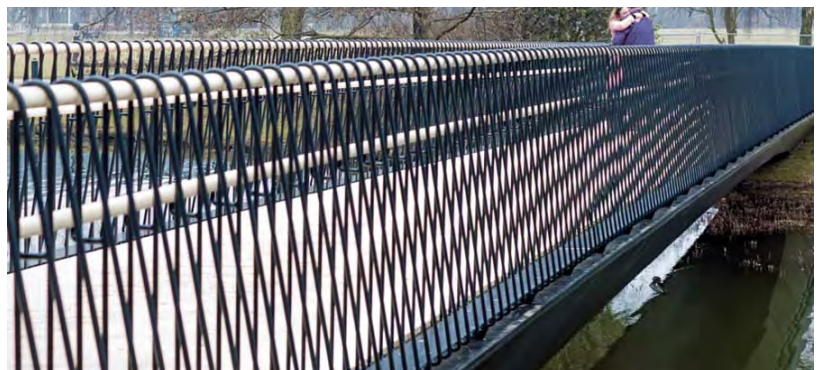

Fig.380 Examples of possible railings between Hudson Boulevard and Museum South Yard



## 6.15 SITE PERIMETER FENCES

### 6.15.1 Perimeter fences

Refer to Section 3.10.1 for performance requirements.

**Vertical bar – steel palisade fences, while these confirm to Network Rail standards, will not be acceptable on York Central in terms of appearance.**

**All perimeter fencing should be painted or coated in a dark colour to merge with the adjacent landscape.**

**Where needed next to railway lines, fences shall be as discreet as possible.**

Powder coated finishes are acceptable.



Fig.381 Green mesh blends into landscape. Fence to railway, Millwall



Fig.382 Palisade fencing is un acceptable. Raw steel/metal finishes are not appropriate

## 6.16 PARKING AND CYCLE STORAGE

### 6.16.1 External Parking areas

Parking areas shall be small scale, with parking bays grouped but separated and subdivided by soft landscaping.

The design of carparks shall be cognisant of the visual aspect from residential areas.

Carparks must be well overlooked.



Fig.383 Car park subdivided with soft landscaping



Fig.384 Car park hardscape only and many cars parked together



Fig.385 Car park hardscape only and many cars parked together





## 7 APPEARANCE BY CHARACTER AREA

This section discusses how different spaces and buildings within the site can be articulated. It sets out guidelines which discuss the composition of different building elements, materiality, proportion, palettes of materials and guides the qualitative aspects of the appearance of public spaces and buildings.

## 7.1 INTRODUCTION

This chapter covers aspects of the appearance of York Central's buildings that are specific to each Character Area. It should be read in conjunction with Chapter 06 Appearance Site Wide.

This chapter contains guidelines on how buildings in each Character Area may contribute to the desired balance of consistency and diversity that characterises York - the "uniform irregularity" described in Chapter 06. Guidelines for each Character Area suggest how each Development Plot may achieve this through modelling and facade composition, particular details and material palette.

The role of "foreground" buildings in each Character Area is also outlined.

### STATION QUARTER\*

- 14 George Square
- 15 Cinder Yards
- 16 Station District
- 17 Wilton Place (a), Cinder Street (b) and Hudson Place (c)
- 18 Station Gateway (south half of New Square)

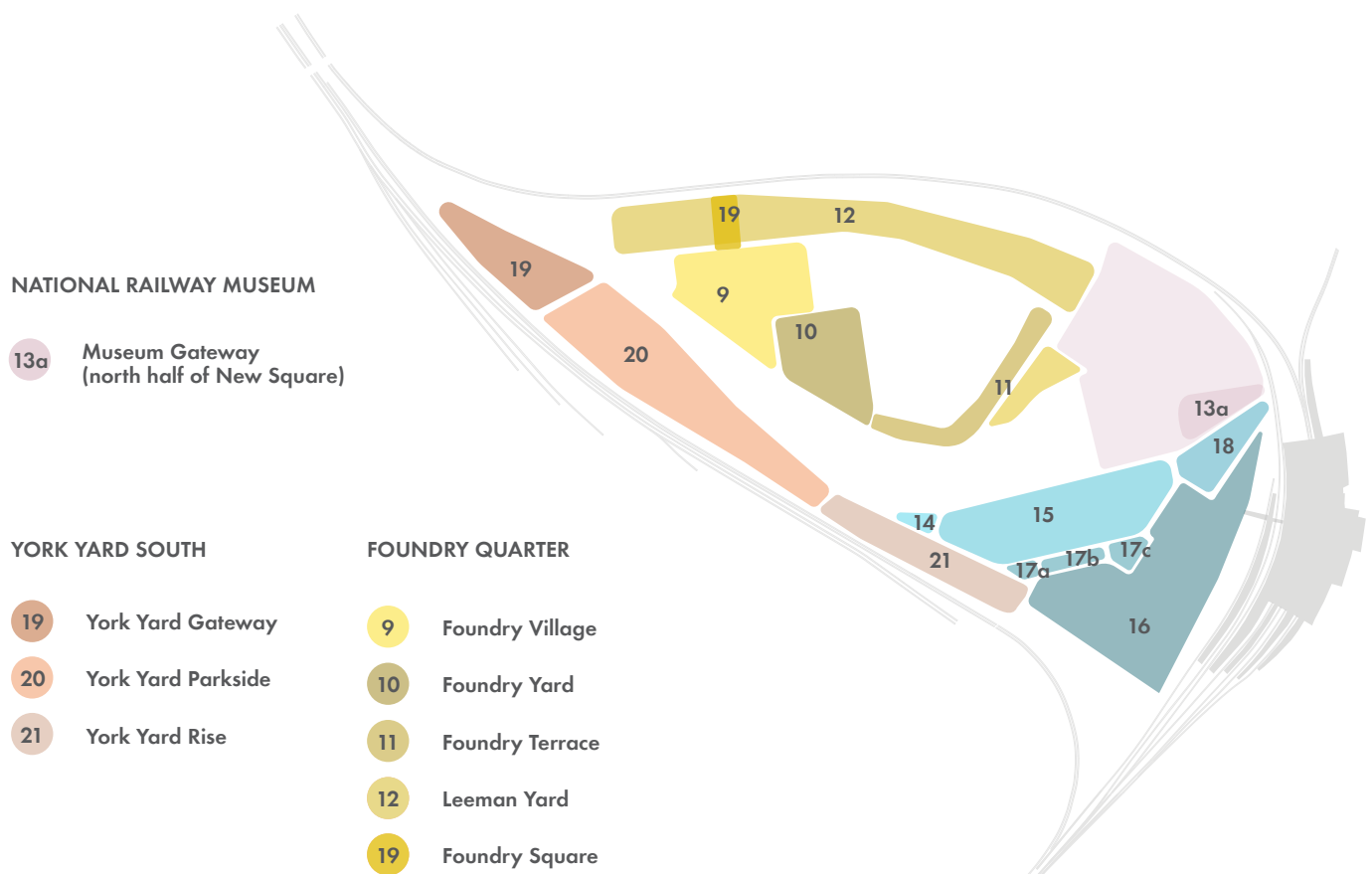

\* spaces and numbering associated with the existing National Railway Museum buildings and Central Park have been omitted.

## 7.2 STATION QUARTER

The Station Quarter will become a new high quality urban district for York that is set around the historic and nationally significant National Railway Museum and station. Spaces and buildings in this quarter will draw on the industrial heritage of the site and the wider city.

### 7.2.1 Life in Station Quarter

Adjacent to York railway station, this will be the arrival space for visitors to York and to York Central and will form a new destination for businesses, for tourists and for local residents alike.

The Station Quarter will be defined by its high quality public space - Station Gateway, Cinder Yards, Hudson and Wilton Place and foot streets - Hudson Boulevard, Hudson Lane and Wilton Lane. A range of commercial spaces, homes, retail offerings, cafés/restaurants, hotels and leisure uses will create a vibrant new destination for the city which will be active throughout the day and into the evening.

#### STATION QUARTER

- 14 George Square
- 15 Cinder Yards
- 16 Station District
- 17 Wilton Place (a), Cinder Street (b) and Hudson Place (c)
- 18 New Square



## 7.2.2 Character of Station Quarter

Station Quarter will be the high quality urban district for York set around the National Railway Museum and the historic station. Both residential and commercial, the spaces and buildings in this quarter will draw on the industrial heritage of the site and the wider city, using as precedents the muscular industrial buildings associated with the railways.

Models for the Station Quarter buildings include the brick railway sheds and front of house buildings, but also the factories and warehouses built further along the river – Nestle, Rowntree and Terry's.

**These buildings will form the 'background' buildings of the Station Quarter.** They will have a regularity of form each having its own predominantly regular rhythm of bay sizes and window spacings.

**Buildings shall not turn their backs to the railway line, but must consider views and setting when viewed from station platforms and the city walls.**

The roofscape and roofline will be modelled and articulated to nestle in with the wider city.

**The design of buildings shall be cognisant of their appearance from outside York Central.**

For Station Quarter, important views include those from the city walls and from trains arriving into York Station.



Fig.387 Friargate, Coventry, precedent for commercial building commercial buildings



Fig.388 Thornsett Road, London, precedent for commercial building

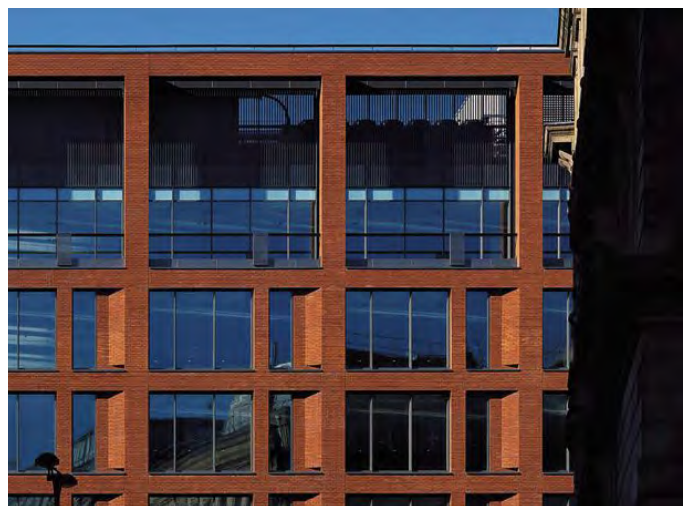

Fig.386 No. 1 Piccadilly Gardens, Manchester, precedent for commercial building





### 7.2.3 Uniform irregularity

Individual buildings will be predominantly regular in arrangement, although the massing of blocks should be somewhat irregular and shall contribute to the overall “uniform irregularity” of the Station Quarter.

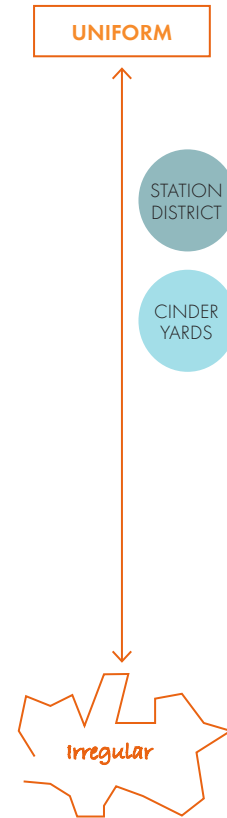

### 7.2.4 Grain

York’s large footprint industrial buildings offer a precedent for commercial buildings in the Station Quarter and their the scale will suit the new business uses proposed for York Central. But the streets and urban spaces shall have more in common with the tighter grain of the historic city than the industrial scale spaces formed by factories and rail sheds. The rhythm and modulation of the facades in the Station Quarter shall reflect the tighter grain of the historic city, and contribute to the ‘human scale’ spaces formed between the new buildings. Anonymous “business park” type spaces are to be avoided.

The grain of this character area shall arise from:

**Large urban blocks formed of large, regular footprint buildings**

**Enclosed, connected yards**

**Framed urban spaces and enclosed streets**

**Small secondary routes through and between blocks**



Fig.389 Grain - Station Quarter

## 7.2.5 Roofs

**Pitched and flat roofs shall be used in combination in the Station Quarter.**

Pitched roofs to commercial buildings shall reflect the robust, industrial character of the buildings in this quarter, and have a regular rhythm and grain. Gables shall be orientated to the main street and to prominent frontages to enliven the roofline in combination with parapets. Alternatively dormers shall be used to this purpose.

**Flat roofs shall be “brown” or “green” roofs or occupied terraces. The rooflines of flat roofed buildings shall be articulated through changes in level, setbacks.** Open framed parapets may be used to further articulate the roofline.

**No roof top plant roof shall be visible from low or high level views.**

**Multi storey car parks shall have roofs. Cars will not be visible on the top deck.**

Like the other roofs in the Station Quarter, roofs to multi storey car parks will be a combination of pitched roofs, planted terraces or shared, communal, occupied terraces.

## 7.2.6 Roof materials

As Chapter 06 Appearance site wide



Fig.390 Flat roof set back



Fig.391 Pitched roofs



Fig.392 Dormers



Fig.393 Open framed parapets



Fig.394 Stepped parapets



Fig.395 Flat roofline (except on access roads)





Fig.396 Example of combination of pitched and flat roofs - zoom in on Station Quarter from the Illustrative Scheme



Fig.397 Pitched roof with 'chimneys' and inverted dormers



Fig.398 Open parapet



Fig.399 Pitched roof with dormers and cropped ridge



Fig.400 Regular pitched gables



Fig.401 Occupied flat roof terrace



Fig.402 Regular repeated pitched roof form

Examples of contemporary roof forms which would be acceptable for Station Quarter



**7.2.7 Gutters and downpipes**

The quality of roof edges will be critical in defining the quality of the streets in Station Quarter

**Exposed gutters and downpipes shall be avoided on the primary frontages of buildings in the Station Quarter. Parapet or secret gutters shall be used.**

The preference is for concealed downpipes on all elevations. However, any exposed downpipes should be positioned on side elevations rather than primary frontages.

**Exposed downpipes shall be integrated into the facades design.**

**Any visible gutters and downpipes shall be metal (UPVC will not be acceptable)**

**7.2.8 Eaves, parapets, gables and verges**

**Buildings within the Station Quarter shall have parapets or eaves with modelled profile which forms a positive cornice line seen from the street.**

**Alternatively, buildings within the Station Quarter shall have parapets or projecting verges that contribute to the modelling of the roofline.**

**The new buildings within Station Quarter shall employ a range of contemporary masonry parapet details to enrich the skyline seen both from within York Central and beyond.**

**Buildings whose tops are seen from the city walls, rising above the train shed roof of York station, shall have a distinctive parapet incorporating openwork through which sky can be seen.**

**There shall be no thick box eaves or verges on any building.**

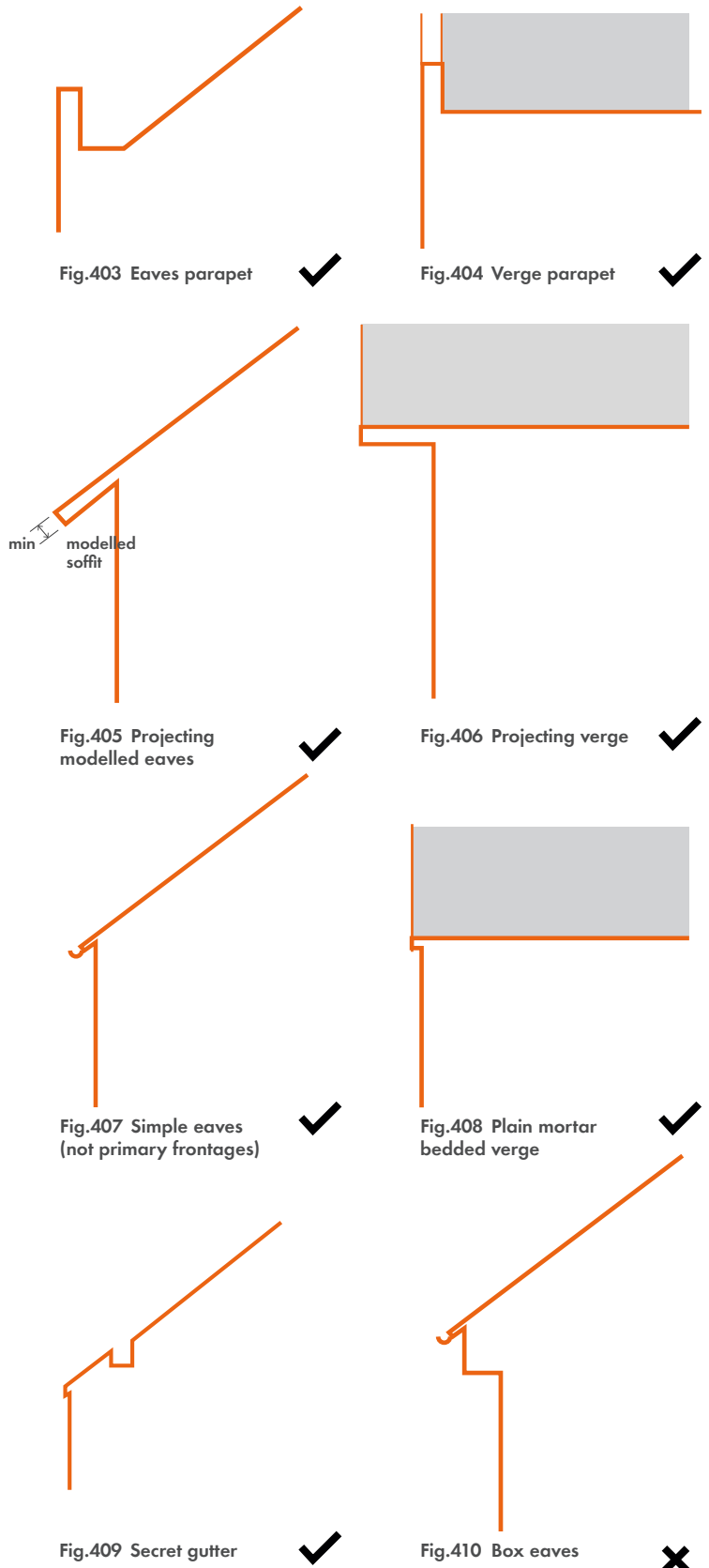

### 7.2.9 Facades

The facades of the Station Quarter buildings 'background' buildings will be predominantly regular in arrangement, although the massing overall in the Station Quarter shall exhibit overall the "uniform irregularity" which characterises York's city fabric.

Facades in the Station Quarter will exhibit the robust character of the industrial buildings found in York and on the site, but will be detailed with the "human scale" characteristic of the inhabited fabric of the historic city.

Commercial Buildings forming the background to public realm in Station Quarter shall present a contemporary interpretation of York's industrial typologies, re-presenting the characteristics shared by the factory and warehouse precedents:



Terry's Chocolate Factory



Rowntree Factory



Bonding Warehouse



Bonding Warehouse

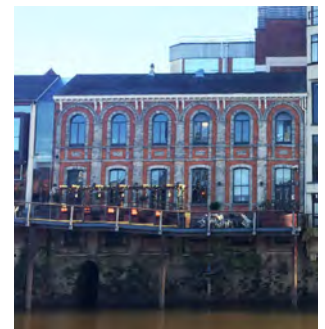

Ebor Hall on the Ouse

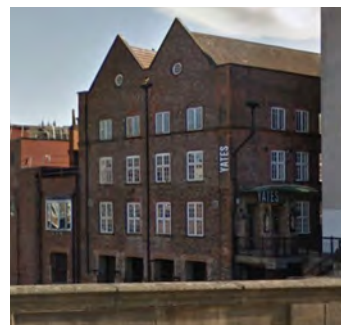

Warehouse building on the Ouse



Yorkshire Herald building

Fig.411 York traditional precedents for industrial and commercial buildings



Fig.412 Friargate, Coventry

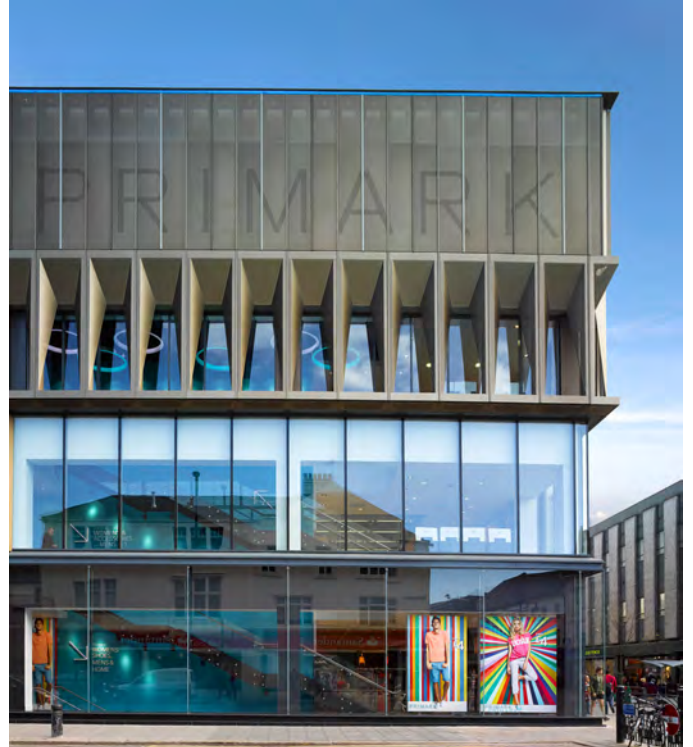

Fig.414 Primark, Newcastle



Fig.413 R7 Kings Cross office building, London  
Contemporary commercial buildings

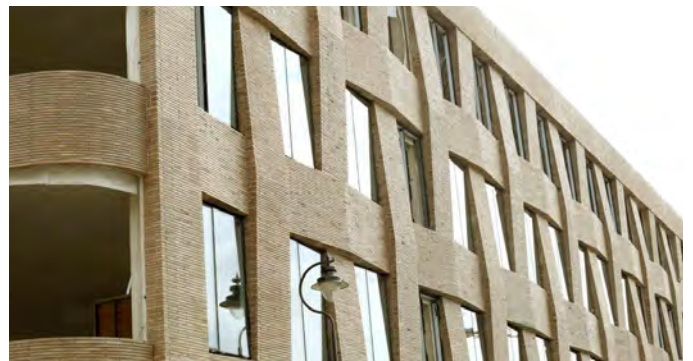

Fig.415 Hungate, York



Fig.416 St Martin's Court, St Paul's, London

---

### 7.2.10 Overall form

**Station Quarter commercial buildings**, with generally larger footprints suitable for modern office floor-plates, **will present themselves as whole buildings.**

**Facades, although modulated and articulated, will not pretend the building is composed of apparently much smaller plots.**

Guidance for the *residential Mansion Blocks* in Station Quarter shall follow the guidance for the Mansion Blocks in York Yard South under section 7.3.

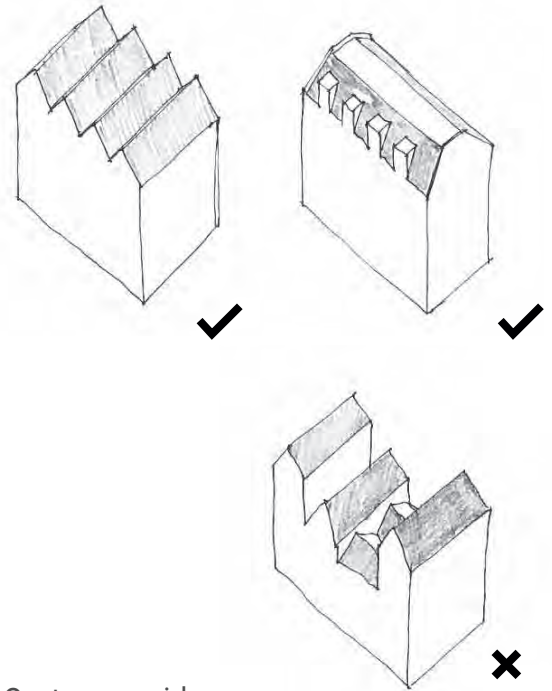

Fig.417 Station Quarter commercial buildings as 'whole buildings'

---

### 7.2.11 Facade composition

**Facades are to have a base, middle and top**

Within the middle band, there may be emphasis on windows to the first floor

**The top is to be differentiated, for example through smaller windows to topmost floor, open parapets, modelled parapet and/or a projecting cornice**

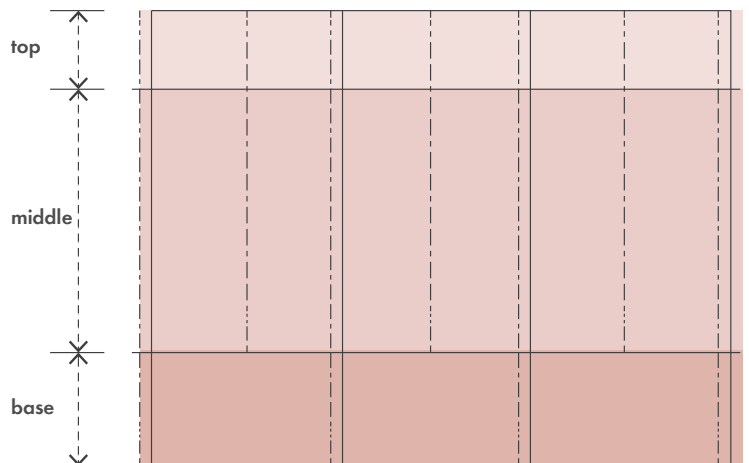

Fig.418 Facades with ground floor base, middle and top





**7.2.12 Facade articulation**

Window openings in the wall shall be generally regularly spaced.

The rhythm of vertical bays shall be expressed (or implied through window rhythm).

Variation in floor heights between adjacent buildings, and expressing this in their facades, is encouraged. This is to vary the rhythm of frontages, and contribute to the “uniform irregularity” of Station Quarter.

There shall be further articulation of bays on long buildings (bays brought forward or pilasters projecting).

The entrance and corner bays shall be articulated on longer facades.

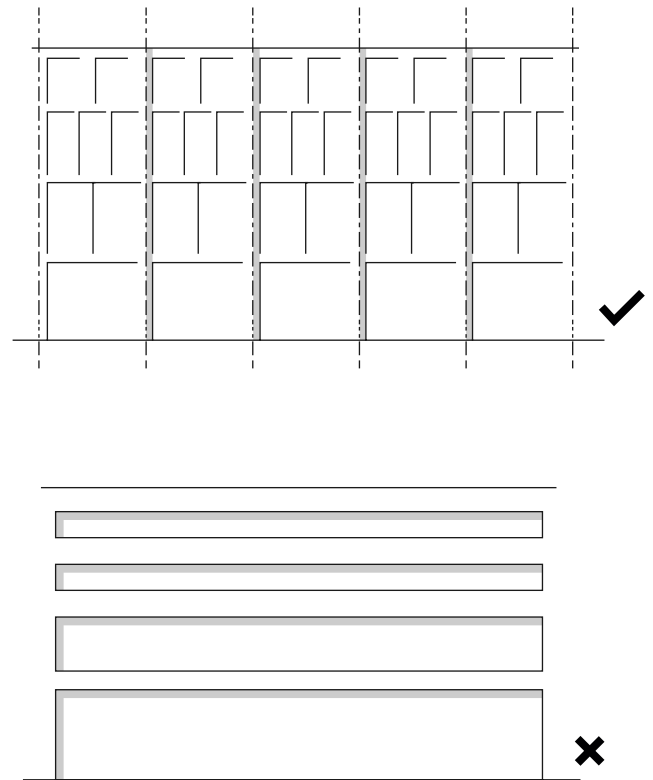

Fig.419 Examples of Station Quarter facade articulation

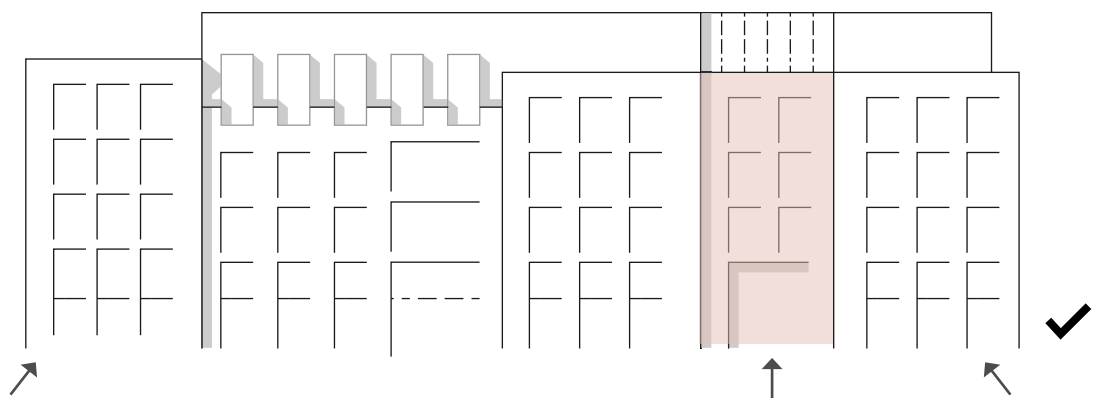

Fig.420 Example of Station Quarter facade articulation, emphasising entrance bays, corner bays

### 7.2.13 Facade materials

Street facades in the Station Quarter will exhibit the widest range of materials on York Central site.

### 7.2.14 Street frontages:

Brick walling or framing shall be the preferred material. Brick shall comprise a minimum of 30% of the solid framing material across the Station Quarter as a whole.

**Entirely glazed facades will not be acceptable on street frontages.**

However, large areas of glazing on street facades *will* be permissible providing they are framed in solid material. Terracotta or metal framing may be used in addition to, or as an alternative to brick.

### 7.2.15 Inner courtyard frontages

The facades of inner courtyards in Cinder Yards and the Station Quarter offer opportunities for discovering surprising contrasts - that sense of coming across a hidden delight that so characterises York.

The main walling material of the inner courtyards may differ from the main walling material of the street frontages.

**A alternative material for the inner courtyards shall nevertheless use a colour or tone similar to that of the bricks used across York Central, to give subtle contrast.**

Entirely glazed facades will be acceptable to inner yard frontages.

Rich textural materials, other than brick may be used - put together and detailed to present the same depth and quality as found in historic courtyards within York.



Fig.421 Palette of brick colours and textures

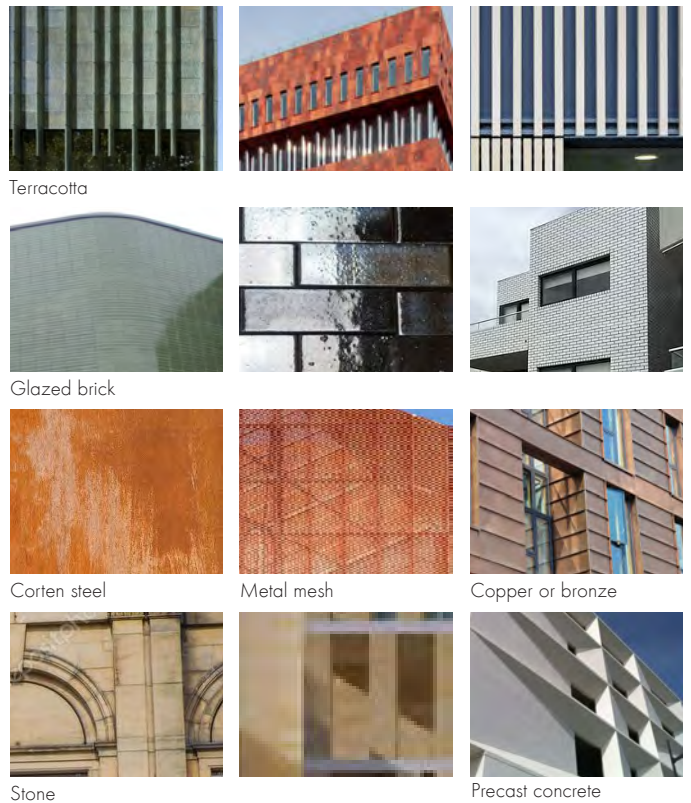

Fig.422 Palette of example 'textural' materials other than brick



Fig.423 Corten steel - Kings Cross



Fig.425 Metal sheeting, Shoreham Street, Sheffield

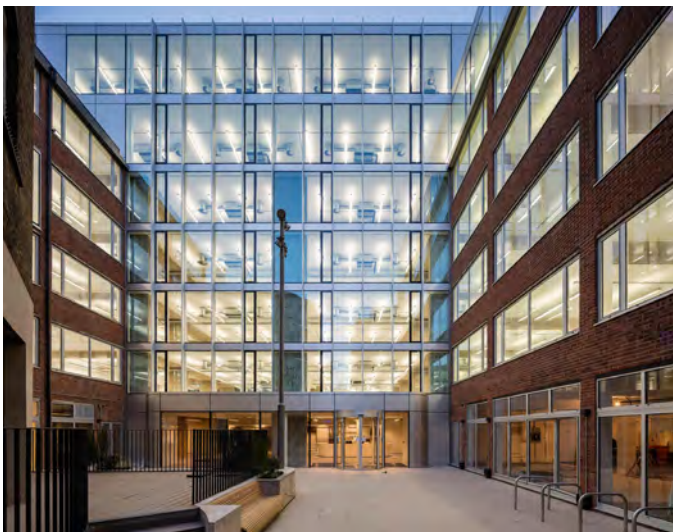

Fig.424 Fully glazed wall, Sutton Yard, Islington London

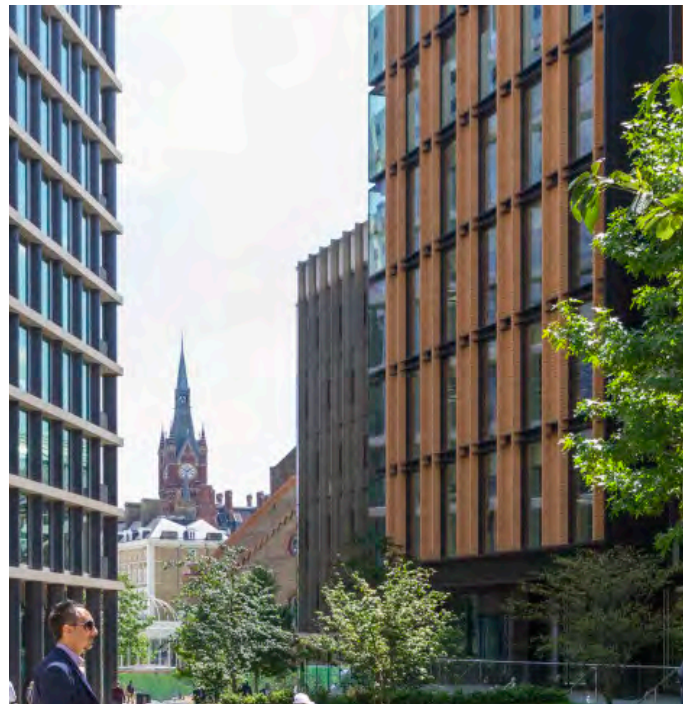

Fig.426 Terracotta

Contemporary commercial buildings whose facades include materials other than brick

## 7.2.16 Foreground buildings

Refer also to Chapter 06.

Foreground commercial buildings in this Character Area relate to public open spaces, occupy prominent positions in York Central and will be the focus of longer views on the site.

The foreground buildings in the Station Quarter shall be “city” in their appearance. F (east) on the plan right should be formal in its frontage to the square and to the boulevard. As a stop-end to the terrace overlooking the boulevard, the form may be sculptural. But it should nevertheless be integrated into the street frontages.

F (west) forms the other stop end to the terrace overlooking the boulevard. The building also forms a gateway into the Station Quarter when arriving from Central Park. The frontage offered to the park and boulevard should be formal and urban, integrated into the street frontages.

D (north) below should provide a formal, largely symmetrical backdrop to the Coal Drops, and be aligned with the Coal Drops.

D (south) and B(north) would be the focus of the ‘triangular squares’ of Hudson Place, and B(south) the focus of Wilton Place. Only one foreground building should be considered for each of Wilton Place or Hudson Place. More than one would overwhelm these small squares. These buildings help enclose these triangular squares, they should be cognisant of their role in the street scene.



Fig.427 Locations for “Foreground” buildings in Station Quarter

- Foreground building
- These buildings may be foreground
- Multi storey car parks



Fig.428 Sainsbury's Fulham Wharf, London



Fig.431 Buddhist Temple in New South Wales, Australia



Fig.429 Carpark structure, Charles Street, Sheffield



Fig.432 Riverwalk, Thames, London



Fig.430 Gunpowder Wharf, Waltham Abbey

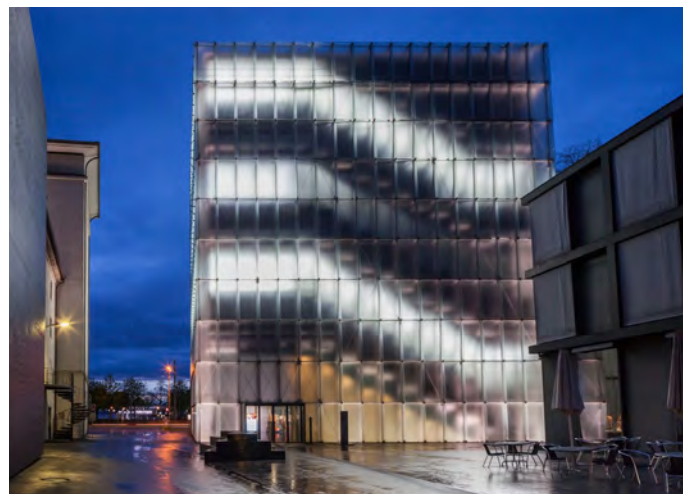

Fig.433 Kunsthaus-Bregenz

Examples of buildings which would be considered "foreground" in the station Quarter

### 7.2.17 Multi storey car parks

**Multi storey car parks shall form a positive contribution to the immediate streetscape and views of the site from the wider city context.**

Multi-storey carpark buildings should seek to avoid creating blank, dark windows to the street frontages as these deaden the street frontage.

Metal grillage or bars in window openings should not be used.

Active facades are strongly encouraged.

The use of green walls is strongly encouraged.

The use of solar Photo Voltaic panels is strongly encouraged if appropriate in the townscape context.



Fig.434 Car park



Fig.435 Car park with active facade



Fig.436 Car park with open active facade



Fig.437 Dark openings



## 7.3 YORK YARD SOUTH

York Yard south is a predominantly residential area comprising a mix of courtyard and linear mansion blocks that provide a range of apartments and maisonettes. In their appearance, the mansion blocks are the most “irregular” of the building types in York Central, reflecting the wide range of small scale domestic spaces which they contain.

### 7.3.1 Life in York Yard South

York Yard south is a residential area comprising a mix of courtyard and linear mansion blocks that provide a range of apartments and maisonettes. The area bounds the southern edge of Central Park and will benefit from views across and into the green space, and to Foundry Village beyond.

A sequence of residential streets, play streets and community gardens will connect the courtyard blocks and provide routes through the community, joining it with the park and wider site. A sequence of contemporary ‘snickets’ and lanes weave through the blocks and provide a sequence of public and semi public open spaces.

Communal rooftops will provide amenity for residents. Play streets and community gardens will act as green extensions of Central Park. Active rooftops and street facing balconies will provide passive overlooking of Play streets and community gardens.



---

### 7.3.4 Character of building frontages

This long swathe of building will form a strong, lively edge to Central Park.

The frontage to the park shall be varied along its length, achieving a “uniform irregularity” and incorporating into these substantial, predominantly brick buildings the wealth and quality of detail found in York city, which is so key to its “Yorkness”. Side facades too will offer rhythmic frontages with a diversity of detail to the play streets and community gardens between the blocks.

The rear facades seen from south of the site are as important as the parkside frontages. These facades shall be well articulated and modelled to create a sense of layering on this edge of the site and a high degree of visual permeability through to the green spaces within York Central. Facades must not appear as a ‘wall of development’.



Fig.439 Example of a neighbourhood playspace, Accordia, Cambridge

---

### 7.3.2 Grain

Mansion Blocks in York Yard South bring a new building form to the city, with an urban grain of large footprint properties and wide spaces in between. The massing of these blocks shall be broken down to reflect the scale of inhabitation, and the generally small-scale residential units within. Public realm and communal spaces in and around the Mansion Blocks, together with the snickets which thread through them, shall seed into York Yard South the intimate grain of the historic city. The historic grain of multi-building terrace plots offers a pattern for the Mansion Block street and outward-facing frontages, and the enclosure of the inner courtyards.

#### Large footprint urban blocks

**Blocks moulded to reflect multiple smaller residential units within**

**Frontages articulated to a domestic scale**

**Generous open spaces between blocks**

**Winding routes through blocks, linking open spaces**



Fig.438 Grain - York Yard South



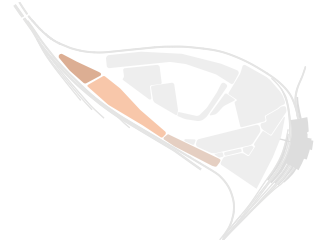

### 7.3.3 Uniform irregularity

The massing of blocks shall be notably irregular, and shall contribute to the lively modelling and “uniform irregularity” of the York Yard South.

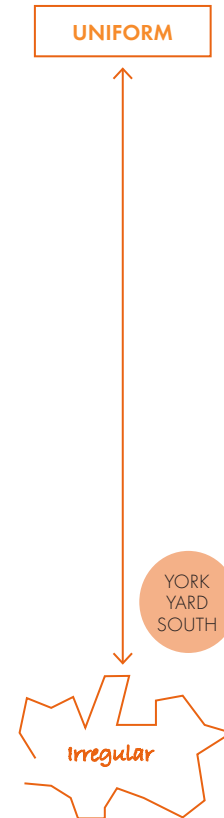

### 7.3.5 Form of mansion blocks

The massing of mansion blocks in York Yard South shall be heavily modelled and articulated to break down the scale of these residential blocks.

Being composed of smaller residential units, these large blocks shall be broken down in scale to the domestic scale and grain of the historic city. **The buildings shall present themselves as larger city blocks composed of smaller plots.**

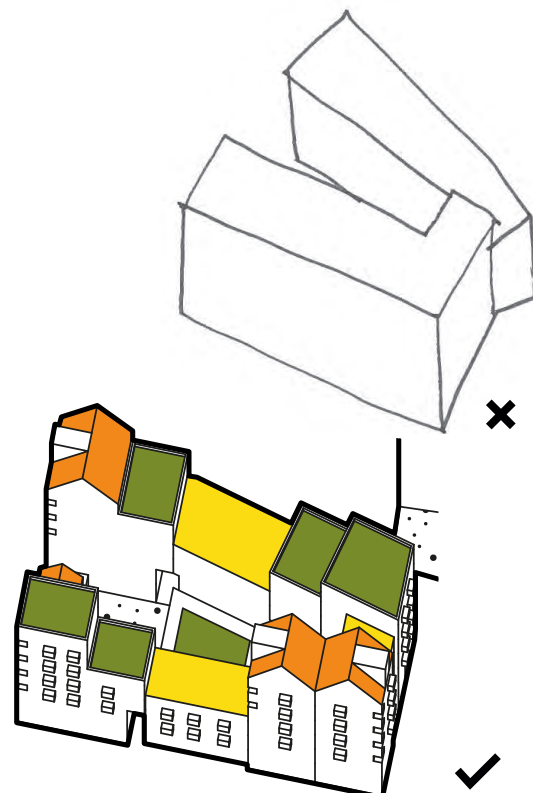

Fig.440 The massing of York Yard South buildings broken down to reflect domestic plot sizes

### 7.3.6 Roofs

Roofs to the mansion blocks shall be a combination of pitched roofs and flat roof terraces at a number of different levels and in different orientations, all together giving a “uniform irregularity” to the roofscape and roofline.

**Within each building block the roofs and terraces shall step by at least one storey on each frontage, as well as using gables and other means to achieve a picturesque and varied roofline.**

Overall asymmetry of roofline and skyline is encouraged.



Fig.441 Combination of pitched roofs and terraces at different levels (example from the Illustrative Scheme)

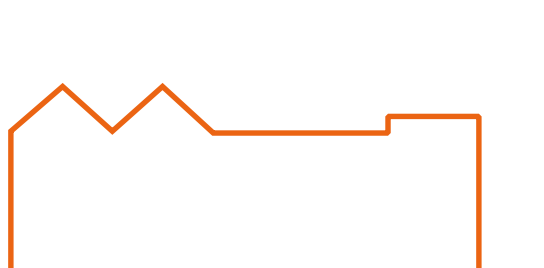

Fig.442 Roofline doesn't step at least one storey



Fig.443 Roofline steps by at least one storey

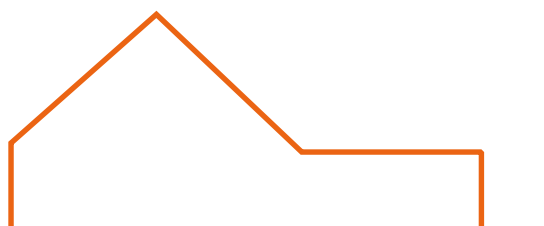

Fig.444 Gable at too large a scale



Fig.445 Symmetrical roofline with lack of variation



Fig.446 Symmetrical roofline with lack of variation

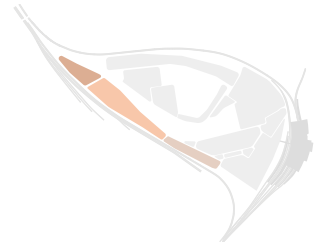

**7.3.7 Roof materials**

See Chapter 06.

**7.3.8 Gutters and downpipes**

The quality of roof edges will be critical in defining the quality of the streets in York Yard South.

**Exposed gutters and downpipes shall be avoided on the primary frontages of buildings in York Yard South. Parapet or secret gutters shall be used.**

The preference is for concealed downpipes on all elevations. However, any exposed downpipes should be positioned on side elevations rather than primary frontages.

**Exposed downpipes shall be integrated into the facade design.**

**Any visible gutters and downpipes shall be metal (UPVC will not be acceptable)**

**7.3.9 Eaves, parapets, gables and verges**

Buildings within York Yard South shall have parapets, eaves and verges with modelled profiles. These either form a positive cornice line seen from the street, or contribute to the modelling of the roofline.

There shall be no thick box eaves or verges on any building.

The new buildings within York Yard South shall employ a range of contemporary masonry parapet details to enrich the skyline.

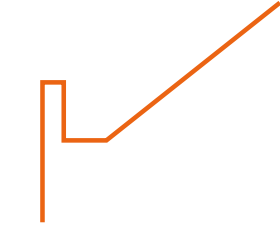

Fig.447 Eaves parapet ✓

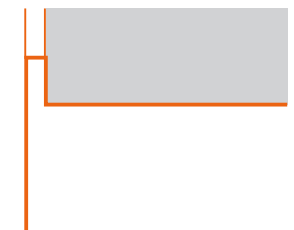

Fig.448 Verge parapet ✓

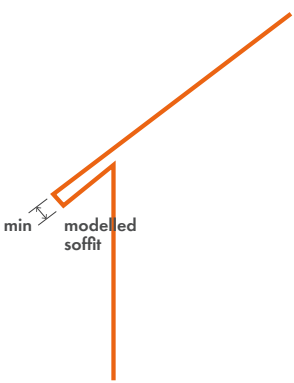

Fig.449 Projecting modelled eaves ✓

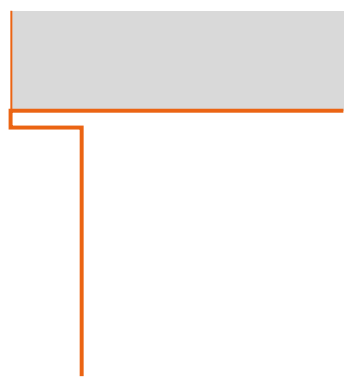

Fig.450 Projecting verge ✓

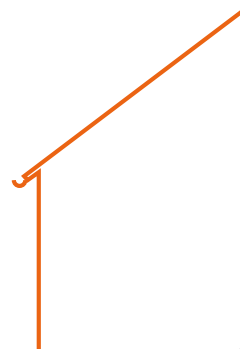

Fig.451 Simple eaves (inner courtyards only) ✓

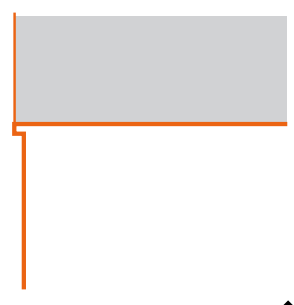

Fig.452 Plain mortar bedded verge ✓

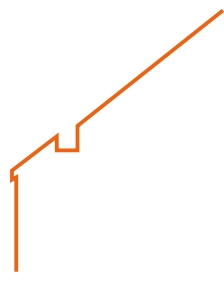

Fig.453 Secret gutter ✓

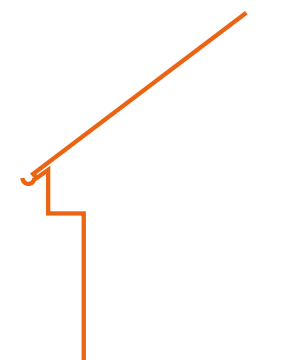

Fig.454 Thick box eaves ✗

### 7.3.10 Facades

Mansion blocks should present the same robust industrial typology as the buildings in Station Quarter, but with a much greater level of articulation and variation to bring in the “human scale” appropriate for homes and domestic spaces. Mansion blocks line the main street through York Central alongside the Central Park. This long street frontage, together with the short streets leading off from it, needs to present the same grain and texture as found in the surrounding city.

The “uniform irregularity” offered by the existing streets is largely a function of urban blocks composed of smaller individual plots. The plots in the historic city have irregular widths, different roof edges as discussed above, and often different floor heights – a sense of which is given by the slightly different window heights on the street frontage.

**The facades of mansion blocks shall be articulated to impart this sense of “uniform irregularity”**



Fig.458 Example of lively articulated brick facade, Brentford, London

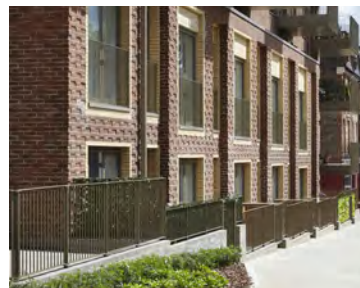

Fig.456 Example of a facade articulated with regular divisions

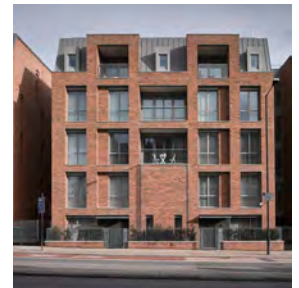

Fig.459 Example of an articulated facade

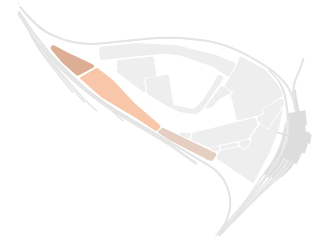

Fig.457 Example of unsuitable facade, no articulation, horizontal emphasis and poor proportions



Fig.455 Example of a facade composition not suited to York Central. Though contemporary and well detailed, the uninterrupted roofline, single plane of walling, and regular balcony placement emphasise the monolithic quality of the block.





### 7.3.11 Facade composition

**Facades shall be composed of irregular elevation bay widths.** Elevation bays may vary between 2 and 6 windows wide. 2-3 window-wide bays are the most common. 5-6 window-wide bays shall generally have a 2-3 window-wide bay adjacent to them.

**Bays shall be articulated in plan as well as elevation. An offset of at least 1 full brick depth is required between bays.** Change of walling material or colour will not be sufficient articulation on its own.

**The treatment of the facade shall help suggest that internal floor levels vary between elevation bays.**

This helps convey the sense that the block is composed of many smaller domestic-sized plots, each containing a range of different, individual homes. It helps avoid the monolithic quality of some large apartment blocks.

Visually breaking up the frontage in this way may be achieved through variation in window types, cill and head heights, spacing, the use of bay windows and balconies, together with other means. Entrances, shop fronts and porches shall all contribute to the liveliness of the frontage.

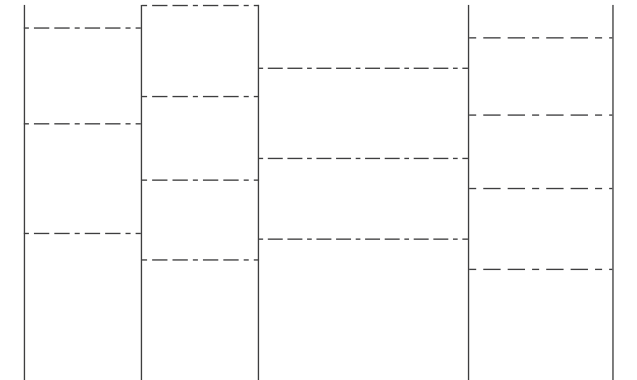

Fig.460 Diagram showing irregular facade bay widths, and implied varied floor levels

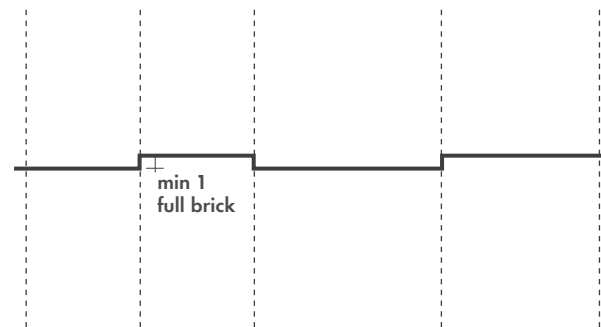

Fig.461 Diagram showing facade bays articulated in plan as well as elevation

### 7.3.12 Balconies

Refer to Chapter 06 Appearance Site Wide for guidance on design of balconies generally within York Central.

### 7.3.13 Balcony arrangement

**A combination of different balcony types shall be used to give “uniform irregularity” to the frontages to the park, streets, south facades and courtyards in York Yard South.**

**Balcony types shall be used to help delineate the elevation bays, emphasising the vertical bay divisions rather than horizontality of frontage.**

Townhouses should use shallow, or Juliette balconies, rather than deep projection balconies.

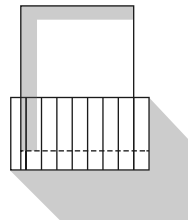

Fig.467 Projecting balcony ✓

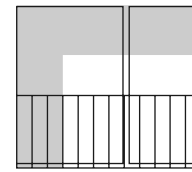

Fig.465 Recessed balcony ✓

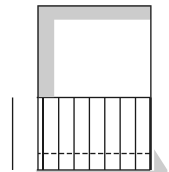

Fig.466 Juliette balcony ✓

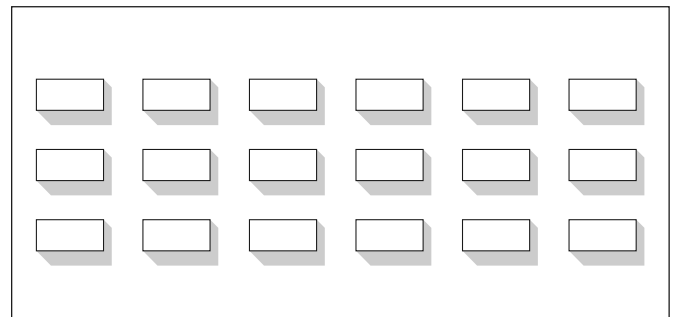

Fig.463 Monotonous regular balcony arrangement ✗

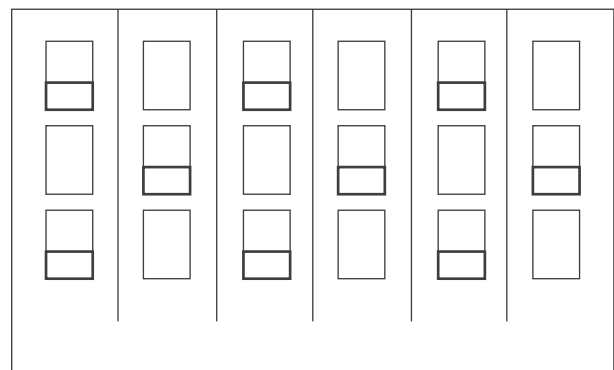

Fig.462 Monotonous regular balcony arrangement ✗

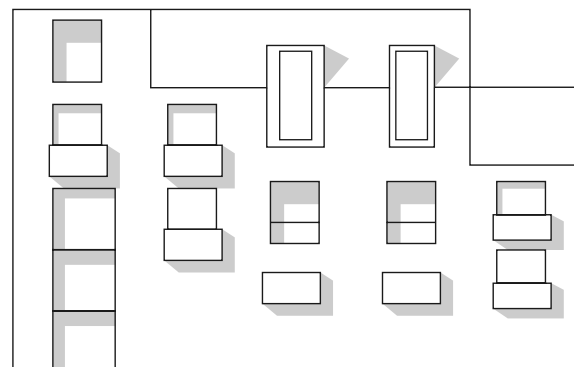
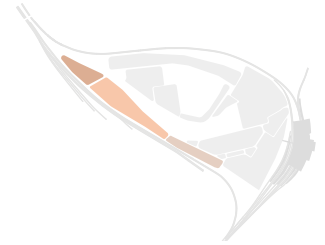

Fig.464 Example of “uniform irregularity” ✓



**7.3.14 Street facade material**

Walls to street fronts in York Yard South will be predominantly of brick, which shall constitute 75% of the solid facade material.

Other materials used in conjunction shall be of a similar tonal palette to that of the bricks used across York Central, to give subtle rather than stark contrast.

The colours of bricks shall be varied between building plots. However, each individual building in York Yard South shall use predominantly the same brick throughout.

Variations in brick colour may be used to differentiate architectural elements (such as an entrance bay). Changes in brick colour may arise through successive building phases and will be welcome. But random changes of brick colour over a single facade should be avoided.

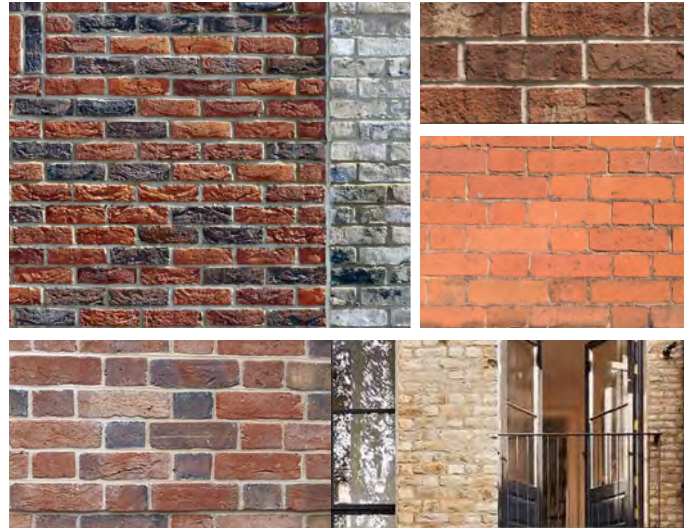

Fig.468 Palette of brick colours and textures

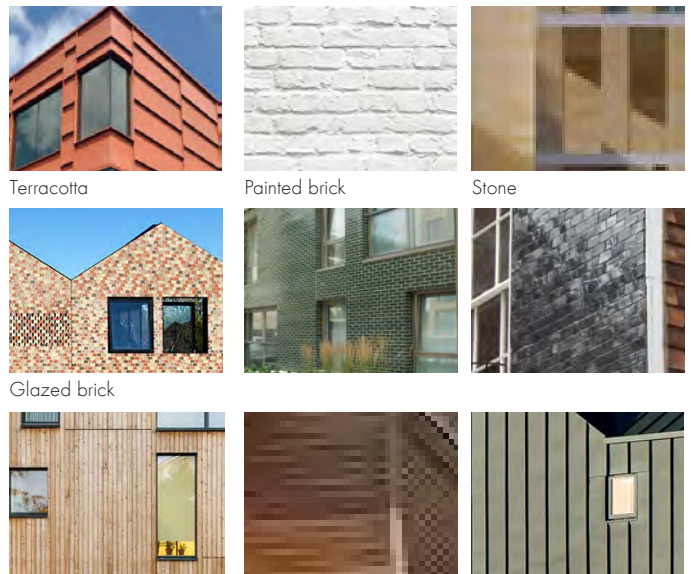

Fig.469 Palette of textural materials other than brick

### 7.3.15 Courtyard facade material

The facades of inner courtyards in York Yard South offer opportunities for discovering contrasts, and contributing to that sense of coming across a hidden delight in York.

The walling material of the inner courtyards may differ from the main brick walling material of the street frontages.

The facade material for the inner courtyards may offer a colour or tonal contrast to the material used on street frontages, to intensify the sense of different, more private enclaves within these courtyards.



Fig.471 Courtyard in Paris with highly articulated courtyard facade ✓



Fig.472 Inner courtyard in Berlin, a green oasis and play space ✓

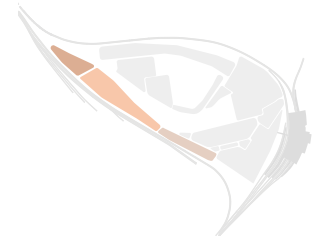

Fig.470 Inner courtyard panelled material ✓



Fig.473 Inner courtyard timber material contrasts with brick street frontages ✓





**7.3.16 Windows and doors**

Refer to Chapter 06 Appearance Site Wide. The following guides apply in addition:

**Mansion blocks shall include bay windows and oriel windows**

Mansion blocks may include windows of a horizontal proportion as a variation to the predominant pattern, but limited in number so as to maintain the overall vertical order of the facade

Mansion blocks should vary the window size or detail (cill height and head height) in one or more elevational bays to suggest variation in internal floor levels.

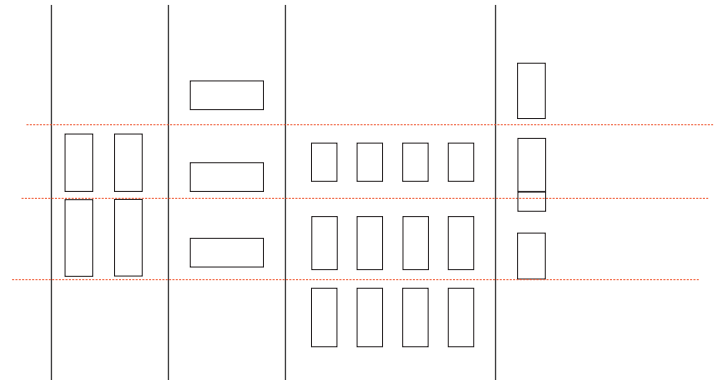

**Fig.474** Diagram of windows with irregular cill and head heights

**7.3.17 Entrances**

**Mansion blocks**

**Entrances to mansion blocks shall allow open passages and views into the inner mansion block courtyards.** This is to create in York Central the sense of permeability and “snickets” that is so particular to York.

Passages shall be gated to allow closing off for security at night.

**Entrance lobbies shall open off these passages. Entrance lobbies shall be highly glazed and shall feel open and light. Passages shall have robust but high quality finishes suitable for a semi-public route.**



**Fig.475** Precedent of open archways in New Earswick

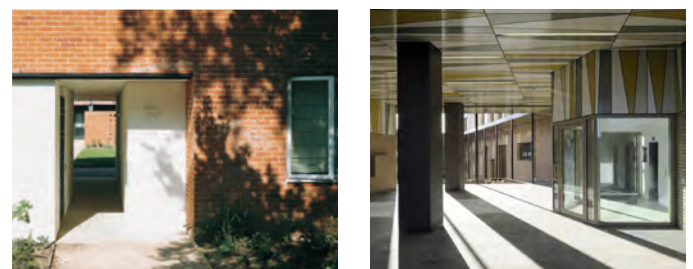

**Fig.476** Examples of open passageways and entrances

---

### 7.3.18 Foreground buildings

Refer also to Chapter 06 Appearance Site Wide.

*Foreground* commercial buildings in this Character Area occupy prominent positions in York Central and will be the focus of longer views on the site.

M(west) will be the gateway to the new park. It is stop-end to the Mansion block frontage along Central Park looking towards the Millennium Green and positioned on the turning to Foundry Village. It should offer an open, welcoming frontage to York Central to both these aspects.

M(east) looks onto one of the triangular squares in Station Quarter. The frontage should be solid and urban, contributing to the enclosure of the public space.



**Fig.477** Locations for "Foreground" buildings in York Yard South

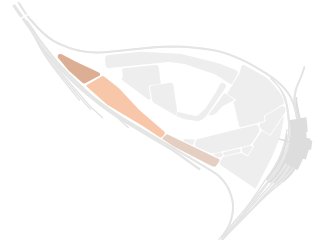

Fig.478 Housing, Vauban, Germany



Fig.480 Apartment building, New York USA



Fig.479 Apartment building, Paris

Examples of a foreground building 'type' in York Yard Gateway



Fig.481 Apartment building Mahallat, Iran

Examples of a foreground building 'type' in York Yard Rise

## 7.4 FOUNDRY QUARTER

### 7.4.1 Life in Foundry Quarter

The Foundry Quarter is envisaged as a family of liveable streets and varying building typologies centred around a number of community focused, public, open spaces, play streets and recreation spaces. The area should provide a broad mix of housing including terraced housing, mews housing, maisonettes, mansion blocks and workspace, with an amount of supportive retail based around the Foundry Pub and Foundry Yard.

The Foundry Quarter should be characterised by the community areas that it encloses - the Foundry Village; Village Square; Leeman Yard; and the Foundry Yard. It will also be characterised by its relationship with Central Park; the Stream Garden; and the existing communities and streets that it borders. The streets should be permeable, with pedestrian movement possible through and between blocks and courtyards and where possible connect with the network of public open spaces.



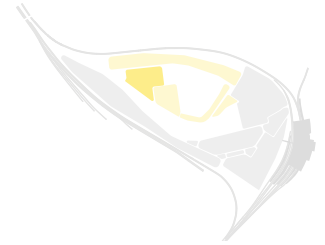

### 7.4.2 Character

Buildings in the Foundry Village will take their cue from the industrial heritage in this area of the site – the existing foundry buildings, a red brick 1930s administration building on Leeman Road, and the railway worker terraces on Carlisle and Carleton Streets. Predominantly brick, with a range of reddish and grey tones, the new buildings shall continue in a contemporary manner the scale and the robust, plain detailing of the heritage buildings.

The new building types in this area are housing terraces, mews and apartment blocks. The existing buildings within the site boundary are the Albion Iron Foundry shop, the engine shed, the Smith's shop and office, and a small red brick 1930s administrative building.



Fig.482 Albion Foundry building



Fig.483 Smith's shop office



Fig.484 Railway worker housing on Carleton Street



Fig.485 1930s building

### 7.4.3 Grain

Substantially composed of terraces of individual residential plots – either houses or mews - the Foundry Quarter will have much in common in its urban grain with the nearby Victorian terraced streets which are a natural precedent for this character area. The Foundry Village streets shall sit parallel to Carlisle and Carleton Streets. The new streets shall continue the rhythm and grain of the Victorian terraces.

Mansion blocks within the Foundry Quarter shall continue this regular, residential grain in the rhythm of their street frontages, the scale of entrances, and the pattern of individual apartment ground floor gardens. Grain in the Foundry Quarter shall arise from -

**Streets parallel to existing railway terraced housing streets**

**Regular terraced house grain**

**Individual domestic plots expressed in frontages and gardens**



Fig.486 Grain - Foundry Quarter

#### 7.4.4 “Uniform irregularity”

The degree of irregularity varies between the more regular housing terraces and the modelled mansion blocks.

Each terrace of houses will be predominantly regular in form, but the design will vary from terrace to terrace. While following a similar terraced house pattern, terraces shall offer variations on a theme, so that streets shall have their own subtly distinct character.

The Mansion Blocks shall be modelled with a greater degree of irregularity.

The combination of all shall contribute to the overall “uniform irregularity” of the Foundry Quarter.

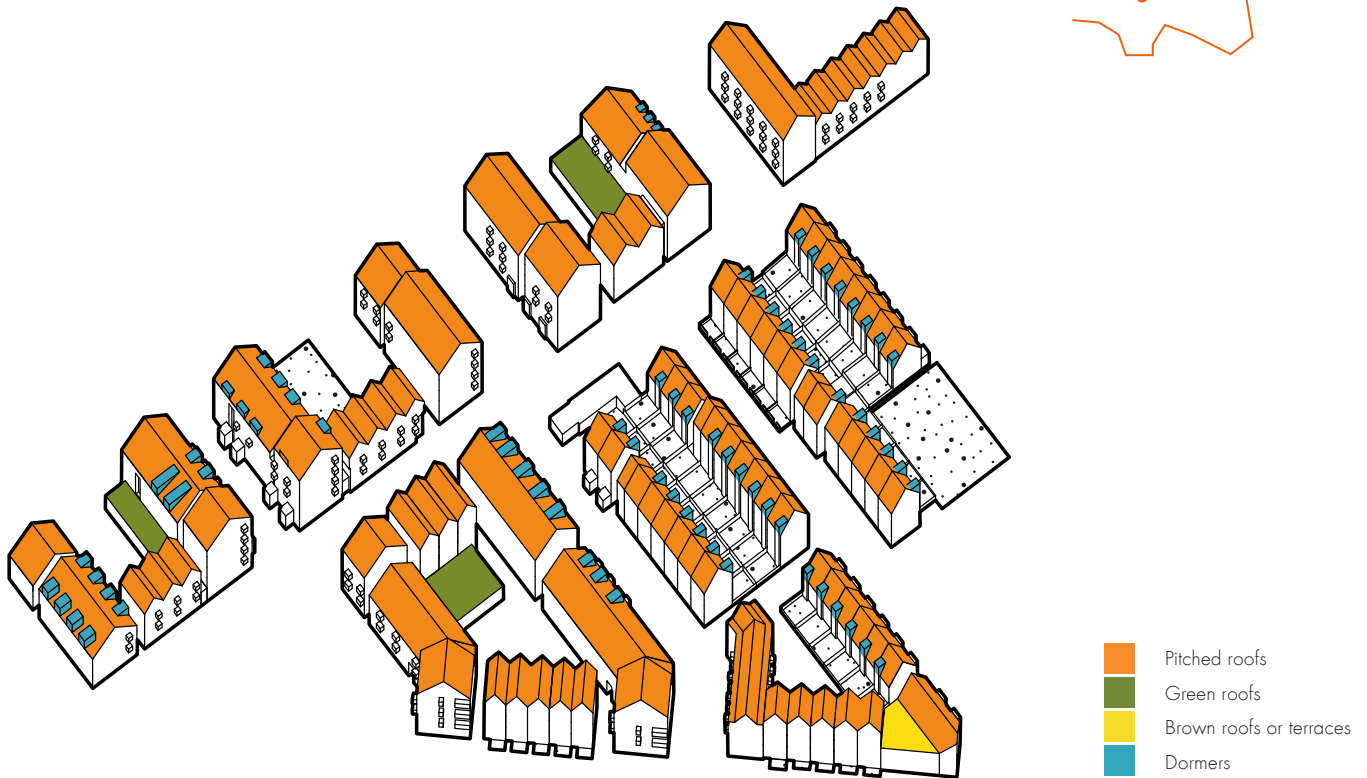
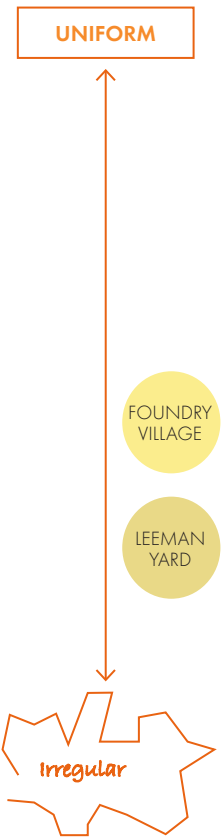
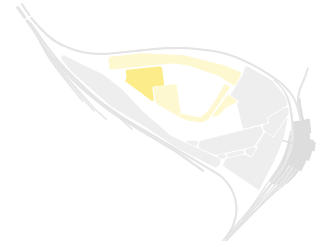

Fig.487 Predominantly pitched roofs - zoom in on Foundry Village (example from the Illustrative Scheme)



#### 7.4.5 Roofs

Pitched roofs shall be the predominant roof form.

The roofline and skyline of the Housing Terraces and Mews shall offer a mainly regular, repeated roof pattern which expresses the plot sizes.

The roof form and roof line on the apartment buildings shall follow a pitched form similar to the Housing Terraces and Mews.

Long roofs shall be broken down in scale using multiple pitches, stepped levels and dormers.

Chimneys and dormers may add to the silhouette.

#### 7.4.6 Roof materials

See Chapter 06 Appearance Site Wide.

#### 7.4.7 Gutters and downpipes

The preference is for concealed gutters and downpipes on primary frontages.

Any exposed gutters and downpipes shall be integrated with the facade design..

As far as possible, exposed downpipes shall be positioned on side and rear elevations of mansion blocks rather than primary frontages.

**Any visible gutters and downpipes shall be metal (UPVC will not be acceptable).**

#### 7.4.8 Eaves, parapets, gables and verges

Parapets, projecting eaves and verges, simple eaves and plain mortar bedded verges, are all permissible in the Foundry Quarter.

**There shall be no thick box eaves or verges on any building.**

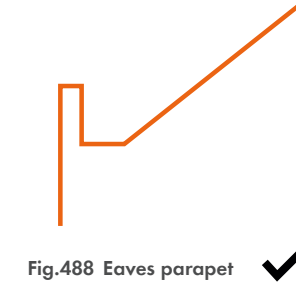

Fig.488 Eaves parapet ✓

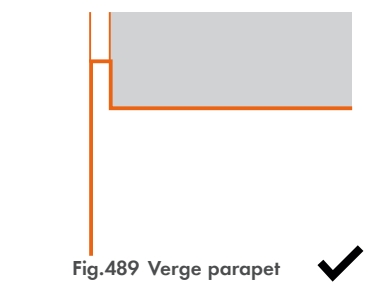

Fig.489 Verge parapet ✓

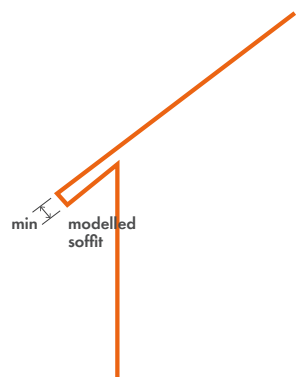

Fig.490 Projecting modelled eaves ✓

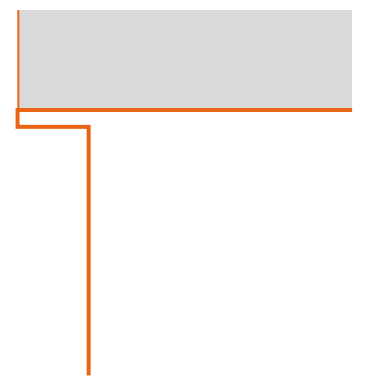

Fig.491 Projecting verge ✓

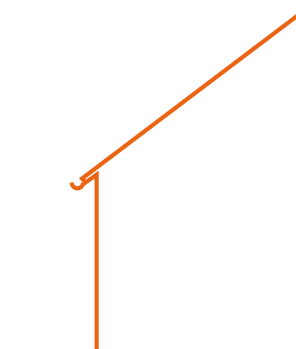

Fig.492 Simple eaves (inner courtyards only) ✓

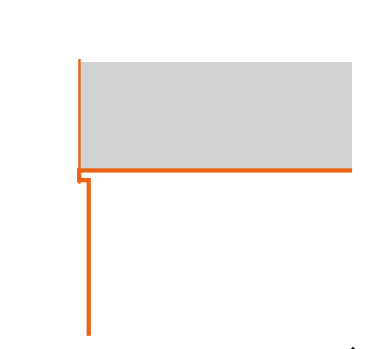

Fig.493 Plain mortar bedded verge ✓

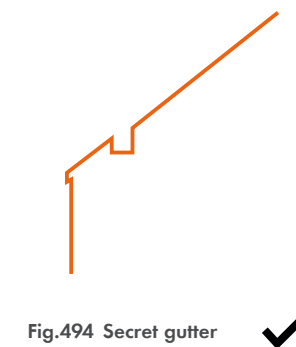

Fig.494 Secret gutter ✓

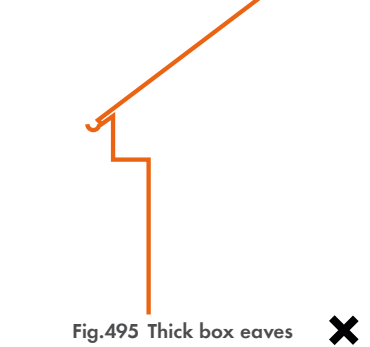

Fig.495 Thick box eaves ✗

### 7.4.9 Facade composition

The Foundry Village will contain mews and housing terraces of two, three and four storeys. Generally, the higher the terrace, the richer and more modelled the facade should be.

**Streets shall generally include groups or terraces of between four and eight houses, or repeated pairs. The regular repeated pattern of the house or mews street frontage will be a key feature of the Foundry Quarter streets.**

**There shall nevertheless be variation in this pattern between the different streets so that streets differ in character.**

**Refer to Chapter 06 Appearance Site Wide for guidance on the arrangement and proportion of window and door openings.**

The mansion blocks within Foundry Village shall be articulated in a similar fashion to the larger terraces with a repeated facade pattern and high degree of modelling.

The mansion blocks in Leeman Yard shall follow the guidelines for mansion blocks written for York Yard South in section 7.3 above.

The use of bay windows is encouraged.

**Any balconies shall generally be shallow or Juliette balconies. Projecting balconies will not be acceptable on mews, terraces or townhouses.**



Fig.496 Example of housing type, Woodside Square, London



Fig.497 Example of housing type, Accordia, Cambridge



Fig.498 Example of housing type, Thurrock, Essex





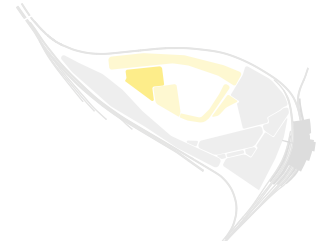

#### 7.4.10 Facade material

Walls in the Foundry Quarter shall be predominantly brick using the York Central palette. Painted brick may also be used. Brick or painted brick shall constitute 75% of the walling material in Foundry Quarter.

Painted brick shall use a colour or tone which blends with the palette of brick used across York Central, to give subtle contrast.



Fig.499 Palette of brick colours and textures, including painted brick



Timber

Metal

Fig.500 Palette of example 'textural' materials which may be used in conjunction with brick

---

#### 7.4.11 Balconies for housing terraces and mews

Refer to Chapter 06 Appearance Site Wide for guidance on design of balconies generally within York Central.

**Balcony types shall be used to help delineate the elevation bays, emphasising the vertical bay divisions rather than horizontality of frontage.**

The smaller housing terraces and mews shall use shallow, or Juliette balconies, rather than deep projection balconies.

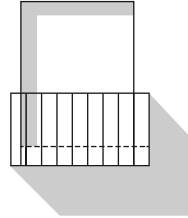

Fig.503 Projecting balcony ❌

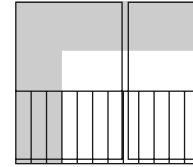

Fig.501 Recessed balcony ❌

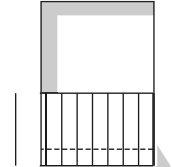
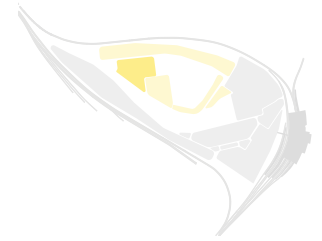

Fig.502 Juliette balcony ✓



### 7.4.12 Balconies for mansion blocks

Refer to Chapter 06 Appearance Site Wide for guidance on design of balconies generally within York Central.

**A combination of different balcony types shall be used to give “uniform irregularity” to the frontages to the park, streets and courtyards.**

**Balcony types shall be used to help delineate the elevation bays, emphasising the vertical bay divisions rather than horizontality of frontage.**

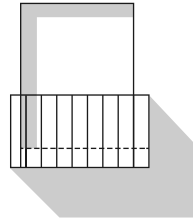

Fig.508 Projecting balcony ✓

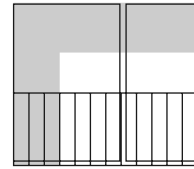

Fig.506 Recessed balcony ✓

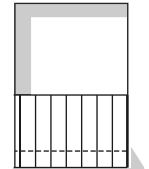

Fig.507 Juliette balcony ✓

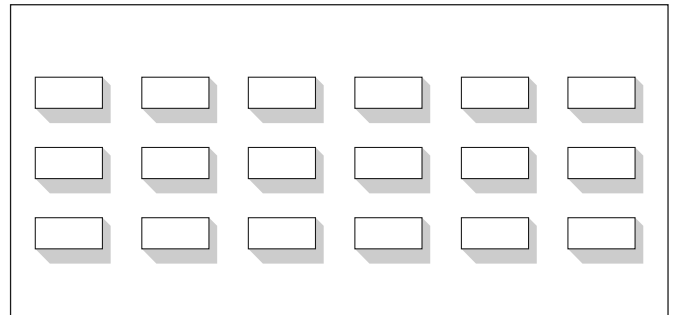

Fig.505 Monotonous regular balcony arrangement ✗

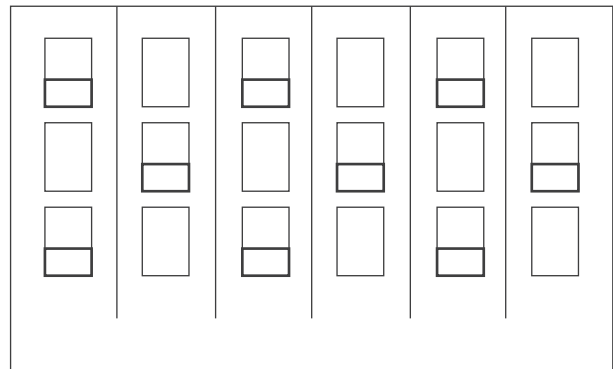
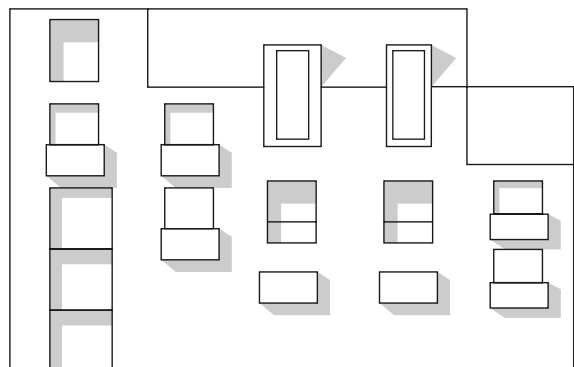

Fig.504 Monotonous regular balcony arrangement ✗



Example of arrangement with Uniform Irregularity ✓

---

### 7.4.13 Foreground buildings

Refer also to Chapter 06 Appearance Site Wide.

A new building in new Foundry Yard may be a *Foreground* building in this Character Area, but only if the use of the new building is for community or workspace.

**A foreground community building in this Character Area may be “artistic-industrial” in their appearance.**

If use of the building in this position is residential, the building shall be integrated as part of the brick background buildings in this Character Area.



Fig.509 Locations for “Foreground” buildings in Foundry Quarter

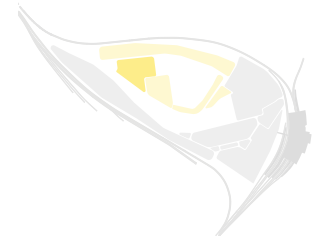

Fig.510 Stadshal (City Hall) Ghent, Belgium



Fig.513 Peoples' Pavilion, Eindhoven



Fig.511 Pensthorpe Playbarn, Norfolk



Fig.514 Lycée Hôtelier de Lille



Fig.512 Howe Green House School, Hertfordshire



Fig.515 Cabin, Geilo, Norway



Examples of buildings which would be considered a foreground community building in Foundry Quarter



## 8 BUILDING TYPOLOGIES

This section outlines the types of buildings that would be appropriate within the York Central site. It includes guidance and discussion on building access, functionality, amenity space and aspects of placemaking and architectural language that are intended to help to characterise the site.

## 8.1 INTRODUCTION

To ensure a rich and varied urban grain a range of different building typologies shall be used across the York Central site. The combination of building typologies and streets will help to define each of the Character Areas around the site and contribute to a sense of place and community.

The following pages provide the guidelines for building typologies. Many building typologies occur in more than one Character Area. The *function* of a building type and aspects related to its *use* are covered in this chapter. The building's *appearance* will however change depending on the character area, and for this the reader should refer to Chapter 07 Appearance by Character Area.

Please refer to Parameter Plans 008 and 009 and York Central Development Specification for full quantities and mix of uses.

No guidance is provided for 'meanwhile uses'. This shall be at the discretion of the CYC and YCP.

All residential buildings shall be built to basic minimum standards included in the 'London Housing Design Guide SPG' .

Principles of Crime Prevention Through Environmental Design (CPTED) should be considered for all building typologies.

### 8.1.1 Museum Quarter

At the centre of the Museum Quarter is the National Railway Museum. The National Railway Museum are creating the brief for the extension and redevelopment of their buildings and which will be fully integrated with the masterplan for York Central.

### 8.1.2 Station Quarter

The Station Quarter will become a new high quality urban district for York that is set around the historic and significant National Railway Museum and station.

Adjacent to the mainline railway station, this will be the arrival space for visitors to York and to York Central and form a new destination for businesses, for tourists and for local residents alike.

The Station Quarter will be defined by its public space and range of high quality commercial spaces,

offices, homes, retail, cafés/restaurants, hotels and leisure facilities. Multi storey car parking and small scale pavilions are also anticipated. This mix of uses will create a vibrant new destination for the city which will be active throughout the day and into the evening.

A range of different building typologies can be used See "Fig.01 Diagram showing the possible typologies in each character area".

### 8.1.3 York Yard South

York Yard south is a predominantly residential area and should comprise a mix of courtyard or linear mansion blocks and individual house types to provide a range of homes. The area bounds the southern edge of Central Park and will benefit from views across into the green space and Foundry Village beyond.

A range of different building typologies can be used. See "Fig.01 Diagram showing the possible typologies in each character area".

**York Yard South shall not include any office building typologies, multi storey car parks, or hotels.**

### 8.1.4 Foundry Quarter

The Foundry Quarter is envisaged as a family of different building typologies centred around a number of community focused, public, open spaces, play streets and recreation spaces. The area should provide a broad mix of housing including terraced housing, mews housing, maisonettes, mansion blocks and linear apartment buildings. There is an opportunity to place supportive retail around Foundry Square and community uses/workspace at the Foundry Yard.

A range of different building typologies can be used according to the different areas within the Foundry Quarter. See "Fig.01 Diagram showing the possible typologies in each character area".

**The Foundry Quarter shall not include any office building typologies, multi storey car parks, or hotels.**



### 8.1.5 Building Typologies by Character Areas

This diagram lists the typologies for each Character Area, and refers the reader to where information on each typology can be found in this document.

#### YORK YARD SOUTH

- **York Yard South**  
 "5.2 Mews"  
 "5.3 Terraces"  
 "5.4 Town Houses"  
 "5.5 Mansion Blocks"

#### FOUNDRY QUARTER

- **Foundry Village**  
 "5.2 Mews"  
 "5.3 Terraces"  
 "5.4 Town Houses"  
 "5.5 Mansion Blocks"

#### STATION QUARTER

- **Cinder Yards**  
 "5.7 Office Buildings"  
 "5.8 Mixed-use Buildings"  
 "5.10 Hotel Buildings"  
 "5.5 Mansion Blocks"  
 "5.6 Workspace"

#### CENTRAL PARK

- **Central Park**  
 "5.9 Pavilion Buildings"

- **Foundry Terrace**  
 "5.3 Terraces"  
 "5.4 Town Houses"  
 "5.5 Mansion Blocks"

- **New Square**  
 "5.9 Pavilion Buildings"

- **Leeman Yard**  
 "5.2 Mews"  
 "5.3 Terraces"  
 "5.4 Town Houses"  
 "5.5 Mansion Blocks"

- **George Square**  
 "5.9 Pavilion Buildings"

- **Foundry Yard**  
 "5.2 Mews"  
 "5.3 Terraces"  
 "5.4 Town Houses"  
 "5.5 Mansion Blocks"  
 "5.6 Workspace"

- **Station District**  
 "5.7 Office Buildings"  
 "5.8 Mixed-use Buildings"  
 "5.10 Hotel Buildings"  
 "5.5 Mansion Blocks"

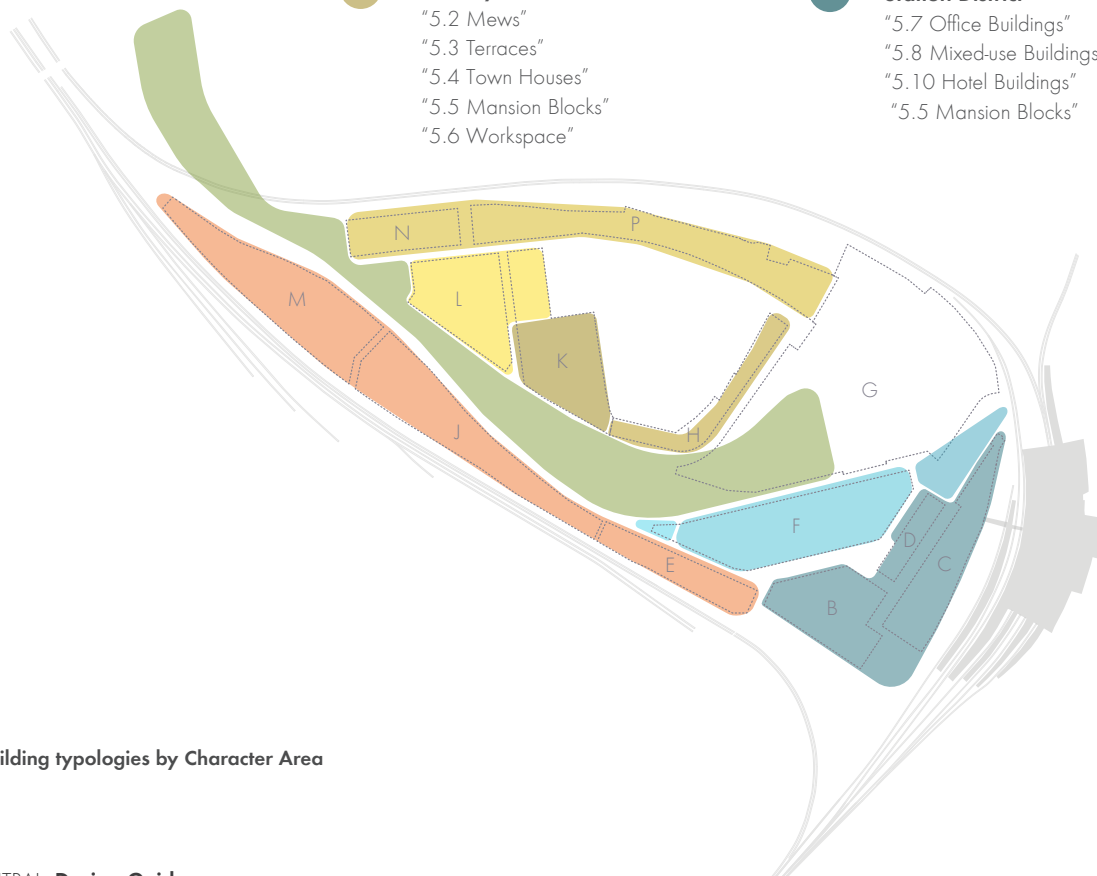

Fig.516 Building typologies by Character Area

## 8.2 MEWS

These houses are intended to be humble in scale with a **maximum of 3 storeys where the uppermost storey is inhabited roof space.**

The mews houses are intended to work with 'liveable streets' (mews street types, play streets or pedestrian courtyard blocks) where the street itself becomes an extension of the homestead. In this condition it is permissible to provide a doorway straight onto the street, without defensible space.

**Private amenity space shall be provided at street level at the rear of the property, or on active rooftops, roof terraces or by a combination of these. Projecting balconies shall not be permitted.**

**Residential ceiling heights shall be a minimum of 2.5m.**

**Car parking will be provided for residents at a rate of up to 1 space per house. Parking areas shall be designed to be small and subdivided with soft landscaping and trees. Consideration shall be given to the visual aspect between the parking area and any public space or residential dwelling.** Refer to Building for Life 12 standard or current best practice guidance.

**Where parking is provided on plot, provision shall be made for electric vehicle charging. Fast charge points for electric vehicle charging shall be provided in the carparks.**

**External enclosed refuse storage shall be provided.**

Grey water harvesting should be incorporated into the building services design if practicable.

**Cycle stores shall be provided for each home and should comply with relevant current guidance.**

**Rainwater harvesting shall be incorporated into the building services design.**

**Low flow water fixtures and fittings shall be specified. External drying space shall be provided.**

The inclusion of internal drying spaces appropriate to the expected number of occupants is strongly encouraged.

Principles of CPTED should be considered throughout. **Where a gable end faces onto public realm there must be a planted buffer zone of at least 1m. Railings or fences shall not be permitted. Gable ends must include a window in the elevation.**

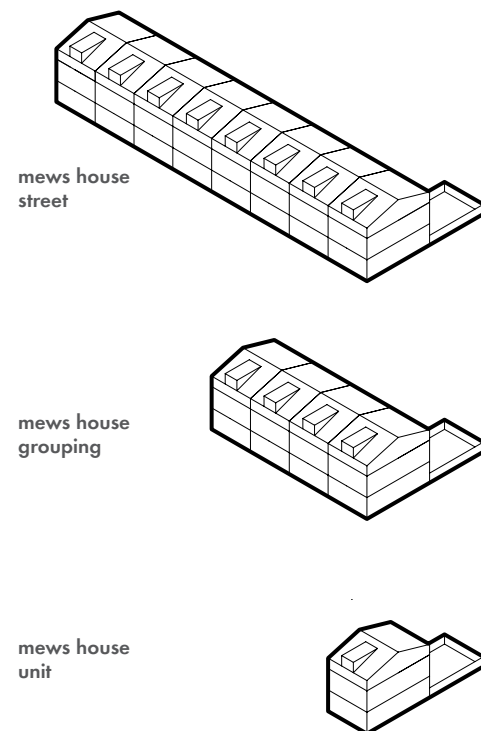

Fig.517 Diagram to illustrate a mews house as a single unit, repeated to form a group or street terrace



Fig.518 Accordia, Cambridge



Fig.519 Harvard Gardens, London



Fig.520 Bartle Garth, York



Fig.521 Chapter House Street, York

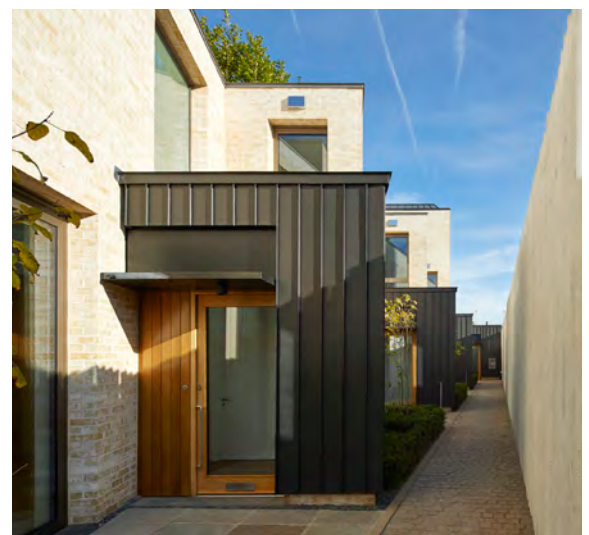

Fig.522 Paradise Gardens, London



Fig.523 Anne Mews, London

Examples of contemporary mews housing illustrating the intimate spaces created by small-scale mews buildings opening onto quiet streets. The design of front doors, porches and little front gardens contribute to the quality of the mews streets.

## 8.3 TERRACES

Residential floor to ceiling heights shall be a minimum of 2.5m. Housing terraces may differ in storey heights between 2-4 storeys and comprise either individual houses or stacked maisonettes.

Amenity space shall be provided at street level, via roof terraces, Juliette balconies, recessed or semi projecting balconies. Projecting balconies shall not be permitted.

Car parking will be provided for residents at a rate of up to 1 space per house. Parking may be provided on plot (integrated within the ground floor of the building), on street, or within dedicated residential parking areas. Where parking is provided on plot, provision shall be made for electric vehicle charging. Parking areas shall be designed to be small and subdivided with soft landscaping and trees. Consideration shall be given to the visual aspect between the parking area and any public space or residential dwelling. Parking must be overlooked by residents. Refer to Building for Life 12 standard or current best practice guidance.

Fast charge points for electric vehicle charging shall be provided in the carparks.

External enclosed refuse storage shall be provided on plot at street level.

Grey water harvesting should be incorporated into the building services design wherever practicable.

Rainwater harvesting shall be incorporated into the building services design. Low flow water fixtures and fittings shall be specified.

Where a terraced house comprises a stacked maisonette either a communal or individual bin store shall be provided on plot at street level.

Cycle stores shall be provided for each home and should comply with relevant current guidance.

Pedestrian permeability through between terraces shall be provided at a maximum

distance of 60m or every 8 plots (whichever is lesser) these are intended to provide access to back gardens and allow pedestrian permeability in and around terraced streets See 'pedestrian connectivity'.

External drying space shall be provided. The inclusion of internal drying spaces appropriate to the expected number of occupants is strongly encouraged.

Where a gable end faces onto public realm there must be a planted buffer zone of at least 1m. Railings or fences shall not be permitted. Gable ends must include a window in the elevation.

The York terrace typology shall be scrutinised to establish appropriate spacing for 'ginnels' or cut throughs between blocks.

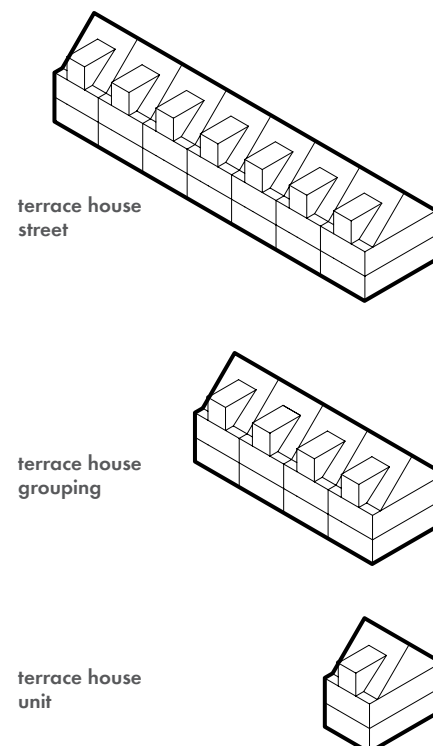

Fig.524 Diagram to illustrate a terrace house as a single unit, repeated to form a group or street terrace



Fig.525 Wakefield Street townhouses, London



Fig.526 Derwenthorpe, York



Fig.527 Northumberland Street, Liverpool



Fig.528 Woodside Square, London



Fig.529 Dujardin Mews, London



Fig.530 Newhall, Essex

Examples of terraces of houses showing the rhythm of repeated forms, and examples of both pitched and small scale flat roofs

## 8.4 TOWN HOUSES

Residential floor to ceiling heights shall be a minimum of 2.5m. Townhouses must be a minimum of 3 storeys and comprise either individual houses or stacked maisonettes.

Amenity space must be provided at street level, or via roof terraces, Juliette balconies or semi projecting balconies. Recessed or projecting balconies shall not be permitted.

Car parking will be provided for residents at a rate of up to 1 space per house. Parking may be provided on plot (integrated within the ground floor of the building), on street, or within dedicated residential parking areas. Parking areas shall be designed to be small and subdivided with soft landscaping and trees. Parking must be overlooked by residents. Refer to Building for Life 12 standard or current best practice guidance.

Consideration shall be given to the visual aspect between the parking area and any public space or residential dwelling. Where parking is provided on plot, provision shall be made for electric vehicle charging. Fast charge points for electric vehicle charging shall be provided in the carparks.

Enclosed external refuse storage shall be provided on plot for each individual property.

Grey water harvesting should be incorporated into the building services design wherever practicable.

Rainwater harvesting shall be incorporated into the building services design. Low flow water fixtures and fittings shall be specified.

Where a townhouse comprises a stacked maisonette either a communal or individual bin store shall be provided on plot at street level. Bin stores should be designed within the footprint of the building.

Cycle stores shall be provided for each home and should comply with relevant current guidance.

Pedestrian permeability between townhouses shall be provided at a maximum distance of 60m or every 8 plots (whichever is lesser).

These are intended to provide access to back gardens and allow pedestrian permeability in and around terraced streets. See 'pedestrian connectivity'. The York Terrace typology shall be scrutinised to establish appropriate spacing for 'ginnels' or cut throughs between blocks.

Parking areas shall be designed to be small and subdivided with soft landscaping and trees. Consideration shall be given to the visual aspect between the parking area and any public space or residential dwelling.

External drying space shall be provided. The inclusion of internal drying spaces appropriate to the expected number of occupants is strongly encouraged.

Where a gable end faces onto public realm there must be a planted buffer zone of at least 1m. Railings or fences shall not be permitted. Gable ends must include a window in the elevation.

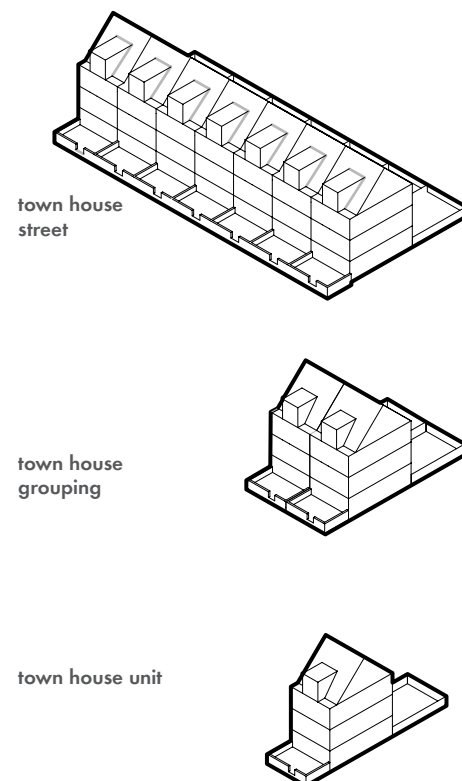

Fig.531 Diagram to illustrate a town house as a single unit, repeated to form a group or street terrace



Fig.532 Townhouses. Salford



Fig.534 Leamouth Street, London



Fig.533 Signal townhouses, Greenwich



Fig.535 The Mount, York

Examples of townhouse

## 8.5 MANSION BLOCKS

There are a range of opportunities to provide housing in mansion blocks across the York Central site. They are envisaged as robust blocks, intended to create a formal and comprehensive edge to a landscape or street. **They must form a comprehensive whole and have a definable public facing 'front' and private or semi private 'back.'**

**Minimum residential floor to ceiling 2.5m. Where allowing for ground floor retail units ground level floor to floor heights should be a minimum 4.0m.**

### 8.5.1 Accessible design

Where appropriate mansion blocks should provide an appropriately sized area for the secure storage of wheelchairs and mobility assistance devices.

### 8.5.2 Refuse

**Enclosed external refuse storage shall be provided at street level.**

### 8.5.3 Access

**Access shall be provided from street level via a lobby entrance. Lobbies should be designed as active frontages with a direct relationship with the adjacent public realm.**

**Entrances to mansion blocks shall allow open passages and views into the inner mansion block courtyards.** This is to create the sense of permeability.

**Where mansion blocks are combined to form courtyard housing, access and cut throughs must be provided.** These are intended as contemporary 'snickets' and will contribute to the Pedestrian Connectivity across the site. See Chapter 04 Pedestrian Connectivity. **Entrance lobbies shall open off these passages and shall feel open and light.** This creates vibrant frontages and will help animate the public realm and enhance natural surveillance. **There should be level access from the street into building lobbies.**

### 8.5.4 Servicing

**Communal refuse stores shall be provided for use of all residents. Residents at street level may be provided separate individual refuse stores where appropriate. Refuse quantum and locations in relation to servicing routes**

**should comply with relevant current guidance.**

**Communal external drying space shall be provided.** The inclusion of internal communal/private drying spaces is strongly encouraged.

Grey water harvesting and rainwater harvesting should be incorporated into the building services design wherever practicable. **Low flow water fixtures and fittings shall be specified.**

### 8.5.5 Cycle storage

**Cycle stores shall be provided for each home and should comply with relevant current guidance.**

### 8.5.6 Car parking

**Car parking will be provided for residents at a rate of up to 0.45 spaces per dwelling unit. Parking may be provided through a combination of podium parking, on street parking, on plot parking and private residents parking areas. Car Parks shall include electric vehicle fast charging points. Parking shall be security controlled or must be overlooked by residents.** Refer to Building for Life 12 standards.

### 8.5.7 Amenity space

**Communal external amenity space must be provided at ground level. Where possible, amenity space should also be provided at upper floors by the use of building setbacks and terraces/roof gardens.**

**Private amenity space shall be provided as private gardens for ground/podium level units. On upper levels private amenity shall be provided via recessed/semi recessed/projecting balconies, or inset roof terraces.**

**Where possible, rooftops shall be active and provide communal facilities and amenity space.**





Fig.536 Brentford, London



Fig.538 Little Kelham Sheffield

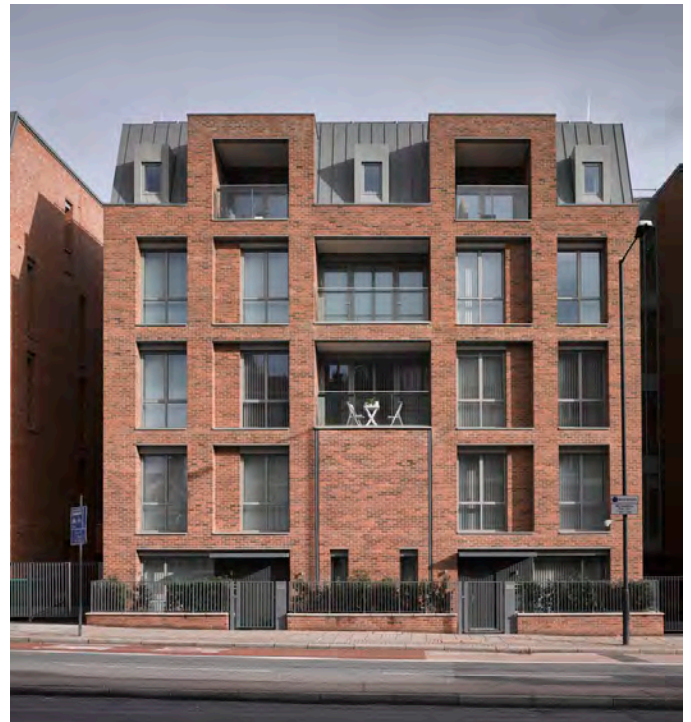

Fig.539 Kidderpore Avenue, London



Fig.537 St John's Hill, London

Examples of modern mansion blocks and mixed housing blocks



Fig.540 Tapestry Building, London

## 8.6 WORKSPACE

---

There is an opportunity within the Foundry Yard to provide flexible workspace on the site. This might include communal workspace, space for start ups, creative businesses, artists studios or live/work units.

**These buildings should be designed to allow flexibility and for a changing mix of uses over time.**

**Workspace buildings should provide a minimum floor ceiling height should be a minimum of 2.8m.**

Taller floor to ceiling heights or open/exposed roof structures are encouraged.

### 8.6.1 Family friendly

Child care facilities and crèches are strongly encouraged as part of the design and provision of workspace facilities. This should include the provision of a secure area to store buggies/prams.

### 8.6.2 Access

**Access shall be provided from street level via a lobby entrance. Lobbies should be designed as active frontages with a direct relationship with the adjacent public realm. Appropriate materials should be used to maximise transparency at the base of buildings.**

This creates vibrant frontages and will help animate the public realm and enhance natural surveillance.

### 8.6.3 Amenity space

External communal amenity space should be provided at ground/podium level. **Where possible, opportunities should be taken to provide amenity space at upper floor levels by the use of building setbacks and terraces/roof gardens.**

This will provide unique outdoor spaces for shared use by building users. **Large recessed balconies may be permitted where they are integrated within the overall design of the building. Semi recessed or projecting balconies shall not be permitted. There should be level access from the street into building lobbies.**

### 8.6.4 Servicing

Servicing provision and access for workspace buildings must be cognisant of the various uses and of the possible requirements of the buildings users.

**Service spaces and access must be flexibly designed. Servicing areas shall be cognisant of their visual aspect from adjacent buildings and local context.**

Grey water harvesting and rainwater harvesting should be incorporated into the building services design wherever practicable.

**Low flow water fixtures and fittings shall be specified.**

### 8.6.5 Cycle storage

**Cycle stores shall be provided and should comply with relevant current guidance.**

### 8.6.6 Refuse

**Enclosed refuse storage shall be provided at street level. This shall include recycling facilities.**



Fig.542 Albert Works, Sheffield



Fig.544 Albert Works, Sheffield



Fig.543 Toffee Factory, Newcastle

Examples of industrial buildings converted to modern workspaces



Fig.545 Metropolitan Wharf, London

## 8.7 OFFICE BUILDINGS

---

Office buildings will play a key role in defining the Station Quarter. They will offer flexible floor plates to larger tenants or be subdivided into areas for smaller tenants. There are likely to be retail elements at the ground floor levels with office activities located on floors above.

**Floor to ceiling heights should be a minimum of 2.8m**

**Ground floor to floor heights should be a minimum 5m** this is both to allow for the inclusion of retail units, good day lighting, servicing and a sense of space at street level.

### 8.7.1 Access

**Access shall be provided from street level via a lobby entrance. Lobbies should be designed as active frontages with a direct relationship with the adjacent public realm.** This creates vibrant frontages and will help animate the public realm and enhance natural surveillance.

**There should be level access from the street into building lobbies.**

### 8.7.2 Amenity space

**Where possible, opportunities should be taken to provide amenity space at upper floor levels by the use of building setbacks and terraces/ roof gardens.** This will provide unique outdoor spaces for shared use by building staff.

**Large recessed balconies may be permitted where they are integrated within the overall design of the building. Semi recessed or projecting balconies shall not be permitted.**

### 8.7.3 Family friendly

Child care facilities and crèches are strongly encouraged to be included as part of the design and provision of office facilities. This should include the provision of a secure area to store buggies/prams.

### 8.7.4 Servicing

**Servicing access for office buildings shall be made through the backs of the buildings via access routes and dedicated service access doors.**

**The design of servicing areas shall be cognisant of their visual aspect from adjacent buildings and local context.**

**Where building servicing can only be achieved via the 'Cinder Yards', any servicing requirements will be fully integrated within the design of the building elevation and shall provide a positive aspect to the Cinder Yards.**

**Larger office buildings may require integral service/loading bays. These should be designed with closing doors and be as discreet as possible.**

Grey water harvesting and rainwater harvesting should be incorporated into the building services design wherever practicable.

**Low flow water fixtures and fittings shall be specified.**

### 8.7.5 Cycle storage

**Cycle stores shall be provided. Cycle quantities and security provisions for stores should comply with relevant current guidance.**

It is strongly encouraged that changing rooms and showers are incorporated into the design.

### 8.7.6 Refuse

**Enclosed refuse storage shall be provided at street level.**



Fig.546 St Pancras Square, Kings Cross, London



Fig.548 Newport Street, London



Fig.547 Brindley Place, Birmingham



Fig.550 St Pauls, Sheffield



Fig.549 Friargate, Coventry

## 8.8 MIXED-USE BUILDINGS

---

There are opportunities for mixed-use buildings on the York Central site within the Station Quarter and Foundry Yard.

**In mixed-use buildings floor to ceiling heights should be a minimum of 2.8m (commercial) and 2.5m (residential) floor to floor.**

**Ground floor to floor heights should be a minimum 6m** this is both to allow for the inclusion of retail units, good day lighting and a sense of space at street level.

### 8.8.1 Access

**Access shall be provided from street level via a lobby entrance. Lobbies should be designed as active frontages with a direct relationship with the adjacent public realm. Appropriate materials should be used to maximise transparency at the base of office buildings.**

This creates vibrant frontages and will help animate the public realm and enhance natural surveillance.

**There should be level access from the street into building lobbies.**

**Cores from any basement should be easily accessible and identified from below ground.**

### 8.8.2 Amenity Space

Where possible, opportunities should be taken to provide amenity space at upper floor levels by the use of building setbacks and terraces/roof gardens. This will provide unique outdoor spaces for shared use by building residents and staff.

### 8.8.3 Family Friendly

Child care facilities and crèches are strongly encouraged to be included as part of the design and provision of office facilities. This should include the provision of a secure area to store buggies/prams.

### 8.8.4 Servicing

Servicing access for mixed-use buildings shall be made through the backs of the buildings via access routes and dedicated service access doors. **The design of servicing areas shall be cognisant of their visual aspect from adjacent buildings and local context. Where building servicing can only be achieved via the 'Cinder Yards', any servicing requirements will be fully integrated within the design of the building elevation and shall provide a positive aspect to the Cinder Yards.** See Chapter 06 Appearance Site Wide for further detail.

Grey water harvesting and rainwater harvesting should be incorporated into the building services design wherever practicable.

**Low flow water fixtures and fittings shall be specified.**

### 8.8.5 Cycle Storage

**Secure communal cycle stores shall be provided at street level or lower ground floor level. Cycle quantities and security provisions for stores should comply with relevant current guidance.**

It is strongly encouraged that changing rooms and showers are incorporated into the design.

### 8.8.6 Refuse

**Enclosed refuse storage shall be provided at street level.**



Fig.551 Great Suffolk Street, London



Fig.553 Protein Studios, London



Fig.552 Primark, Newcastle  
Examples of mixed-use buildings

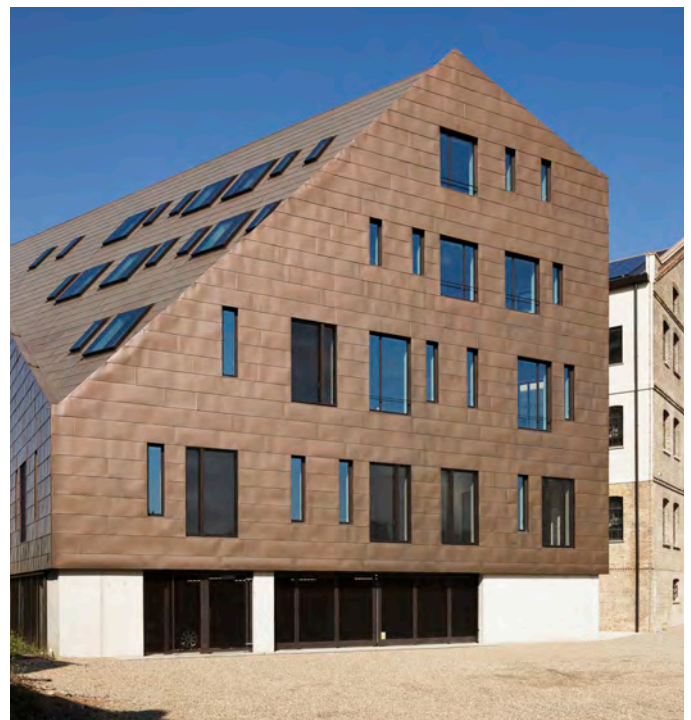

Fig.554 Gunpowder Mill. London

## 8.9 PAVILION BUILDINGS

There are opportunities on the site to create pavilion buildings – in New Square or George Square.

The pavilion buildings would contribute to the urban grain and place making and are intended to act as points of interest within the public realm and activate the public spaces in key locations.

**There should be pedestrian access around all sides of the pavilion at street level. Pavilion buildings should be designed with predominantly active frontages at street level. Appropriate materials should be used to maximise transparency and create vibrant frontages.**

**Pavilion buildings should be designed as flexible units with associated external amenity spaces which should spill out into the public realm that they sit within.**

Use and incorporation of recycled materials is strongly encouraged, this could include the relocation of existing buildings/railway infrastructure from within the site.

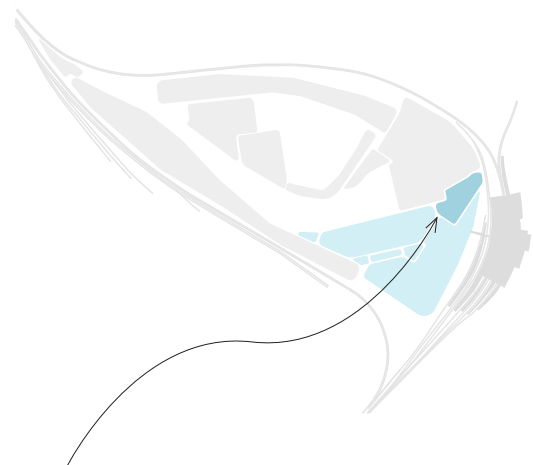
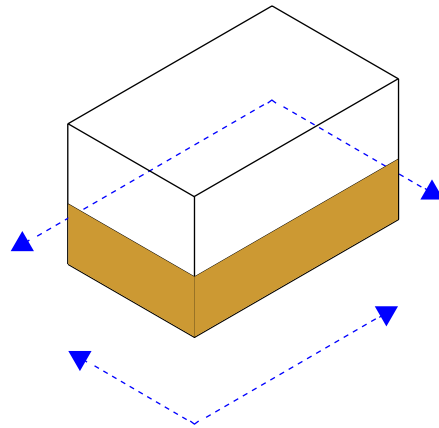

New Square: possible location for a pavilion

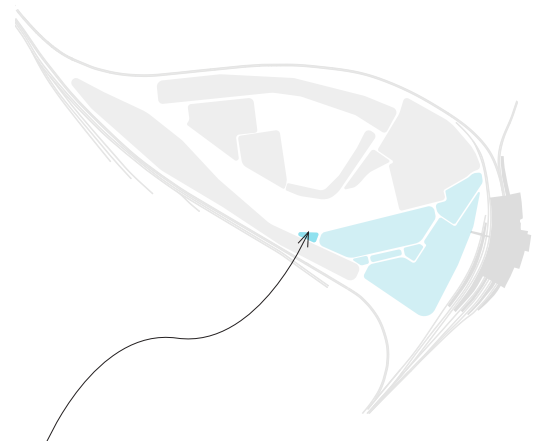

George Square: possible location for a pavilion





Fig.555 Dulwich Gallery pavilion, London



Fig.556 Information Centre, St Paul's, London



Fig.557 Regent's Place pavilion, London



Fig.558 Table Green Cafe, Battery Park, New York



Fig.559 Kiosk, Park am Gleisdreieck - Grün Berlin

Examples of pavilions in squares and parks

## 8.10 HOTEL BUILDINGS

There is potential in the York Central Masterplan to allow Hotel buildings within the Station Quarter.

**Floor to Floor heights should be a minimum of 3.1m**

**Ground floor to floor heights should be a minimum 6m** this is both to allow for the inclusion of retail units, good day lighting and a sense of space at street level.

### 8.10.1 Servicing

Servicing access for hotel buildings shall be made through the backs of the buildings via access routes and dedicated service access doors. **The design of servicing areas shall be cognisant of their visual aspect from adjacent buildings and local context. Where building servicing can only be achieved via the 'Cinder Yards', any servicing requirements will be fully integrated within the design of the building elevation and shall provide a positive aspect to the Cinder Yards.** See Chapter 06 Appearance Site Wide for further detail.

Grey water harvesting and rainwater harvesting should be incorporated into the building services design wherever practicable.

**Low flow water fixtures and fittings shall be specified.**

### 8.10.2 Access

**Access shall be provided from street level via a lobby entrance. Lobbies should be designed as active frontages with a direct relationship with the adjacent public realm. Appropriate materials should be used to maximise transparency at the base of hotel buildings.**

This creates vibrant frontages and will help animate the public realm and enhance natural surveillance.

**There should be level access from the street into hotel lobbies.**

**Cores from any basement should be easily accessible and identified from below ground.**

### 8.10.3 Refuse

**Enclosed refuse storage shall be provided at street level.**

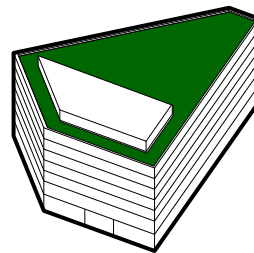

Fig.560 Opportunities for a public roof terrace on the hotel roof, overlooked by a rooftop pavilion

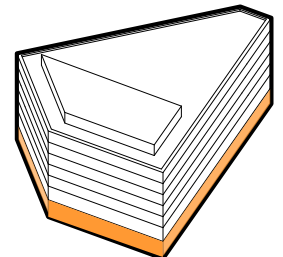

Fig.561 An active street frontage to the hotel



Fig.562 Apartment building, Riga, Latvia



Fig.564 'Patient Hotel', Copenhagen



Fig.563 Boutique Hotel, India



Fig.565 M89 Hotel, Milan

Examples of apartment and hotel buildings in the city

## 8.11 MULTI STOREY CAR PARK BUILDINGS

---

Car park buildings could be designed to ensure the possibility of future conversion to alternative uses e.g. housing or workspace. This must include consideration of appropriate floor to ceiling heights and building structure and the method of integrating access ramps into the structure.

Where possible the roofs of the buildings should be actively used and habited with activity for the local community.

**Lighting shall be designed to be cognisant of neighbouring homes and businesses and local ecology.**

A mix of uses is encouraged within the envelope of any multi storey car parks. **This must include active ground floor uses e.g. cycle hub/retail/workspace.** A programme of additional uses for the building is strongly encouraged for when the car park is not fully occupied e.g. exhibition space/outdoor sports (mini golf/boules/yoga/parcour)

**Car parks shall include dedicated blue badge parking.**

**Car parks shall have electric vehicle charging points, including fast charge points.**

The use of Photovoltaic Panels is encouraged where appropriate to the townscape setting.



Fig.566 Lincoln Road, Miami Beach open car park structure can be used for other activities



Fig.569 Park 'n' Play car park, Copenhagen



Fig.567 Car park used for orchestral performance, Peckham



Fig.570 Olympic car park, Stratford, London



Fig.568 Bussey building roof top cafe sculpture park, Peckham

Examples of car park buildings with interesting exteriors, and which accommodate other uses out of hours



Fig.571 Bussey building rooftop cafe, Peckham



## 9 SUSTAINABILITY

York Central will deliver a high-quality and sustainable new urban district, where city life meets beautiful landscape. Sustainability is integrated into the vision of York Central at all levels, from creating communities, homes and workplaces that positively contribute to the wider city of York, to public infrastructure and landscape. An integrated approach to sustainability should form part of every Reserved Matters Application and contribute to the creation of a sustainable new piece of the city.

## 9.1 SUSTAINABLE FRAMEWORK

### 9.1.1 Sustainability aims and aspirations

York Central aims to be an exemplary site.

The following guidelines set out the aims and aspirations for all future applications.

This section of the Design Guide should be read in conjunction with the York Central Sustainability Statement and Energy Statement.

These guidelines are intended as a framework to support forthcoming schemes and to provide the scope for sustainable measures that can be included in a scheme, and the issues that should be considered.

The sustainable aspirations for the York Central site can be broadly broken down into the following themes:

- Energy and carbon
- Health and wellbeing
- Water
- Materials and waste
- Transport
- Landscape and ecology
- Social and economic
- Climate adaptation

These topics are broad and apply to various stages of the design and construction process. Some or all of these topics will be relevant depending on the scale and nature of the Reserved Matters Application.

Sustainable measures around Landscape and ecology are included in Chapter 03 Public Open Space.

Refer to Chapter 04 for sustainability measures in connection with transport, including requirements for the design of streets which will encourage walking, cycling, shared streets, and the use of public transport.

Refer to Chapter 08: Building Typologies for guidance on requirements parking provision and

for cycle storage within various building typologies. Refer also to the Framework Travel Plan.

Guidance for water use is also provided within the Building Typologies chapter.

Measures for social and economic sustainability are addressed in the Planning Statement. Chapter 08 includes measures for pushchair storage rooms at ground floor in housing blocks.

**All Reserved Matters Applications will be expected to demonstrate how their application addresses the relevant sustainability aspirations. Applicants should make reference to York Central Sustainability Statement, and Energy Statement in addition to this Design Guide.**

### 9.1.2 Local Plan policy

As technology and the construction industry develops so to will the targets and measures of what makes an exemplary sustainable scheme.

**Any future reserved matters application must comply with CYC sustainability policies as a minimum and should aim to achieve the highest sustainable targets practicable at the time of the Reserved Matters Application.**

### 9.1.3 Sustainability and the National Railway Museum

As a very long-term steward of its site and part of the Science Museum Group, the National Railway Museum will explore opportunities through its design processes, to enhance the sustainability of its proposals. It will have regard to City of York Council's Local Plan Policy and work hard to put forward climate change resilient, and low-carbon design. A key part of any brief will be to ensure the health and well being of Museum visitors, volunteers and residents using the Museum's buildings and outdoor areas.

### 9.1.4 Community and custom self build

Opportunities for custom/community/self build may be considered where appropriate within the site.





Fig.573 Maximising opportunities for outdoor activity



Fig.576 Sustainable transport strategy promotes cycling

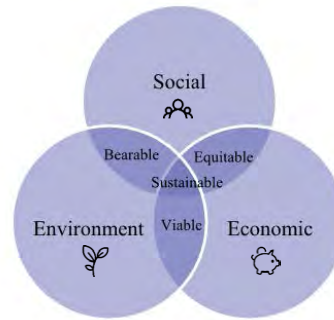

Fig.574 The three pillars of sustainability

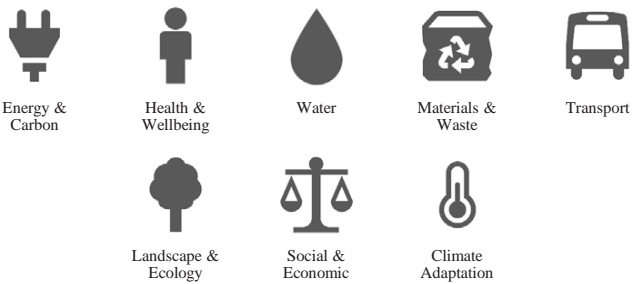

Fig.572 Best practice design across eight categories

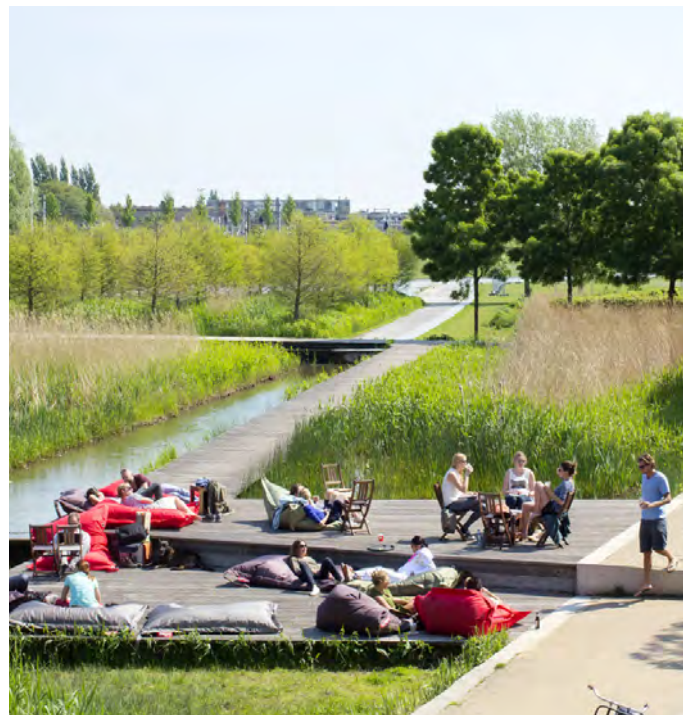

Fig.575 Sustainability drainage systems - proposed Central Park Swale character precedent

## 9.2 CLIMATE ADAPTATION

**For each Development Plot coming forward for a Reserved Matters Application, climate adaptation shall be considered.**

### 9.2.1 Climate Change Resilient Design

Measures to help mitigate future climate change scenarios have been included in the preceding guidance e.g. street tree framework.

Sustainable Urban Drainage Systems, designed for a changing climate, will be implemented within the development.

Additional measures to help future development adapt to future climate change are set out below:

#### Overheating:

A thermal analysis of the buildings will be required to support Reserved Matters Applications to demonstrate the resilience of the development and how the development can be adapted for a projected climate change environment. This should be based on projected increases in temperature due to climate change over the life-cycle of the development in accordance with the latest available climate change projections for the UK.

Shaded areas will be incorporated into the landscape to provide refuge and shelter.

#### Water stress:

An assessment of water stress should be considered in the context of climate change over the life-cycle of the development. Water-saving measures shall be maximised in each development proposal.

#### Flooding:

The development will incorporate mitigation measures to reduce the risk of localised flooding. Any flood risk analysis undertaken will include climate change considerations in accordance with the latest available climate change projections for the UK

#### Long-term management:

A Climate Change Adaptation plan should be produced, covering the design and management of the development. This should focus on building adaptive capacity into the design and avoiding adaptation constraining decisions.

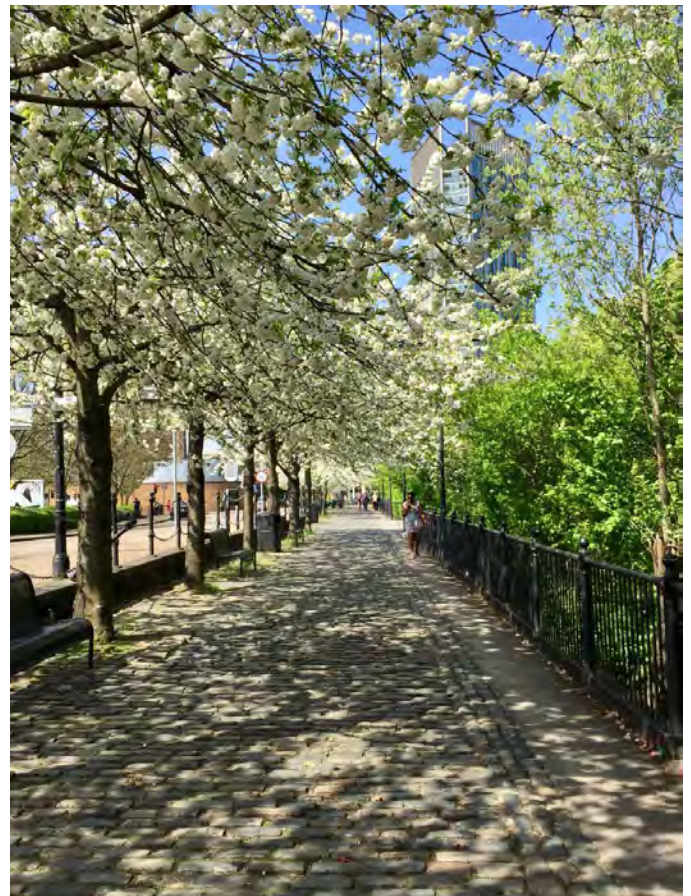

Fig.577 Precedent image of street trees used to provide shading



Seasonal warming



Drier summers



More wet months



More intense, short-periods



Less air frost and snowfall



More winter gales

Fig.578 Climate Adaptation

## 9.3 ENERGY AND CARBON

**The principles of the energy hierarchy will be considered and energy consumption will be minimised through the use of passive design principles and energy efficient systems.**

### 9.3.1 Carbon emissions

York Central aspires to be an exemplary scheme in terms of carbon emissions.

Where possible all Reserved Matters Applications should surpass the current CYC minimum standards by a minimum 10 percentage points.

Where practicable applicants are strongly encouraged to target net positive or zero carbon development.

PassivHaus certification is strongly encouraged. <http://www.passivhaustrust.org.uk/>

Where PassivHaus certification is not practicable, the incorporation of passive house design principles and standards is strongly encouraged.

### 9.3.2 Certification

There are a number of established standards which will help applicants to meet the requirements of the design guide and of the sustainable aspirations of York Central.

**All non residential buildings shall be certified BREEAM Excellent, or the equivalent standard, as a minimum**

Low or Zero Carbon (LZC) feasibility studies are strongly encouraged.

**All residential and non residential buildings shall be EPC A rated**

All residential buildings should consider the principles within the Building for Life Standards, or the current equivalent. Accreditation for all schemes is strongly encouraged.

### 9.3.3 Energy conservation

**External drying spaces shall be provided for all residential schemes.**

The inclusion of internal drying spaces is strongly encouraged. See Chapter 08 Building Typologies.

### 9.3.4 Energy efficiency

The inclusion of energy efficient technologies is strongly encouraged. This may include the use of Photo Voltaic (PV) panels.

### 9.3.5 Low carbon energy supply

The carbon intensity of energy supply that will generate power for the site must be considered as part of any scheme. If practicable, all energy should be generated from Low or Zero Carbon energy sources. It is strongly recommended that all schemes work towards this aim.

The use of photovoltaic cells shall be considered wherever possible for roofs, particularly higher level roofs, subject to the constraints described in Chapter 06 Appearance Site Wide.

### 9.3.6 Passive design

The massing and orientation of all buildings must be considered in terms of passive heating and cooling.

**Natural daylighting shall be optimised.**

**Daylight assessments must be performed for all Reserved Matters Applications with the exception of pavilion buildings.**

### 9.3.7 Embedded Carbon

Where practicable applicants are encouraged to consider the embedded carbon of the proposed development approach and to consider means to reduce this in the design of the development.



Fig.579 The Energy Hierarchy

## 9.4 HEALTH AND WELL BEING

Along with local facilities and open space, building environments - both internal and external - shall be designed to contribute to the health and wellbeing of residents and other building users. Good design shall maximise good daylighting, air quality, thermal and acoustic comfort, and biophilia.

### 9.4.1 Healthy environments

**Appropriate sound insulation shall be used. This shall be appropriate to the location on the site and address both internal and external noise sources.**

**Construction environmental impacts must be considered and mitigated.**

All schemes should target zero Volatile Organic Compounds (VOCs) used.

### 9.4.2 Outdoor environment

Development proposals shall encourage people to spend time outdoors where they may enjoy the physical and mental benefits of natural and green environments.

Such measures as outdoor wi-fi shall be considered.

### 9.4.3 Indoor environment

Views to the sky are strongly encouraged and should be optimised in the design of all buildings.

### 9.4.4 Air quality

The development will consider both internal and external air quality with the aim of contributing to improved air quality and minimised air pollution.

All schemes should allow for boosted ventilation rates where appropriate.

### 9.4.5 Biophilia

**Biophilia shall be a consideration of the design of all buildings.**

The use of green walls is encouraged in locations with suitable orientation.

The use of building materials with natural, textural qualities is encouraged - refer to Chapter 06 Appearance Site Wide.

### 9.4.6 Standards and evaluation

**Community spaces shall meet the requirements of the WELL Building Standard.**

Post occupancy evaluation is strongly encouraged for all buildings.



Fig.580 Planted wall to multi storey car park (Copenhagen)

## 9.5 MATERIALS AND WASTE

The construction industry is one of the largest material consumers and generators of waste. As a large brownfield site York Central contains various existing resources and materials.

### 9.5.1 Designing out waste

It is strongly encouraged that all schemes consider the inclusion of recycled materials giving particular preference to those found in or near to the site.

Modular and componentised design, and off-site construction are strongly encouraged alongside waste efficient procurement practices.

It is strongly encouraged that the design of all buildings allow for flexibility of use over time. **Multi storey car parks shall be designed to either allow for easy deconstruction or to be changed into a different use unless it can be strongly demonstrated that this is unfeasible.**

All schemes should minimise the consumption of non renewable resources.

The use of the 'ReSOLVE framework' and principles of 'circular economy' is strongly encouraged.

**Cut and fill shall be optimised.**

**Buildings shall be designed with deconstruction in mind. Ease of maintenance and replacement shall be considered.**

**Durability of materials shall be considered.**

**Leased materials shall be used where appropriate.**

### 9.5.2 Construction waste

**All projects must generate a Site Waste Management Plan.**

**Waste must be monitored.**

Material take back practices are strongly encouraged. All schemes should target zero waste to landfill.

### 9.5.3 Operational waste

Refer to Building Typologies for the management of waste.

### 9.5.4 Responsible sourcing

The social, ethical and environmental impacts of the sourcing and supply of raw materials will be considered as part of the material selection process.

### 9.5.5 Environmental impact

**All timber shall be FSC certified.**

All schemes should consider the design life cycle impact of any specified materials and components.

### 9.5.6 Refuse, recycling and reuse

All buildings shall be provided with appropriate refuse and recycling facilities according to current local policy. Provision for composting is strongly encouraged.



Fig.581 Materials and waste



Fig.582 Designing out waste

## 10 GLOSSARY



### **Above Ordnance Datum (AOD)**

Vertical datum used by the Ordnance Survey as the basis for deriving altitude. Building heights and Parameter Plan height limits are expressed in terms of AOD. Above Ordnance Datum, i.e. meaning a level above mean sea level.

### **Access**

The accessibility to and within the site, for vehicles, cycles and pedestrians in terms of the positioning and treatment of access and circulation routes and how these fit into the surrounding access network.

### **Accurate Visual Representation (AVR)**

An Accurate Visual Representation is a static or moving image that shows the location of a proposed development as accurately as possible to represent fairly the visual and spatial properties of that development.

An Accurate Visual Representation is typically a calibrated photomontage of the development overlaid upon a Verified View.

### **Active frontages**

Development frontage on the ground floor where inhabited residential or non residential uses are located, with a visually permeable elevation (e.g. windows or glazing) and a generous distribution of entrances.

### **Address**

The main entrance and primary facade for a building.

### **Amenity**

A positive element that contributes to the overall character or enjoyment of an area.

### **Ancillary building structures**

Secondary building elements that do not form part of the primary massing of the building. Examples include balconies and canopies.

### **Ancillary Development Zone**

A building frontage where balconies are permitted to project beyond the maximum building line.

### **Any Permitted Use**

Any use class as defined in the Development Specification.

### **Appearance**

The aspects of a building or place within the development which determine the visual impression the building or place makes, including the external built form of the development, its architecture, materials, decoration, lighting, colour and texture.

### **Application Site**

The application site largely comprises the 'teardrop' shaped site to the west of York Railway Station, bounded by the East Coast Main Line (ECML) to the north, Water End to the east and the Freight Avoiding Lines (FAL) to the south.

### **Basement**

Below ground building area.

### **Biophilia**

How the project incorporates nature, patterns and interaction with nature through environmental design and layout.

### **Block**

A building or set of continuous buildings within a plot.

### **Building exclusion zone**

An area where no built massing over 4m in height is permitted.

### **Building for Life 12**

Also known as 'BfL 12' is the industry standard for the design of new housing developments.



**Building height**

The height of a building measured AOD.

**Building line**

The predominant face of buildings that affects the enclosure of the public realm. On the building heights Parameter Plan, the building line is the control line which, when extruded vertically, forms the plane to which the majority of a building facade shall meet.

**Building typology**

An arrangement of building form and land-use that interfaces with the surrounding urban context or built environment in a particular way. Building typologies are not specific to an architectural style and can be expressed in multiple ways.

**BREEAM**

Building Research Establishment Environmental Assessment Method, a benchmark for appraising the sustainability of building design, construction and operation.

**Car sharing**

Two or more people travelling in one car as opposed to driving their own cars.

**Character**

The combination of Scale, Layout, Access, Use, Appearance, and Landscaping of streets, open spaces, and buildings that can give places their own distinct identity.

**Circular economy**

An alternative to a traditional linear economy (make, use, dispose) in which we keep resources in use for as long as possible, extract the maximum value from them whilst in use, then recover and regenerate products and materials at the end of each service life.

**Character Area**

Zones with a predominance of a particular 'Character'. Buildings and their surrounding landscaping are subject to the design guideline

chapter of the Character Area in which they sit. The Character Areas are:

Station Quarter (Development Zones B, C, D, E & F)

Foundry Quarter (Development Zones L, K, H, N & P)

York Yard South (Development Zones M & J)

A number of developments in a locality or a continuous activity over time that together may have an increased impact on the environment, local community or economy.

**CPTED**

Crime Prevention Through Environmental Design. It is a multi-disciplinary approach to deterring criminal behaviour through environmental design. CPTED strategies rely upon the ability to influence offender decisions that precede criminal acts by affecting the built, social and administrative environment.

**Cumulative Development Plan**

Plan that is a combination of the 'Illustrative Masterplan' and incorporates the latest Reserved Matters approvals.

**Curtilage Zone**

The land between the development zone edge and the exterior building facade at ground floor.

**Defensible space**

A place with a clear sense of ownership and responsibility to promote security and discourage antisocial behaviour.

**CYC**

City of York Council.

**Description of Development**

Refer to definition provided in the Development Specification.

**Developer**

A person or a company that either buys land and builds something on it or buys buildings and makes them more modern.

**DAS**

Design and Access Statement.

**Design Guide**

The 'Design Guide' sets out the guidelines for the Outline Proposals by which any 'Reserved Matters Applications' will need to follow if they are to be considered acceptable.

**Detailed Proposal**

Parts of the Masterplan submitted for detailed planning approval.

**Development Plots**

Development plots will be determined by ownership boundaries and are therefore not delineated within the Design Guide or York Central Parameter Plans. Each development zone may contain single or multiple development plots.

**Development Zone**

The allowable area of development which is defined by a maximum boundary. Each Development Zone is subject to maximum height restrictions, though these may vary within a Development Zone. Within a Development Zone there may be required routes or spaces, but the arrangement of these may be subject to agreed limits of deviation. Each component Development Zone is identified by a letter (e.g. 'Development Zone' A).

**Dual aspect**

A unit with windows on two walls facing two different directions.

**Easement**

A right benefiting a piece of land (known as the dominant land) that is enjoyed over another piece of land owned by someone else (the servient land).

**Enclosure**

The definition of the public realm through the use of building facades to create a space such as a street or a square.

**Environmental Impact Assessment (EIA)**

Environmental Impact Assessment. The assessment of the likely significant environmental effects of a development.

**Environmental Statement (ES)**

Report in which the process and results of an Environmental Impact Assessment are documented.

**Finished Floor Level (FFL)**

The height above Ordnance Datum (AOD) at which the ground floor of the buildings will be built.

**Flood Risk Assessment (FRA)**

The formal assessment of flood risk issues relating to the Proposed Development. The findings are presented in an appendix to the Environmental Statement.

**Floorplate**

The plan area of a building at a given floor level.

**Food and Beverage (F&B)**

Restaurants, cafés, and food outlets (use classes A3 and A4). The deployment of this use type often forms part of a strategy to provide active frontages.

**Footprint**

The area on a project site that is used by the building structure and is defined by the perimeter of the building plan. Parking lots, landscapes, and other nonbuilding facilities are not included in the building footprint.

**Framework Travel Plan**

A document that reflects the standard requirements for major developments, necessary part of the initial planning submission. Generally a Travel Plan is a long-term management strategy for integrating proposals for sustainable travel into the planning

process. The Framework Travel Plan is produced when the 'end users' or 'users' are not known and it will be used to devise subsequent individual plans for each element of the development.

### **Frontage**

The boundary between a plot of land or a building and the road or public realm onto which the plot or building fronts.

### **FSC**

Forest Stewardship Council.

### **Full Planning Application**

An application seeking complete approval of the proposal, including appearance, means of access, landscaping, layout and scale. A Full Planning Application will be submitted in due course for the delivery of infrastructure comprising a new access road and new rail spur to the National Railway Museum by City of York Council (CYC).

### **Ground level**

The floor of a building that is at or nearest to the level of the ground around the building.

### **Habitable rooms**

Any room used or intended to be used for sleeping or living in, and kitchens over 11 sqm. Enclosed spaces such as bath or toilet facilities, service rooms, corridors, laundries, hallways, utility rooms or similar spaces are excluded from this definition.

### **Hard/soft landscaping**

Hard landscaping is the provision of features such as paving, lighting, seating, etc. whilst soft landscaping is the provision of plants, shrubs and trees to improve the quality of the environment.

### **Heritage Asset**

A building, monument, site, place, area or landscape identified as having a degree of significance meriting consideration in planning

decisions, because of its heritage interest. 'Heritage Asset' includes designated heritage assets and assets identified by the local planning authority including local listing.

### **Historic England**

Historic England are the Government's statutory adviser on the historic environment and a consultee in the planning process.

### **Homes England**

Homes England are the Ministry of Housing, Communities & Local Government's non-departmental public body, responsible for increasing the number of new homes that are built in England. Homes England are a major landowner within the application site.

### **Illustrative material**

Non-prescriptive information provided as an example or explanation to support the Development.

### **Illustrative Masterplan**

A scheme which demonstrates one possible iteration of the Development within the 'Outline Parameters'.

### **Illustrative Plans**

Drawings that show the 'Indicative Scheme' which demonstrates one interpretation of the 'Specified Parameters'.

### **Inclusive design**

Designing the built environment, including buildings and their surrounding spaces, to ensure that they can be accessed and used by everyone.

### **Indicative Scheme**

The 'Indicative Scheme' demonstrates one interpretation of the "Specified Parameters".

### **Land Use**

The use of land and buildings as defined by 'use classes' in the Town and Country (Use Classes) Order 1987 (as amended).

### **Landscape Character Area (LCA)**

Areas of homogeneous landscape or townscape character. Typical components defining character include landform, land cover, settlement pattern, form and enclosure.

### **Landscaping**

The treatment of land (other than buildings) for the purpose of enhancing or protecting the amenities of the site and the area in which it is situated and includes: (a) screening by fences, walls or other means; (b) the planting of trees, hedges, shrubs or grass; (c) the formation of banks, terraces or other earthworks; (d) the laying out or provision of gardens, courts, squares, water features, sculpture or public art; and (e) the provision of other amenity features.

### **Layout**

The way in which buildings, routes and open spaces within the development are provided, situated and orientated in relation to each other and to buildings and spaces outside the development.

### **Lead Developer**

The developer who has overall responsibility for the oversight of the Masterplan and its delivery.

### **Limits of deviation**

The lateral limits shown on the Works Plan(s) and the vertical limits (upwards and downwards) submitted as part of the Application and within which the Proposed Development may occur.

### **Listed Building**

A building that has been placed upon the Statutory List of Buildings of Special Architectural or Historic Interest.

### **Local Development Framework**

The system of plan making introduced by the Planning and Compulsory Purchase Act 2004. It is a suite of local development documents produced by the local planning authority, which collectively form the spatial planning strategy for its area.

### **Local Nature Reserve**

A non-statutory site of local importance for wildlife, geology, education or public enjoyment.

### **Local Planning Authority**

The Local Planning Authority is responsible for the determination of planning applications. The LPA for this project is City of York Council.

### **Local Plan**

Local Plans provide a detailed framework of spatial and strategic policies against which applications can be assessed in a local planning authority area.

### **Local Wildlife Site (LWS)**

A non-statutory designation covering a discrete area of land which is considered to be of local significance for its wildlife features.

### **LZC**

Low and zero carbon technology. It's the term given to technologies that emit low levels of CO2 emissions or no net CO2 emissions.

### **MDE**

Maximum Developable Extents.

### **Microclimate**

The small scale modification of climate by a building or urban environment on a localised area, including temperature, wind, and overshadowing effects.

### **Mitigation measures**

A term used in EIA to describe measures proposed to prevent, reduce and, where possible, offset any significant adverse environmental impacts.

### **Mixed use**

Provision of a mix of complementary uses, such as residential, community and leisure uses, on a site or within a particular area.

**Multi storey car park (MSCP)**

A car parking facility comprised of more than one floor level, typically above ground.

**National Planning Policy Framework (NPPF)**

The National Planning Policy Framework which came into effect on 27 March 2012.

**National Railway Museum**

The National Railway Museum is part of the Science Museum Group, and a major land owner within York Central. The National Railway Museum comprises the Former North Eastern Railway Goods Station and the York North Engine Shed located north and south of Leeman Road within the application site.

**Network Rail**

Network Rail own, operate and develop Britain's railway infrastructure. Network Rail are a major land owner within the York Central site.

**Overlooking**

A term used to describe the effect when a development or building affords an outlook over adjoining land or property, often causing loss of privacy.

**Overshadowing**

The effect of a development or building on the amount of sunlight presently enjoyed by a neighbouring property or open space, resulting in a shadow being cast over that neighbouring property or open space.

**Outline Planning Application (OPA)**

Outline application for a mixed use redevelopment of the site to include new commercial and residential uses, the expansion of the National Railway Museum and a new Central Green Space for the York Central site.

**Parameter Plans**

One of the Control Documents. The Parameter Plans define the extent of the proposed routes,

open spaces and Development Zones across the site against a series of minimum or maximum dimensions. Together with the Development Specification they control the location of development to achieve the agreed layout, access, use and scale allowed within the Parameters.

**Parameters**

The parameters within which the Development is controlled. The 'Parameters' are set out in the three 'Development Control Documents'.

**Passive surveillance**

Design that increases the occupation and/or visibility of a space to deter crime.

**Permitted Uses**

Those uses which are permitted in York Central, as detailed in the Description of the Development and further detailed within the Development Specification.

**Phases**

Phasing is used to describe the order in which the development is likely to be delivered.

**Planning Application Area**

The Planning Application Boundary is shown as a redline on the Planning Application Boundary Drawing.

**Planning Permission**

The Planning Permission to be granted pursuant to the Planning Application authorising the carrying out of the Development, subject to the approval of Reserved Matters Application in relation to the Outline Proposals.

**Predominant Use**

The use which dominates by occupying the largest amount of floor area within the building.

**Private realm**

Privately owned space dedicated for use by its owners or occupants.

### **Proposed Development**

The development to which the Application relates.

### **Open space**

Publicly accessible outdoor space.

### **Public realm**

The space between and within buildings that is publicly accessible, including streets, squares, forecourts, parks and open spaces.

### **Reserved Matters**

A reserved matters application deals with some or all of the outstanding details of the outline application proposal including appearance, means of access, landscaping, layout and scale.

### **Reserved Matters Application (RMA)**

An application for the approval of Reserved Matters.

### **Residential use**

Use for a purpose falling within Use Classes C1, C2, C3, and C4 as defined by the Town and Country Planning (Use Classes) Order 1987 (as amended).

### **ReSOLVE framework**

A framework of principles for a circular economy developed by McKinsey.

### **Retail Use**

Use for a purpose falling within Use Classes A1, A3, A4 and A5 as defined by the Town and Country Planning (Use Classes) Order 1987 (as amended).

### **Right of Way**

A right to pass over land, which may be for the benefit of a particular landowner or the general public.

### **Roofscape**

The appearance of buildings as seen along the skyline.

### **Routes**

An uncovered trafficable area open to the sky, and a general term for the linking space between plots. It is non specific to the type of traffic it will carry.

### **Scale**

The height, width and length of each building proposed within the development in relation to its surroundings.

### **Secured by Design**

The national police scheme which aims to minimise crime and opportunities to commit crime through better design of buildings and places.

### **Servicing**

Access strategy for infrastructural and waste services.

### **Setbacks**

Where the frontage of a building is not extended to the limits of the building line.

### **Single-aspect**

A unit with windows on one wall only facing a single direction.

### **Sustainable Urban Drainage System (SUDS)**

Surface water drainage methods that take account of quantity, quality and amenity issues.

### **Swing use**

Interchangeable uses within a Development Zone detailed in the Development Specification.

### **S106 Agreement**

An agreement between a developer and local authority under Section 106 of the Town and Country Planning Act 1990 (as amended) attached to a planning permission to make development acceptable that would otherwise be unacceptable in planning terms.

### **Sq m**

Square metres.

### **Specified Parameters**

The 'Proposed Development' is defined by 'Specified Parameters'. The 'Environmental Statement for the Outline Planning Application' assesses the "Specified Parameters".

### **The Masterplan**

The Masterplan includes 10 Development Zones and the public realm between, within the red line boundary. It comprises 19.2 ha and will allow for a varying quantum of uses.

The Masterplan is referred to throughout the application documents as the 'Development' although these terms can be used interchangeably.

### **The Development**

The Development consisting of the Outline Proposals and the Detailed Proposals.

### **The Site**

The area defined by the York Central planning application boundary.

### **Sustainability Statement**

A report that demonstrate how a scheme will address local "core policies" set by a Council.

### **Townscape**

Townscape is the visual appearance of a town or urban area; an urban landscape.

### **Townscape views**

Selected views that show how the scheme appears in the city and in relation to the main existing buildings. Usually the townscape views are taken from particular places of the city from which the resultant views are evocative or interesting.

### **Townscape Visual Impact Assessment (TVIA)**

A qualitative assessment of the significance of change in the character of a townscape potentially caused by a development proposal. TVIAs are to be conducted by suitably qualified members of a relevant professional body.

### **Traffic Impact Assessment (TIA)**

A study which assesses the traffic and safety implications relating to a specific development, whether the surrounding road network will be able to support additional traffic while maintaining an acceptable level of service.

### **Transport Assessment**

A comprehensive and systematic process that sets out various transport issues relating to the proposed development. It identifies what measures will be taken to deal with the anticipated transport impacts of the scheme in relation to all forms of travel.

### **Upper floor**

Any floor located above ground and upper ground (or mezzanine) floor.

### **Urban grain**

The combined pattern of blocks and streets, taking into account the character of street blocks and building height and size and how that all work together in an interrelated manner to create and enable movement across.

### **Use Class**

References to use classes refer to the use classes as set out in the Town and Country Planning (Use Classes) Order 1987 (as amended).

### **Verified View**

A Verified View is a photographic image calibrated by survey and verifiable photographic methodology so that it may be used within an Accurate Visual Representation of a development.

## 11 IMAGE CREDITS

















ARUP

**Allies and Morrison**

Gustafson  
Porter +  
Bowman